

Ultrasonic Occupancy Detection System

OCC/U Ultrasonic Occupancy Detection System



Description

The ceiling mounted OCC/U Ultrasonic Occupancy Detection System is specifically designed for lighting control in open plan office environments. Several options are available to suit all user needs.

Designed for both office and walkway type applications, the ultrasonic detector heads detect movement, even the small movements of people seated at desks, and switch lighting accordingly via an IQ Controller for combined HVAC and lighting control. Up to 10 detectors can be connected to a single IQ controller input to control larger areas. The two types of detector head fit into a ceiling tile using a standard sinking box or mounting kit.

Features

- Monitors occupancy over approximately 5 m diameter floor space.
- Fully automatic system operation.
- Direct connection to IQ Controllers.
- Lights never go off when needed (even detects hand movements).
- Simple low cost installation.
- Extendable coverage of up to 10 detectors per IQ input.
- Corridor linking facility.

Physical

OCC/UDA

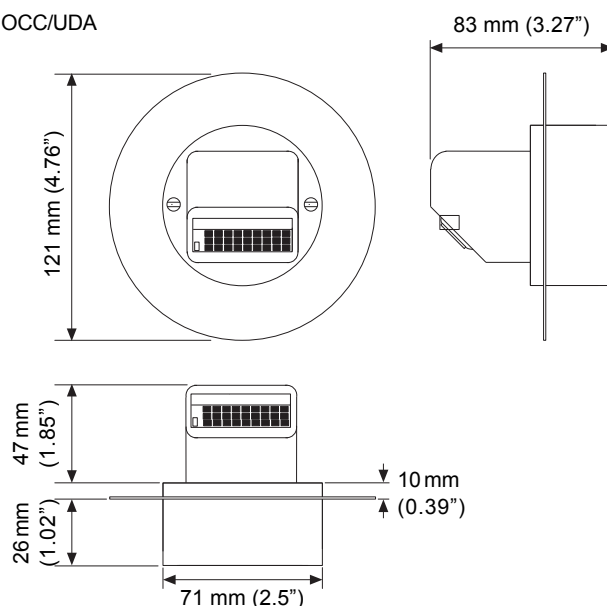

OCC/UD

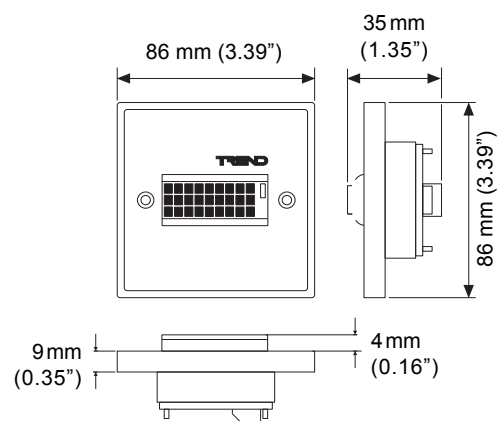

FUNCTIONALITY

The OCC/U Ultrasonic Occupancy Detection System can be supplied with one of two different ultrasonic detectors. Movement is detected by the ultrasonic detector which passes a signal to an IQ Controller. This signal is then used to switch the lighting (and/or HVAC).

The OCC/U connects directly to an IQ Controller from which it takes its power. It can use a digital input channel or voltage input channel. The OCC/UD/DC is adjustable in one direction and the OCC/UDA/DC is adjustable in two directions to ensure that the correct area is monitored. If required, up to ten detectors can be connected in parallel to a single voltage, or digital input channel of an IQ controller. Each detector requires 25 mA at 24 Vdc so the maximum number of detectors is limited by the total current available. When any one detector detects a movement the input will change status. This enables the lighting for a large area to be controlled by a single IQ controller input. For fast initial response the control strategy must be connected to a digital input and fast sequenced.

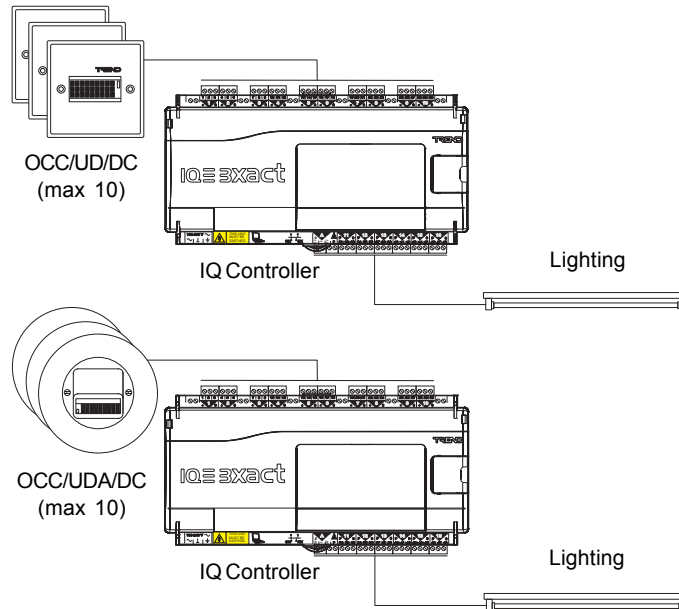

Detection Pattern

The ultrasonic detectors use ultrasound to monitor a space for movement. This involves transmitting an ultrasound signal and examining the reflected signal for frequency variations. The diagram below indicates the detection pattern for the different types of movement.

The range of the signal depends on the type of area being monitored, and the type of movement being observed. Hence walking activity can be observed at a greater distance than a slight hand movement.

Note, however that detectors are only tested to a range of 7.5 m (8.2 yds).

Detection pattern OCC/UDA Ultrasonic Detectors at 2.4 m (2.6 yds)

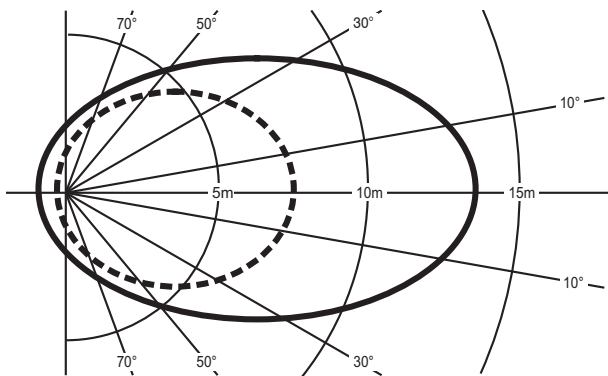

Detection pattern for walking activity

Detection pattern for sedate activity

Detection pattern OCC/UD Ultrasonic Detectors at 2.4 m (2.6 yds)

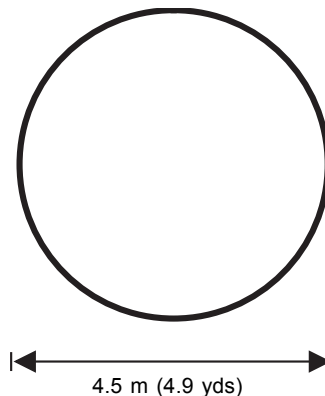

Detection pattern

Corridor Linking Facility

It is often desirable to provide some general lighting in a notional corridor, so that if any ultrasonic detector senses movement in the corridor, all the lights in the corridor will be turned on. This is achieved by simply connecting up to 10 detectors in parallel to an IQ input channel.

Commissioning the Sensor

The sensor head can be rotated to cover required detection area (UD 30° vertical plane, UDA 80° vertical plane, 180° horizontal plane).

The sensors have an adjustment screw that allows the range to be increased or decreased (clockwise reduces the range).

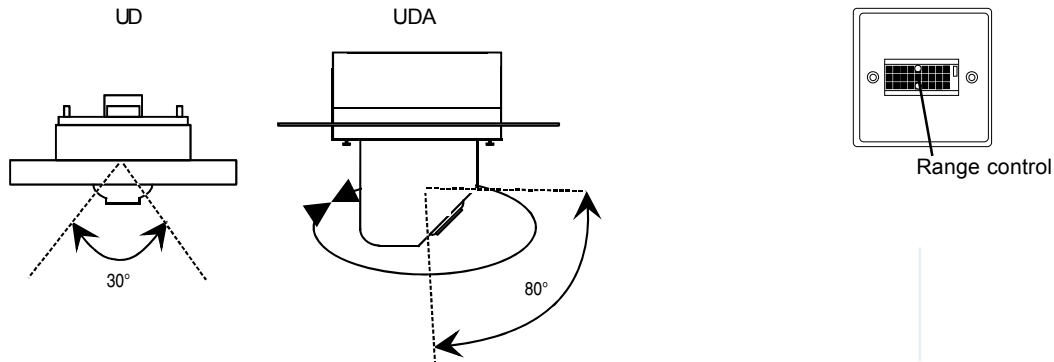

INSTALLATION

The detectors are mounted in a ceiling tile at a height of 2.4 to 3 m (2.6 to 3.25 yds) using a standard 1 gang mounting box, or 25 mm (0.98") switch sinking box. Screened 3 core cable must be used.

The procedure for installation is:
 mount the detectors, and IQ Controller
 wire the separate units together and to the IQ controller
 set up IQ controller sensor scaling and strategy
 apply power
 commission detector
 For full details see the OCC/U Installation Instructions (TG101684)

CONNECTIONS

Note that it is important to set the IQ Controller's input to digital, see the appropriate controller data sheet for details.

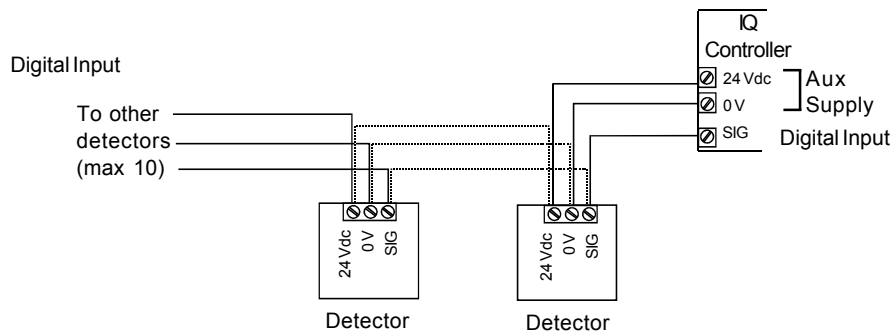

DISPOSAL



WEEE Directive :

At the end of their useful life the packaging and product should be disposed of by a suitable recycling centre.

Do not dispose of with normal household waste.

Do not burn.

ORDER CODES

OCC/[Item]

[Item]	Description
UD/DC	Ultrasonic detector, adjustable in 1 direction, connects to IQ input, requires 24Vdc
UDA/DC	Ultrasonic detector, adjustable in 2 directions connects to IQ input, requires 24Vdc.

SPECIFICATIONS

Electrical

Power required	:24 Vdc max (from IQ).
Power consumption	:25 mA
Frequency	:40 kHz ultrasonic
Detection signal	:0 to 14 Vdc (0 V = occupied, 14 V = non-occupied).
Detection Pattern	:See diagrams on page 3
Max distance between detector and IQ	:30 m (33 yds)

Mechanical

Dimensions	
/UD/DC	:86 mm x 86 mm x 35 mm (3.39" x 3.39" x 1.35")
/UDA/DC	:71 mm x 71 mm x 83 mm with 121 mm (2.5" x 2.5" x 3.27", 4.76") dia. ring
Weight	
/UD/DC	:85 g (3 ozs)
/UDA/DC	:100 g (3.5 ozs)
Mounting	
/UD/DC	:Standard sinking box
/UDA/DC	:Standard mounting kit
Skew	:± 15° lateral on detector barrel.

Environmental

Ambient limits	:-10 to +50 °C (14 °F to +177 °F), 0 to 80 % RH non-condensing
Protection	:IP20

Please send any comments about this or any other Trend technical publication to techpubs@trendcontrols.com

© 2009 Honeywell Technologies Sàrl, ECC Division. All rights reserved. Manufactured for and on behalf of the Environmental and Combustion Controls Division of Honeywell Technologies Sàrl, Z.A. La Pièce, 16, 1180 Rolle, Switzerland by its Authorized Representative.

Trend Control Systems Limited reserves the right to revise this publication from time to time and make changes to the content hereof without obligation to notify any person of such revisions or changes.

Trend Control Systems Limited

P.O. Box 34, Horsham, West Sussex, RH12 2YF, UK. Tel:+44 (0)1403 211888 Fax:+44 (0)1403 241608 www.trendcontrols.com

Trend Control Systems USA

6670 185th Avenue NE, Redmond, Washington 98052, USA. Tel: (425)897-3900, Fax: (425)869-8445 www.trendcontrols.com