

Duct Humidity and Temperature Sensors

Duct Humidity and Temperature Sensors



Description

Duct mounted relative humidity and temperature sensors for HVAC applications. The certified 2% high accuracy (1/2%) and standard 3% versions offer excellent linearity and stability over a wide humidity range (10 to 90 %RH).

Features

- Precalibrated for ease of commissioning
- IP65
- Operates over 0 to 100 %RH non-condensing
- ± 2% and 3% accuracy versions
- 2 part connectors for ease of installation
- Humidity sensor element protected by replaceable filter
- Capacitive humidity sensing element provides excellent long term stability
- Adjustable depth duct mounting flange option

Physical

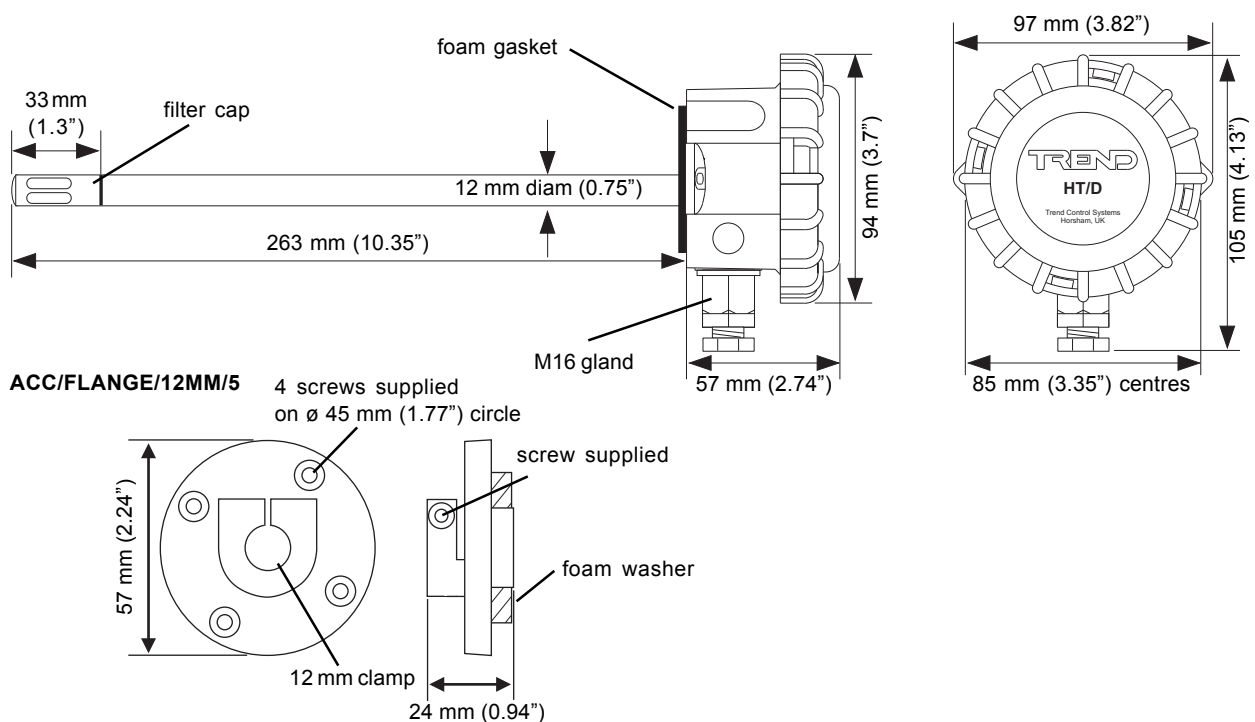

FUNCTIONALITY

The HT/D humidity and temperature sensors can be used for a wide range of HVAC applications, operating over a 0 to 100 %RH (non-condensing) range. They use a capacitive sensing element which exhibits excellent long term stability and linearity. The HT/D sensor offers 3% humidity measurement accuracy over a 10 to 90 %RH range while the HT/D/2% sensor offers 2% accuracy over 0 to 90 %RH, and 3% over 90 to 100 %RH. Both sensors provide a 4 to 20 mA transmitter output (corresponding to 0 to 100 %RH).

The HT/D/2% version incorporates a platinum resistance temperature (PRT) sensor with a 4 to 20 mA transmitter output (corresponding to 0 to +40 °C), whereas the standard HT/D version incorporates a directly connected thermistor temperature sensor.

CALIBRATION

The humidity sensing part of the HT/D sensor may be manually calibrated by the user. This involves keeping the sensor and the humidity reference chamber in the same room for at least 4 hours prior to the calibration.

The humidity chamber should be thoroughly cleaned before use.

The humidity sensing probe should be placed in the humidity chamber at least 30 mins prior to the calibration.

A dirty filter cap should be replaced prior to calibration.

During calibration the temperature must be kept constant.

The sensor may be calibrated in two ways:

One point humidity calibration: This is quick and simple. It should be used when the working range is limited to a narrow range around the nominal humidity point. This form of calibration decreases accuracy over remainder of working range.

Two point humidity calibration: This should be used for accurate adjustment over the whole working range of the sensor, or for calibration if the sensor has been replaced. The sensor is calibrated, first at the bottom of the humidity range, and then at the top of the humidity range. The difference between the levels should be greater than 30 %RH.

The calibration is performed by using the 2 pushbuttons on the rear of the sensor pcb. The calibration LED will illuminate while the calibration is in progress. The procedure is described in the HT/D Installation Instructions TG200988.

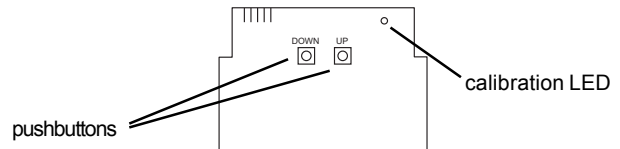

The calibration chamber and calibration liquids will need to be purchased from a specialist calibration equipment supplier.

INSTALLATION

Choose an accessible location where the sensor element will lie in the airstream to be measured.

Ensure that there is no stratification in the airstream being measured (i.e. downstream of mixing dampers, heating coils, cooling coils).

Mount the probe in the duct either by screwing the sensor box directly onto the duct, or by using the optional duct mounting flange.

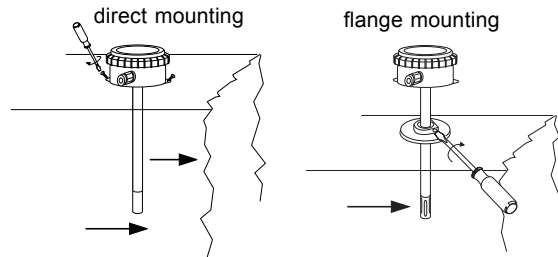

The probe requires a 15 mm (0.59") hole cut into the duct.

The sensor box may be screwed directly to the duct using 2 screws at 85 mm (3.35") centres.

The optional mounting flange is screwed to the duct using 4 off screws (provided) at 45 mm (1.77") centres.

The optional mounting flange enables the probe depth to be adjusted by tightening the flange clamp to secure the position.

Supply Voltage: The minimum supply voltage is 15 V when used with an IQ controller; if used with another device, the minimum voltage should be calculated from the equation:

$$\text{minimum voltage} = 10 + 0.02 \times R_{in} \text{ (where } R_{in} \text{ is input resistance)}$$

e.g. if $R_{in} = 500 \text{ ohms}$

$$\text{minimum voltage} = 10 + 0.02 \times 500 = 10 + 10 = 20 \text{ V}$$

The installation involves:

- Choose location
- Remove sensor lid
- Feed IQ cable through gland
- Wire cables
- Replace sensor lid
- Drill sensor probe hole
- Drill fixing holes
- Mount optional mounting flange if required

- Mount sensor on prepared location
- Set up IQ channels for current (I) (HT/D, and HT/D/2% humidity, and HT/D/2% temperature) or thermistor (T) (HT/D temperature)
- Configure IQ sensor modules
- Test sensor

Full installation details are given in the HT/D/... Installation Instructions, TG200988.

CONNECTIONS

HT/D

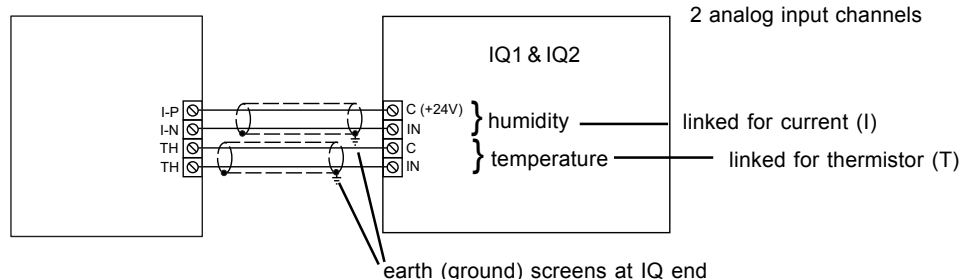

CONNECTIONS (continued)

HT/D (continued)

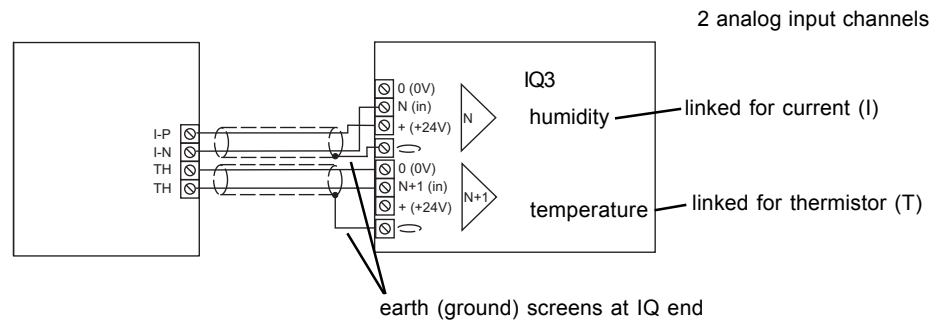

HT/D/2%

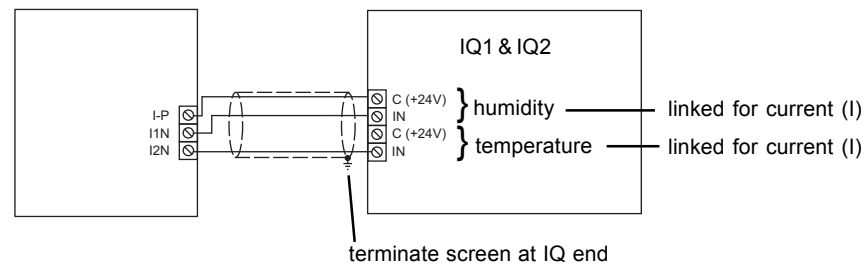

Note that when connecting to IQ3, in order to provide sufficient supply current to the sensor, the sensor I-P terminal must be connected to **both** channels' 24 V terminals.

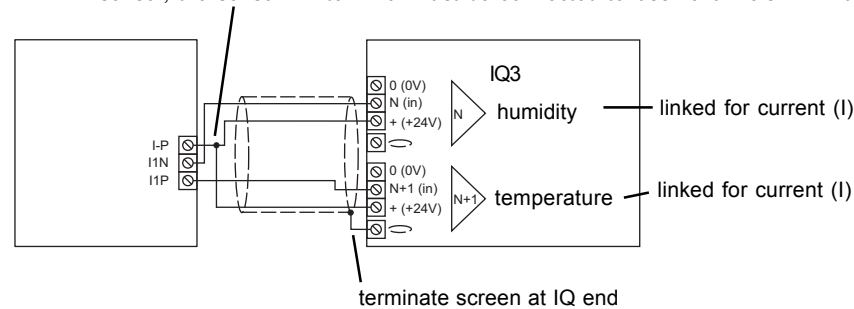

FIELD MAINTENANCE

The removal of dust, accuracy checking, and calibration is covered in the HT/D installation instructions. The accuracy of the sensor should be checked annually. If the sensor falls outside the quoted accuracy replace the filter and recalibrate.

Caution: Ammonia should not be used to clean the duct as it may affect the sensor.

PRODUCT CODES

- HT/D/2% :Duct humidity and PRT temperature sensor with $\pm 2\%$ humidity accuracy over 0 to 90 %RH and calibration certificate
- HT/D :Duct humidity and thermistor temperature sensor, $\pm 3\%$ humidity accuracy over 10 to 90 %RH
- ACC/FLANGE/12MM/5 :Optional, adjustable depth, duct mounting flange - pack of 5
- ACC/HTD/FILTER :Replacement PTFE membrane filter for duct sensor - pack of 5

DISPOSAL

WEEE Directive :



At the end of their useful life the packaging and product should be disposed of by a suitable recycling centre.
Do not dispose of with normal household waste.
Do not burn.

SPECIFICATIONS

Electrical

Humidity

Humidity operating range :0 to 100 %RH non-condensing
 Humidity element :Capacitive RH element
 Linearity :(0 to 98 %RH) less than ±1.5 %RH
 Stability :(20 to 30 °C, 68 to 86 °F, 20 to 80 %RH) drift < 1%/year
 Humidity accuracy :of sensor (at 23 °C, 73.5 °F, and 24 Vdc supply)
 HT/D :±3 %RH (10 to 90 %RH)
 HT/D/2% :±2 %RH (0 to 90 %RH), ±3 %RH (90 to 100 %RH)

Temperature dependence probe :typically 0.03%RH/°C (0.02%RH/°F)
 electronics :typically 0.03%RH/°C (0.02%RH/°F)
 Hysteresis :(10% to 80% to 10%) typically 1.7 %RH
 Resolution :0.05%RH
 Response time :(at 23 °C, 73.5 °F) t₉₀ less than 15 s
 Load resistance :Less than 500 Ω
 Humidity output signal :4 to 20 mA for 0 to 100 %RH

Temperature

Temperature measurement range :0 to +40 °C, 32 to 104 °F (recommended)
 Temperature element HT/D :Thermistor 10 kΩ at 25 °C
 HT/D/2% :Pt1000 (tolerance class A, DIN EN60751)
 Temperature accuracy:of sensor HT/D :(0 to +40 °C, 32 to 104 °F) ±0.5 °C, ±0.9 °F
 HT/D/2% :(at 23 °C, 73.5 °F) ±0.2 °C, ±0.36 °F
 Temperature output signal HT/D :Thermistor 10 kΩ at 25 °C (77 °F)
 HT/D/2% :4 to 20 mA for 0 to +40 °C (32 to 104 °F)
 Supply Voltage :15* to 30 Vdc
 * see calculation on page 2 if connected to a non-IQ device

Input channels and sensor scaling

The IQ controller's input channels must be set up correctly as described below, and the sensor type modules must be set up with the correct scaling. It is recommended to use SET (software tool) for the setting of sensor type modules. For all IQ2 series controllers with firmware of version 2.1 or greater, or IQ3 series controllers, the SET Unique Sensor References should be used.

If not using SET, use the appropriate manual settings and tables described below for all IQ2 series controllers with firmware version 2.1 or greater or IQ3; for all other IQ controllers see the Sensor Scaling Reference Card TB100521A.

Humidity

For both HT/D versions, link input channel for current, I.
 SET Unique Sensor Reference: **Humidity I**
 Manual setting: Use sensor type *scaling mode 5, characterise, with the input type set to 2 (current, mA) and the table below:

System Accuracy (including controller) :same as humidity accuracy of sensor

Y	Input type	2 (curr mA)
*E	Exponent	3
U	Upper	100
L	Lower	0
P	Points	2
x	ix	Ox
1	4	0
2	20	100

Temperature HT/D/2%
 Link input channel for current, I.
 SET Unique Sensor References:

PRTI 0+40 (°C)
PRTI +32+104 F (°F)

Manual setting: Use sensor type *scaling mode 5, characterise, with the input type set to 2 (current, mA) and the table below:

Units		°C	°F
Y	Input type	2 (current)	
*E	Exponent	3	
U	Upper	40	104
L	Lower	0	32
P	Points	2	
x	ix	Ox	
1	4	0	32
2	20	40	104

System Accuracy (including controller) :same as temperature accuracy of sensor

HT/D

Link input channel for thermistor, T.
 SET Unique Sensor References:

Thermistor HTST DT (°C)
Thermistor HTST DT F (°F)

Manual setting: use sensor type *scaling mode 5, characterise, with the input type set to 1 (thermistor volts, V) as in the table below.

Units		°C	°F
Y	Input type	1 (thermistor volts)	
*E	Exponent	3	
U	Upper	50	122
L	Lower	-5	23
P	Points	6	
x	ix	Ox (°C)	Ox (°F)
1	2.641	50	122
2	3.47	40	104
3	4.46	30	86
4	6.663	10	50
5	7.668	0	32
6	8.102	-5	23

System Accuracy (including controller) :±0.9 °C, ±1.62 °F (0 to +40 °C, 32 to 104 °F)

*Note that for IQ3 the scaling mode and exponent (E) don't need to be set up.

Mechanical

Dimensions

Duct probe :263 mm, 10.35" (including filter) x 12 mm, 0.75" (diameter)
 Head :105 mm (4.13") x 57 mm (2.24") x 97 mm (3.82")
 Fixing centres :85 mm ((3.35"))

Cable entry

:M20 conduit entry with M16 cable gland

Material

Enclosure :Impact resistant ABS
 Probe :Polycarbonate (flammability HB)
 Gasket :Closed cell neoprene (CR) foam rubber
 Filter :PTFE membrane filter
 Duct mounting flange:polycarbonate (flammability HB)

Connectors

:2 part rising cage clamp screw terminals for 0.2 to 1.5 mm², 16 to 24 AWG cable.

Weight

:200 gm, 7 oz approximately

Environmental

CE Compatibility :EN61000-6-2, EN61000-6-3

Working ambient limits

probe temperature :-20 °C (-4 °F) to +60 °C (140 °F)
 electronics temperature :-5 °C (23 °F) to +50 °C (122 °F)
 humidity :0 to 100 %RH non-condensing
 Storage temperature :-25 °C (-13 °F) to +60 °C (140°F)
 Protection (housing) :IP65

Please send any comments about this or any other Trend technical publication to techpubs@trendcontrols.com

© 2009 Honeywell Technologies Sàrl, ECC Division. All rights reserved. Manufactured for and on behalf of the Environmental and Combustion Controls Division of Honeywell Technologies Sàrl, Z.A. La Pièce, 16, 1180 Rolle, Switzerland by its Authorized Representative, Trend Control Systems Limited.

Trend Control Systems Limited reserves the right to revise this publication from time to time and make changes to the content hereof without obligation to notify any person of such revisions or changes.

Trend Control Systems Limited

P.O. Box 34, Horsham, West Sussex, RH12 2YF, UK. Tel:+44 (0)1403 211888 Fax:+44 (0)1403 241608 www.trendcontrols.com

Trend Control Systems USA

6670 185th Avenue NE, Redmond, Washington 98052, USA. Tel: (425)897-3900, Fax: (425)869-8445 www.trendcontrols.com