

TERMINATOR ROOF FANS

STYLISH, LOW PROFILE ROOF FAN
WITH A WIDE DUTY RANGE.

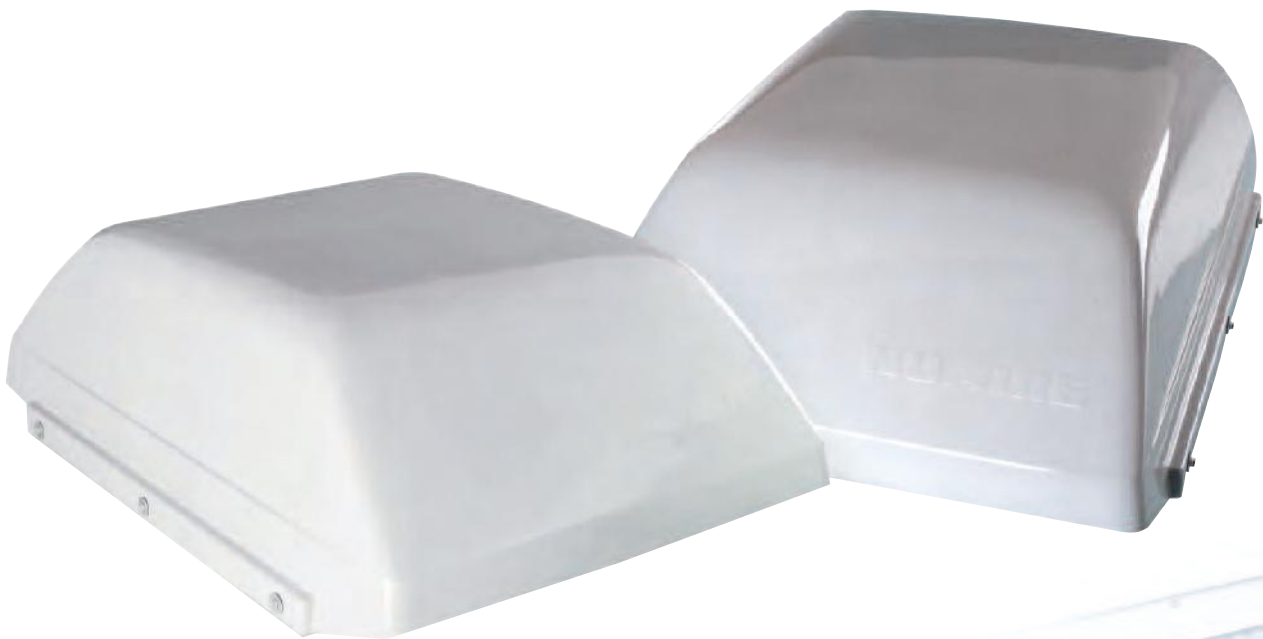

BENEFITS

UNOBTUSIVE DESIGN

Extremely rigid ultra low profile GRP cowl easily accommodated on all building profiles – cowl is also UV resistant.

ANY ROOF PROFILE

Soaker sheets and flashing plates are available to cater for all roof profiles.

ENERGY EFFICIENT

All 3 phase models are compatible with Ecosmart controls providing the most energy efficient cost effective solution.

QUIETER SYSTEM

Widest range of impeller types together with matching silencers provide the perfect acoustic solution.

SYSTEM CONTROL

Ecosmart compatibility allows other fans/ AHU's to interface directly with the Terminator. (3 phase only).

AVOIDS HEAT LOSS

Integrated backdraught shutters, limits heat loss from building when unit is off. Motorised dampers are optional.

FLEXIBLE INSTALLATION

The cowl can be wall mounted vertically for exposed weather location.

PERFORMANCE OPTIONS

Axial, mixed flow or centrifugal impeller options cater for all your systems particular pressure and sound requirements.

COLOUR MATCH

Standard cowl colour is goose wing grey (BS 00A05), (although any BS or RAL colour can be supplied).

ANCILLARIES

Full range of attenuators, mounting curbs, wall plates, etc. are available to complete your installation.

WARRANTY

Terminator has a 3 year warranty.
 Ecosmart Terminator has a 5 year warranty.

FAN OPTIONS

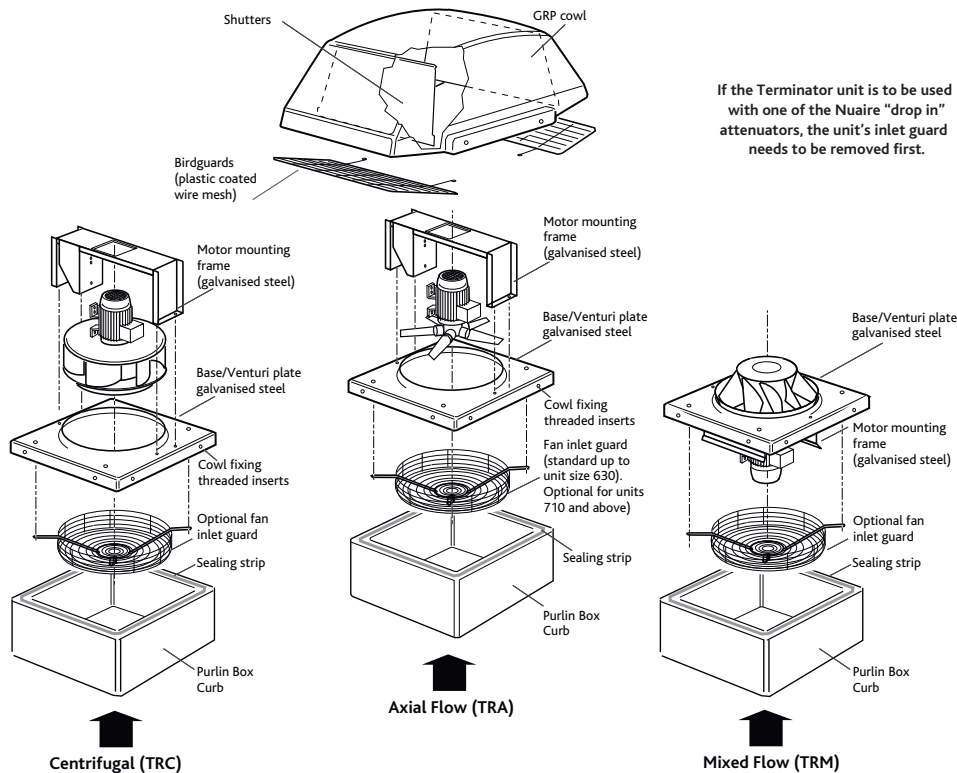

If the Terminator unit is to be used with one of the Nuaire "drop in" attenuators, the unit's inlet guard needs to be removed first.

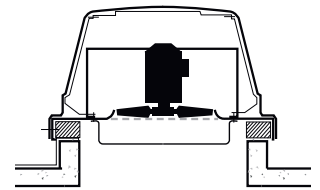

Axial Fan Code TRA.

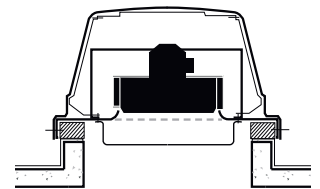

Centrifugal Fan Code TRC.

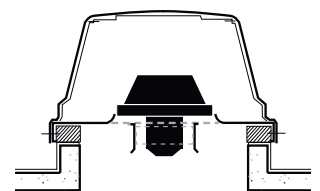

Mixed Flow Fan Code TRM.

PERFORMANCE - TERMINATOR ROOF EXTRACT FANS

Terminator TRA Axial Flow Units 1 - 15

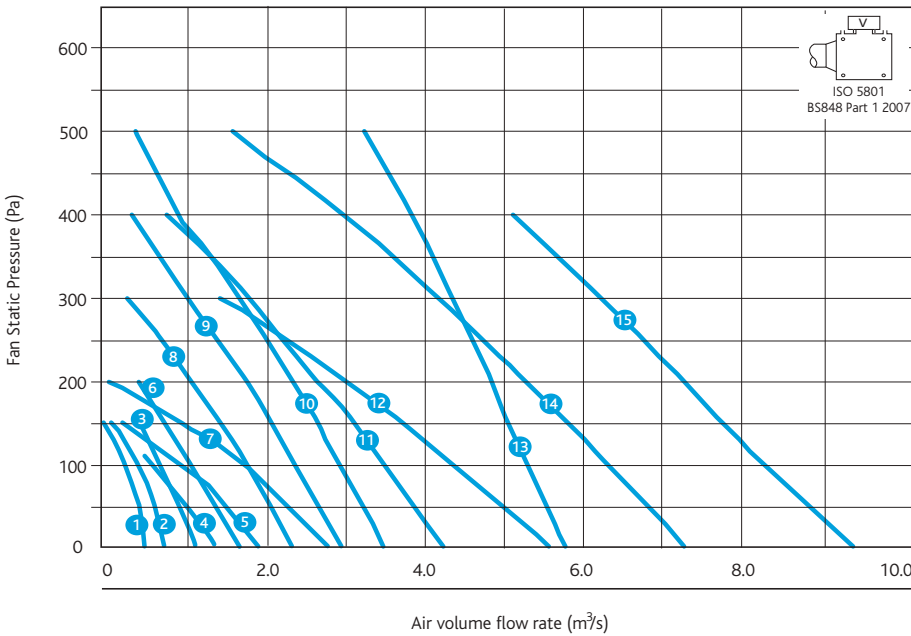

Casing

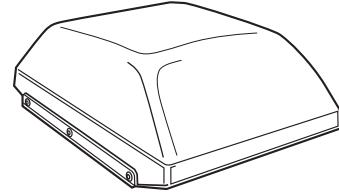

Code descriptions

TRAS 315 -4 1

1 | 2 | 3 | 4 | 5 | 6

1. Range code
2. Impeller
A = Axial
M = Mixed Flow
C = Centrifugal
3. Shutter
4. Fan size
5. Number of poles
6. Phase:
1 = Single phase,
3 = Three phase

Terminator TRM Mixed Flow 16 - 20

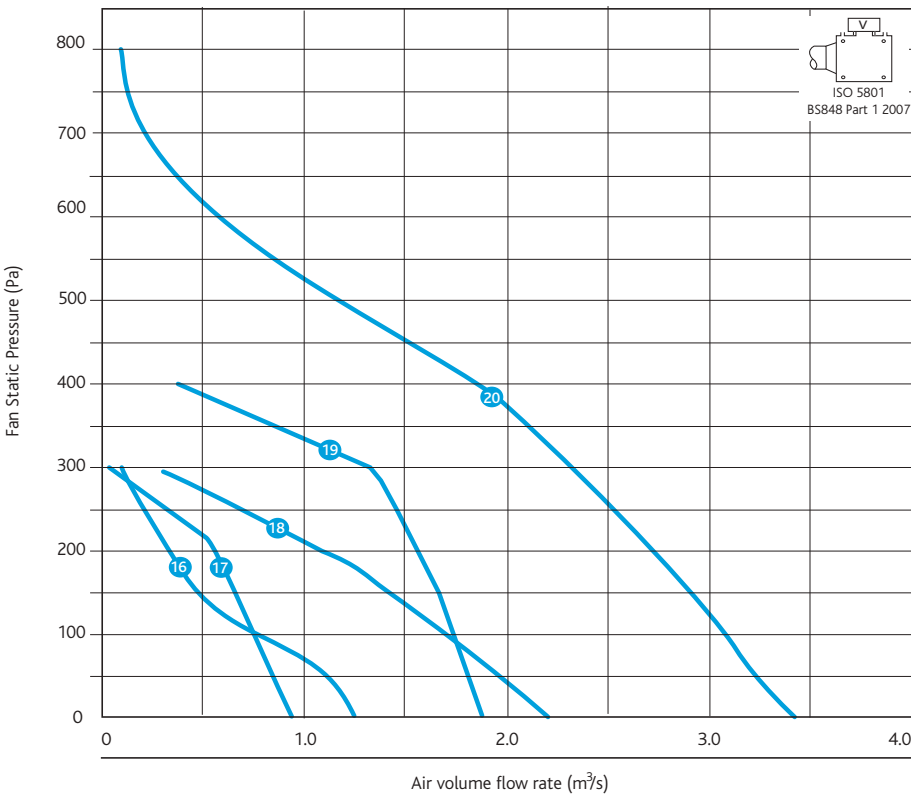

Control descriptions

(ES) (B) (C)

1 | 2 | 3

1. ES = Full Ecosmart controls – BMS interfaces and commissioning.
Controls (as 2 & 3 below) full compatibility with Ecosmart sensors.
2. B = BMS interfaces 0-10V, volt free run and fail indication.
Commissioning/speed control built in.
Adjustable trickle and boost if required
3. C = Commissioning/speed control built in.
Adjustable trickle and boost if required.
All the above control options are pre-programmed with a soft start function.
The above control options are provided in a purpose made module, mounted remote from the unit.
Other controls to be specified separately see selection table.

PERFORMANCE - TERMINATOR ROOF EXTRACT FANS

ELECTRICAL & SOUND AXIAL IMPELLER TRA

Curve	Code	Cowl		RPM	Motor				Induct inlet Open inlet Open outlet	Sound Power Levels (dB re 10 -12W) Octave band mid frequency (Hz)						Open inlet/ outlet dBA@ 3m	
		Size	Phase		Power (kW)	FLC (amps)	SC (amps)	SC ★/▲		125	250	500	1K	2K	4K		8K
1	TRAS315-41	A	1	1300	0.12	1.1	2.9	-	induct inlet	74	72	64	61	63	60	48	
									open inlet	68	69	63	61	63	60	48	51
									open outlet	68	72	66	64	67	64	52	54
2	TRAS350-41	A	1	1300	0.09	0.85	1.45	-	induct inlet	72	73	68	63	63	58	47	
									open inlet	66	70	67	62	63	58	47	52
									open outlet	66	73	70	65	67	62	51	55
3	TRAS400-41	B	1	1325	0.25	2.1	3.6	-	induct inlet	86	75	70	66	68	67	59	
									open inlet	80	73	69	66	68	67	59	57
									open outlet	80	76	72	69	72	71	63	60
4	TRAS500-61	C	1	860	0.18	1.55	3.5	-	induct inlet	72	73	66	70	68	66	57	
									open inlet	69	72	66	70	68	66	57	56
									open outlet	69	75	69	73	72	70	61	60
5	TRAS560-61	C	1	860	0.25	2.1	5	-	induct inlet	80	74	68	71	70	68	59	
									open inlet	76	73	68	71	70	68	59	58
									open outlet	76	76	71	74	74	72	63	61
6	TRAS450-41	B	1	1325	0.37	2.8	11.2	-	induct inlet	82	79	77	72	73	71	62	
									open inlet	77	77	76	71	73	71	62	61
									open outlet	77	80	79	74	77	75	66	65
7	TRAS630-61	D	1	835	0.55	5.4	14.8	-	induct inlet	94	86	84	85	84	80	71	
									open inlet	92	85	84	85	84	80	71	72
									open outlet	92	88	87	88	88	84	75	75
8	TRAS500-41	C	1	1335	0.55	3.6	10.8	-	induct inlet	80	81	74	77	76	74	65	
									open inlet	77	80	74	77	76	74	65	64
									open outlet	77	83	77	80	80	78	69	67
9	TRAS560-41	C	1	1335	0.94	3.6	14	-	induct inlet	87	82	76	79	77	76	67	
									open inlet	84	80	75	78	77	76	67	66
									open outlet	84	83	78	81	81	80	71	69
9	TRAS560-43	C	3	1335	0.75	2.3	8.7	-	induct inlet	87	82	76	79	77	76	67	
									open inlet	84	80	75	78	77	76	67	66
									open outlet	84	83	78	81	81	80	71	69
10	TRAS630-43	D	3	1320	1.5	4.4	17.7	-	induct inlet	86	79	76	78	76	72	63	
									open inlet	84	78	76	78	76	72	63	64
									open outlet	84	81	79	81	80	76	67	68
11	TRAS80L-43	E	3	1398	1.5	4.4	17.7	-	induct inlet	81	89	85	88	87	86	82	
									open inlet	79	88	85	88	87	86	82	75
									open outlet	79	91	88	91	91	90	86	79
12	TRAS100H-63	F	3	930	1.5	4	18	-	induct inlet	87	85	82	83	83	83	81	
									open inlet	86	85	82	83	83	83	81	72
									open outlet	86	88	85	86	87	87	85	75
13	TRAS80H-43	E	3	1398	2.7	7.5	5.3	-	induct inlet	87	93	86	88	86	85	82	
									open inlet	84	92	86	88	86	85	82	75
									open outlet	84	95	89	91	90	89	86	79
14	TRAS100L-43	F	3	1398	3	6.8	39	-	induct inlet	95	93	94	98	100	95	93	
									open inlet	94	93	94	98	100	95	93	86
									open outlet	94	96	97	101	104	99	97	90
15	TRAS100H-43	F	3	1398	5.5	11.9	84	28	induct inlet	98	95	93	95	96	91	93	
									open inlet	97	95	93	95	96	91	93	83
									open outlet	97	98	96	98	100	95	97	87

The electrical and sound information in the table is nominal. dBA@3m is hemispherical, free field.
 Start currents (sc) are DOL other than for motors of 4 kW and above which are star delta.
 * Motor electrical supply, 1=1 phase (230V, 50Hz) 3=3phase (400V, 50Hz).

PERFORMANCE - TERMINATOR ROOF EXTRACT FANS

Terminator TRC Centrifugal 21 - 30

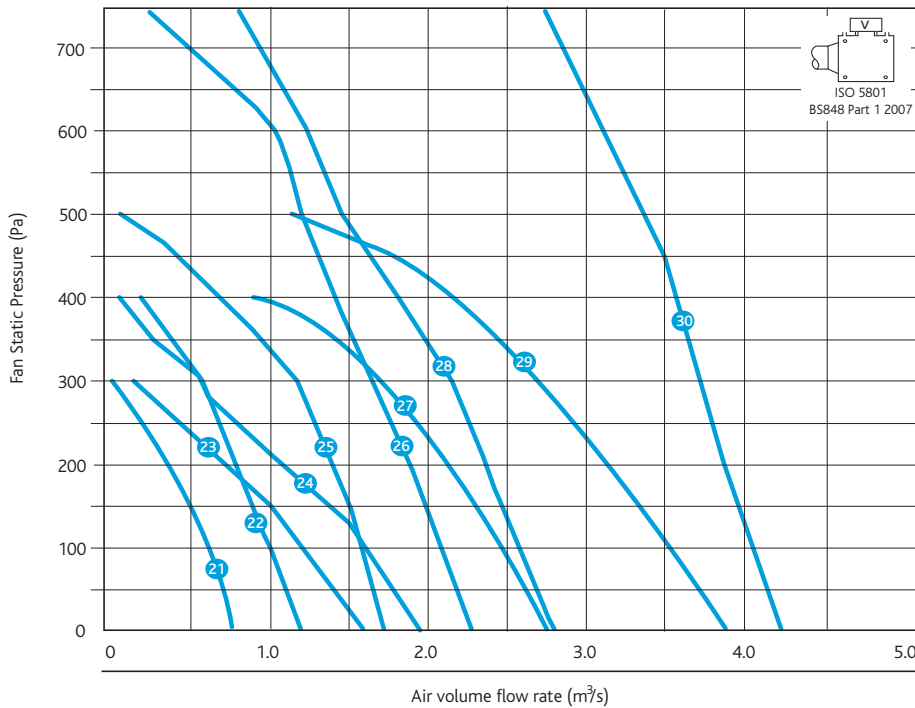

ELECTRICAL & SOUND CENTRIFUGAL IMPELLER TRC

Curve	Code	Cowl Size	Phase	RPM	Motor Power (kW)	FLC (amps)	SC (amps)	SC ★/▲	Induct inlet Open inlet Open outlet	Sound Power Levels (dB re 10 ⁻¹² W) Octave band mid frequency (Hz)							Open inlet/ outlet dBA@ 3m
										125	250	500	1K	2K	4K	8K	
21	TRCS350-41	A	1	1350	0.31	1.45	5.8	-	induct inlet open inlet open outlet	83 78 78	73 71 74	68 60 70	60 61 63	61 60 65	60 65 64	65 53 69	56
22	TRCS400-41	B	1	1345	0.52	2.4	9.6	-	induct inlet open inlet open outlet	86 81 81	76 74 77	71 70 73	63 63 66	64 63 68	63 68 67	68 56 59	
23	TRCS500-61	C	1	880	0.45	2.3	9.2	-	induct inlet open inlet open outlet	82 79 79	74 73 76	72 72 75	67 67 70	66 66 70	66 73 77	73 58 62	
24	TRCS560-61	C	1	835	0.67	3.3	13.2	-	induct inlet open inlet open outlet	89 86 86	78 77 80	72 72 75	69 69 72	69 67 71	67 73 77	73 60 63	
25	TRCS450-41	B	1	1265	0.74	3.5	14	-	induct inlet open inlet open outlet	90 86 86	80 79 82	75 75 78	68 68 71	69 68 73	68 73 77	73 61 64	
26	TRCS500-41	C	1	1360	1.35	6.1	24.4	-	induct inlet open inlet open outlet	91 88 88	83 82 85	81 76 84	76 75 79	75 75 79	75 82 86	82 67 71	
27	TRCS630-63	D	3	885	1.2	2.7	10.5	-	induct inlet open inlet open outlet	91 89 89	82 81 84	76 76 79	76 74 78	74 72 78	72 74 76	74 64 67	
28	TRCS560-43	C	3	1345	1.9	3.5	14	-	induct inlet open inlet open outlet	98 95 95	87 86 89	81 81 84	78 78 81	78 76 80	76 82 86	82 69 72	
29	TRCS710-63	D	3	880	1.95	3.9	19.5	-	induct inlet open inlet open outlet	91 89 89	86 85 88	79 79 82	83 81 86	81 78 85	78 78 82	78 70 73	
30	TRCS630-43	D	3	1370	3.7	6.5	32.5	-	induct inlet open inlet open outlet	100 98 98	91 90 93	85 85 88	85 83 88	83 81 87	81 83 85	83 73 76	

The electrical and sound information in the table is nominal. dBA@3m is hemispherical, free field. Start currents (sc) are DOL other than for motors of 4 kW and above which are star delta. *Motor electrical supply, 1=1 phase (230V, 50Hz) 3=3phase (400V, 50Hz). Note: The TRCS450-61 unit is no longer available for purchase.

PERFORMANCE - TERMINATOR ROOF EXTRACT FANS

ELECTRICAL & SOUND MIXED FLOW IMPELLER TRM

Curve	Code	Cowl		RPM	Motor Power (kW)	FLC (amps)	SC (amps)	SC ★/▲	Induct inlet Open inlet Open outlet	Sound Power Levels (dB re 10 ⁻¹² W)						Open inlet/ outlet dBA@ 3m		
		Size	Phase							Octave band mid frequency (Hz)								
											125	250	500	1K	2K	4K	8K	
16	TRMS450-61	B	1	860	0.18	1.55	3.5	-	induct inlet	76	74	70	66	66	60	52		
									open inlet	72	72	70	66	60	52	54		
									open outlet	72	75	73	69	70	64	56		58
17	TRMS350-41	A	1	1430	0.25	2.10	9.03	-	induct inlet	74	77	65	68	68	64	55		
									open inlet	69	75	64	68	68	64	55		56
									open outlet	69	78	67	71	72	68	59		59
18	TRMS560-61	C	1	850	0.55	6.6	14.8	-	induct inlet	79	82	75	73	72	70	65		
									open inlet	77	81	75	73	72	70	65		61
									open outlet	77	84	78	76	76	74	69		65
19	TRMS450-41	B	1	1335	0.55	3.6	10.8	-	induct inlet	79	78	76	75	75	69	61		
									open inlet	75	77	76	75	75	69	61		62
									open outlet	75	80	79	78	79	73	65		66
20	TRMS560-43	C	3	1430	1.5	4.4	17.7	-	induct inlet	83	87	81	82	81	79	74		
									open inlet	80	86	81	82	81	79	74		69
									open outlet	80	89	84	85	85	83	78		73

The electrical and sound information in the table is nominal. dBA@3m is hemispherical, free field. Start currents (sc) are DOL other than for motors of 4 kW and above which are star delta. * Motor electrical supply, 1=1 phase (230V, 50Hz) 3=3phase (400V, 50Hz).

DIMENSIONS - TERMINATOR ROOF FANS

DIMENSIONS (MM) & WEIGHT

Fan Units	Cowl Size	A	B	C	D (min)	E	F	Weight Kg
TRAS315-41	A	900	620	340	460 sq	150	600 sq	20
TRAS350-41	A	900	620	340	460 sq	150	600 sq	20
TRAS400-41	B	1080	740	375	560 sq	150	695 sq	30
TRAS450-41	B	1080	740	375	560 sq	150	695 sq	30
TRAS500-41	C	1320	964	475	700 sq	150	945 sq	45
TRAS500-61	C	1320	964	475	700 sq	150	945 sq	45
TRAS560-43	C	1320	964	475	700 sq	150	945 sq	45
TRAS560-61	C	1320	964	475	700 sq	150	945 sq	45
TRAS630-43	C	1470	1076	490	800 sq	200	1050 sq	63
TRAS630-61	D	1470	1076	490	800 sq	200	1050 sq	63
TRAS80H-43	E	1780	1170	485	900 sq	250	1136 sq	103
TRAS80L-43	E	1780	1170	485	900 sq	250	1136 sq	103
TRAS100H-43	F	2260	1476	600	1200 sq	250	1452 sq	144
TRAS100H-63	F	2260	1476	600	1200 sq	250	1452 sq	144
TRAS100L-43	F	2260	1476	600	1200 sq	250	1452 sq	144
TRCS350-41	A	900	620	340	460 sq	150	600 sq	20
TRCS400-41	A	1080	740	375	460 sq	150	695 sq	30
TRCS450-41	B	1080	740	375	560 sq	150	695 sq	30
TRCS500-41	C	1320	964	475	700 sq	150	945 sq	51
TRCS500-61	C	1320	964	475	700 sq	150	945 sq	51
TRCS560-43	C	1320	964	475	700 sq	150	945 sq	51
TRCS560-61	C	1320	964	475	700 sq	150	945 sq	51
TRCS630-43	D	1470	1076	490	800 sq	200	1050 sq	82
TRCS630-63	D	1470	1076	490	800 sq	200	1050 sq	82
TRCS710-63	D	1470	1076	490	800 sq	200	1050 sq	82

DIMENSIONS (MM) & WEIGHT

Fan Units	Cowl Size	A	B	C	D (min)	E	F	Weight Kg
TRMS350-41	A	900	620	340	460 sq	150	600 sq	23
TRMS450-41	B	1080	740	375	560 sq	150	695 sq	23
TRMS450-61	B	1080	740	375	560 sq	150	695 sq	35
TRMS560-43	C	1320	964	475	700 sq	150	945 sq	53
TRMS560-61	C	1320	964	475	700 sq	150	945 sq	53

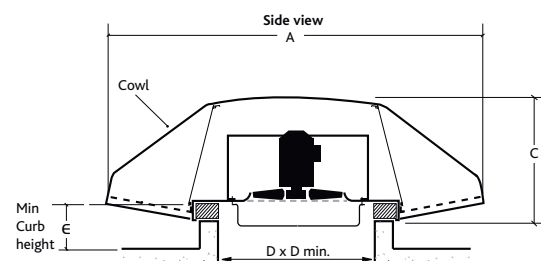
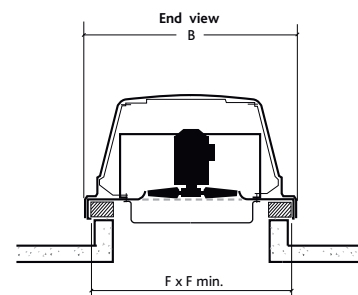

INSTALLATION

DIMENSIONS (mm)

Cowl Size	A	C	H	J	K
A	460	475	550	560	150
B	560	575	650	660	150
C	700	775	900	910	150
D	800	900	1000	1010	200
E	900	1000	1100	1110	250
F	1200	1300	1400	1410	250

Profile Roof Installation

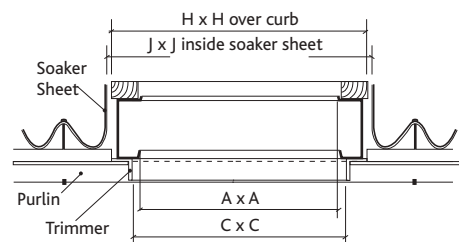

Note: Wooden curb and caps to be hardwood or treated softwood of minimum 50mm thickness.

Decking Roof Installation

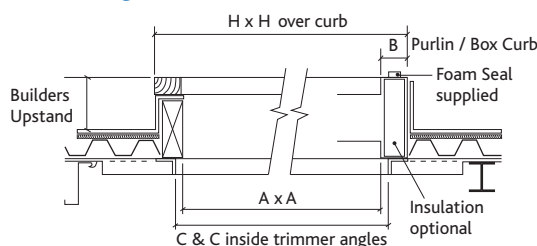

Vertical Profile Sheet Installation

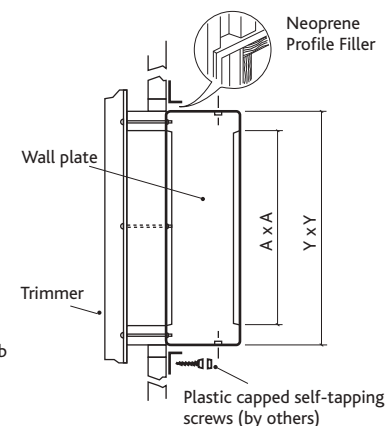

QUICK SELECTION GUIDE

TERMINATOR ROOF FANS

Fan Units	Cowl Size	Ecosmart Control Pack	Speed Controls Electronic	Frequency Inverter	Auto-transformer	Drop-in Standard Attenuator	Drop-in Long Attenuator	Roof Curb
TRAS315-41	A	-	NSC1-3A	-	SPCON3.5	TRDSS-A	TRDSL-A	PBC-A
TRAS350-41	A	-	NSC1-3A	-	SPCON3.5	TRDSS-A	TRDSL-A	PBC-A
TRAS400-41	B	-	NSC1-6A	-	SPCON3.5	TRDSS-B	TRDSL-B	PBC-B
TRAS500-61	C	-	NSC1-6A	-	SPCON3.5	TRDSS-C	TRDSL-C	PBC-C
TRAS560-61	C	-	NSC1-6A	-	SPCON3.5	TRDSS-C	TRDSL-C	PBC-C
TRAS450-41	B	-	NSC1-6A	-	SPCON3.5	TRDSS-B	TRDSL-B	PBC-B
TRAS630-61	D	-	NSC1-6A	-	SPCON7.5	TRDSS-D	TRDSL-D	PBC-D
TRAS500-41	C	-	NSC1-6A	-	SPCON7.5	TRDSS-C	TRDSL-C	PBC-C
TRAS560-41	C	-	NSC1-10A	-	SPCON7.5	TRDSS-C	TRDSL-C	PBC-C
TRAS560-43	C	ES-ISC3.3	-	3ISC3.3A	-	TRDSS-C	TRDSL-C	PBC-C
TRAS630-43	D	ES-ISC5.6	-	3ISC5.6A	-	TRDSS-D	TRDSL-D	PBC-D
TRAS80H-43	E	ES-ISC12.5	-	3ISC12.5A	-	TRDSS-E	TRDSL-E	PBC-E
TRAS80L-43	E	ES-ISC5.6	-	3ISC5.6A	-	TRDSS-E	TRDSL-E	PBC-E
TRAS100H-43	F	ES-ISC13.2	-	3ISC13.2A	-	TRDSS-F	TRDSL-F	PBC-F
TRAS100H-63	F	ES-ISC5.6	-	3ISC5.6A	-	TRDSS-F	TRDSL-F	PBC-F
TRAS100L-43	F	ES-ISC7.3	-	3ISC7.3A	-	TRDSS-F	TRDSL-F	PBC-F
TRMS350-41	A	-	NSC1-3A	-	SPCON7.5	TRDSS-A	TRDSL-A	PBC-A
TRMS450-41	B	-	NSC1-6A	-	SPCON7.5	TRDSS-B	TRDSL-B	PBC-B
TRMS450-61	B	-	NSC1-3A	-	SPCON3.5	TRDSS-B	TRDSL-B	PBC-B
TRMS560-43	C	ES-ISC5.6	-	3ISC5.6A	-	TRDSS-C	TRDSL-C	PBC-A
TRMS560-61	C	-	NSC1-10A	-	SPCON7.5	TRDSS-C	TRDSL-C	PBC-C
TRCS350-41	A	-	NSC1-3A	-	SPCON3.5	TRDSS-A	TRDSL-A	PBC-A
TRCS400-41	A	-	NSC1-3A	-	SPCON7.5	TRDSS-A	TRDSL-A	PBC-A
TRCS450-41	B	-	NSC1-6A	-	SPCON7.5	TRDSS-B	TRDSL-B	PBC-B
TRCS500-41	C	-	NSC1-10A	-	SPCON7.5	TRDSS-C	TRDSL-C	PBC-C
TRCS500-61	C	-	NSC1-10A	-	SPCON7.5	TRDSS-C	TRDSL-C	PBC-C
TRCS560-43	C	-	-	-	-	TRDSS-C	TRDSL-C	PBC-C
TRCS560-61	C	-	NSC1-6A	-	SPCON7.5	TRDSS-C	TRDSL-C	PBC-C
TRCS630-43	D	-	-	-	-	TRDSS-D	TRDSL-D	PBC-D
TRCS630-63	D	-	-	-	-	TRDSS-D	TRDSL-D	PBC-D
TRCS710-63	D	-	-	-	-	TRDSS-D	TRDSS-D	PBC-D

PERFORMANCE - TERMINATOR ROOF INPUT/SUPPLY FANS TIA

Terminator TIA

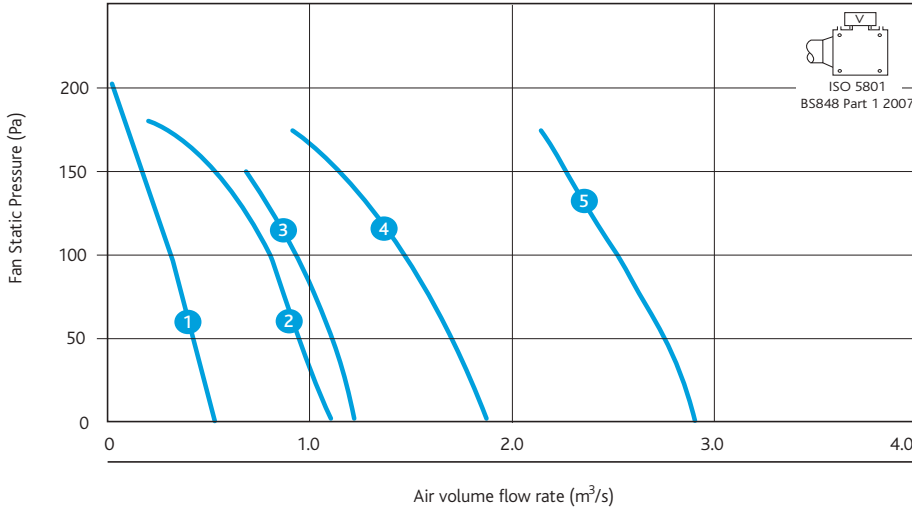

TIA - Roof mounted input/supply fan is supplied complete with Bird Guards and Motor side Finger guard.

ELECTRICAL & SOUND TIA

Curve	Code	Cowl Size	Phase	RPM	Motor Power (kW)	FLC (amps)	SC (amps)	Open inlet Open outlet	Sound Power Levels (dB re 10 - 12W) Octave band mid frequency (Hz)							Open inlet/ outlet dBa@ 3m
									125	250	500	1K	2K	4K	8K	
1	TIA350-421	A	1	1350	0.09	0.85	1.45	I O	85 78	83 81	75 77	68 72	64 68	58 63	51 54	78 61
2	TIA400-431	B	1	1350	0.25	1.8	3.6	I O	90 84	92 90	84 86	77 81	73 78	65 71	61 63	87 69
3	TIA450-441	B	1	1350	0.25	1.8	3.6	I O	88 87	88 92	81 87	76 83	71 80	65 74	56 66	83 72
4	TIA500-451	C	1	1350	0.55	3.6	10.8	I O	98 96	96 96	88 86	83 87	81 84	74 78	64 69	92 75
5	TIA630-473	D	3	1350	1.5	4.4	17.7	I O	101 101	98 98	92 93	88 95	86 91	79 86	73 77	95 81

I = Open Inlet O = Open Outlet
 The electrical and sound information in the table is nominal. *Open outlet dBA@3m input/supply.

DIMENSIONS - TERMINATOR ROOF INPUT/SUPPLY FANS TIA

DIMENSIONS (mm) & WEIGHT

Code	A	B	C	D (min)	E	F	Weight Kg
TIA350-421	900	620	340	460 sq	150	600 sq	20
TIA400-431	1080	740	375	560 sq	150	695 sq	30
TIA450-441	1080	740	375	560 sq	150	695 sq	30
TIA500-451	1320	964	475	700 sq	150	945 sq	45
TIA630-473	1470	1076	490	800 sq	200	1050 sq	63

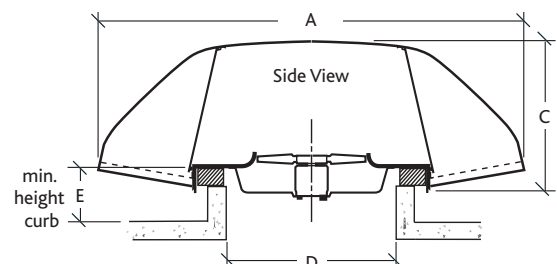
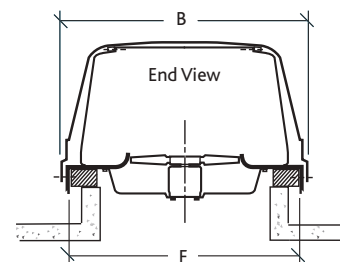

QUICK SELECTION GUIDE

TERMINATOR TIA

Fan Code	Drop In Standard Attenuator	Drop In Long Attenuator	Roof Curb
TIA350-421	TRDSS-A	TRDSL-A	PBC-A
TIA400-431	TRDSS-B	TRDSL-B	PBC-B
TIA450-441	TRDSS-B	TRDSL-B	PBC-B
TIA500-451	TRDSS-C	TRDSL-C	PBC-C
TIA630-473	TRDSS-D	TRDSL-D	PBC-D

Soaker sheets and flashing plates are available to suit all roof profiles. Contact Nuair for details.

ROOF FANS

TERMINATOR

TECHNICAL INFORMATION

DIMENSIONS - WALL FRAME KIT

DIMENSIONS (mm)					
Unit	A	B	C	D	E
A	550	250	400	369*	475
B	650	250	500	470*	575
C	900	250	700	610*	825
D	1000	250	800	690**	900

* Three holes equally spaced. ** Four holes equally spaced

Wall Mounting Kits

Note: unit must be installed using the appropriate wall mounting plate and with the longer cowl dimension running horizontally.

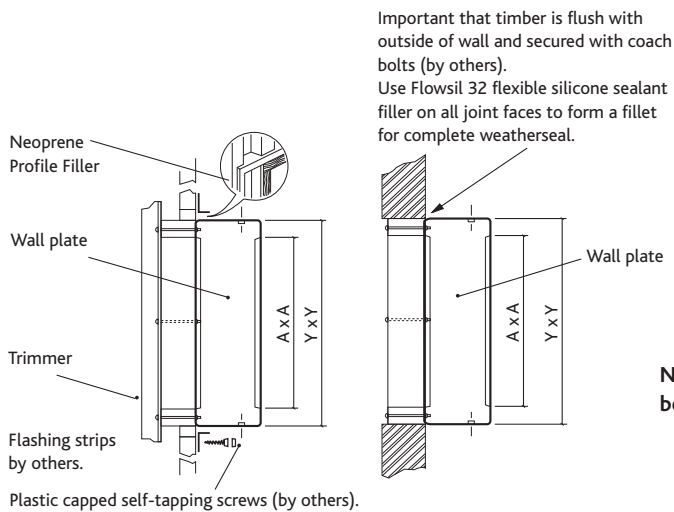

Roof profile prepared to accept a Purlin Box Curb.

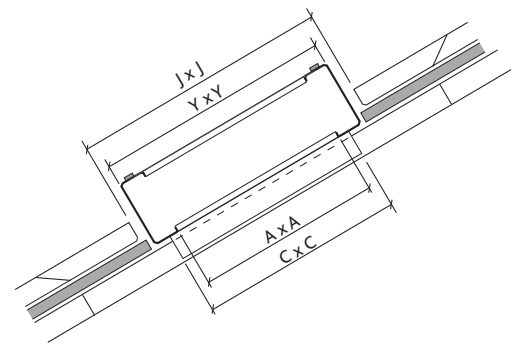
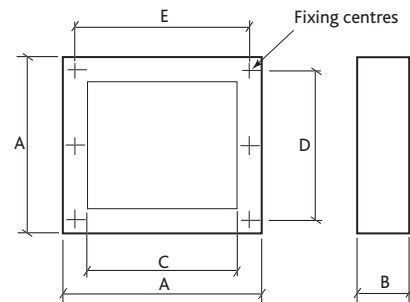

Note: Details of Terminator Cowls and Supply/Extract Cowls can be found on page 407.

TERMINATOR DAMPERS

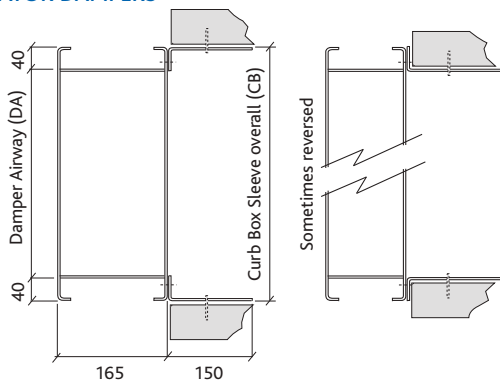

Built up Damper unit and Curb Box Sleeve

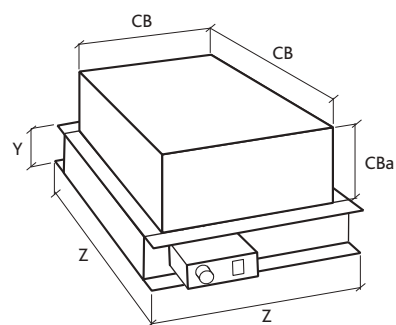

DIMENSIONS - DAMPERS

DIMENSIONS (mm)						
Damper Code	X	Y	Z	CB	Cba	Kg
TRDM-A	390	105	470	454	150	11
TRDM-B	490	105	570	551	150	14
TRDM-C	690	105	770	691	150	20
TRDM-D	800	105	880	793	150	25
TRDM-E	900	105	980	891	150	28
TRDM-F	1200	105	1280	1191	150	31

Damper motor fitted is "Motor open/Motor closed".
For Motor open/Spring Return option add 'S' after terminal size e.g. TRDM-A-S.

Motorised Damper unit

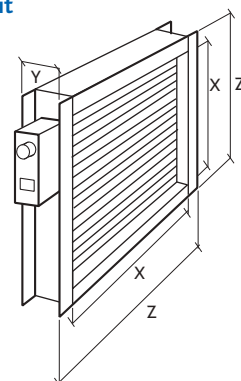

TERMINATOR DROP IN SILENCERS

Standard Attenuator

DIMENSIONS (mm) & WEIGHTS

Cowl	Unit Code	Type	Unit Size	A	B	C	E	Weight	Z
A	TRDSS-A	Standard	315	550	450	670	12	30	47
A	TRDSS-A	Standard	350	550	450	670	12	30	47
B	TRDSS-B	Standard	400	650	550	825	16	46	38
B	TRDSS-B	Standard	450	650	550	825	16	46	38
C	TRDSS-C	Standard	500	790	690	720	16	53	32
C	TRDSS-C	Standard	560	790	690	720	16	53	32
D	TRDSS-D	Standard	630	880	780	720	24	66	12.4
E	TRDSS-E	Standard	800	980	880	720	24	66	8.6
F	TRDSS-F	Standard	1000	1280	1180	800	32	170	2.6

Standard Attenuator Insertion Losses

Frequency Hz	125	250	500	1K	2K	4K	8K
Dynamic Attenuation (dB)	-5	-8	-13	-20	-21	-18	-14

Long Attenuator

DIMENSIONS (mm) & WEIGHTS

Cowl	Unit Code	Type	Unit Size	A	B	C	E	Weight	Z
A	TRDSL-A	Long	315	550	450	1120	12	40	47
A	TRDSL-A	Long	350	550	450	1120	12	40	47
B	TRDSL-B	Long	400	650	550	1275	16	74	38
B	TRDSL-B	Long	450	650	550	1275	16	74	38
C	TRDSL-C	Long	500	790	690	1170	16	85	32
C	TRDSL-C	Long	560	790	690	1170	16	85	32
D	TRDSL-D	Long	630	880	780	1170	24	104	12.4
E	TRDSL-E	Long	800	980	880	1170	24	104	8.6
F	TRDSL-F	Long	1000	1280	1180	1250	32	281	2.6

Long Attenuator Insertion Losses

Frequency Hz	125	250	500	1K	2K	4K	8K
Dynamic Attenuation (dB)	-10	-16	-26	-40	-40	-35	-26

CURBING

PREFABRICATED CURB DIMENSIONS (mm)

Curb Code	A	B	C	D
PBC A	550	550	250	45
PBC B	650	650	250	45
PBC C	900	900	250	100
PBC D	1000	1000	250	100
PBC E	1100	1100	350	100
PBC F	1400	1400	325	100

Dims internal or external. Manufactured in galvanised steel these curbs will reduce design work and guarantee correct unit mounting when on site.

Note: Upper faces of curb are fitted with robust sealing strip.

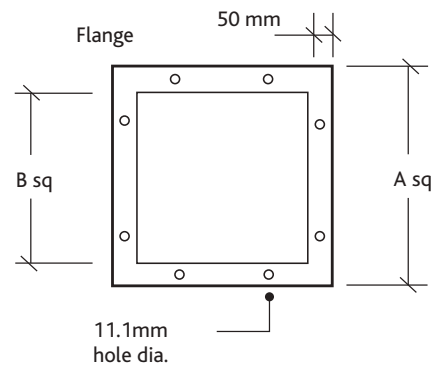
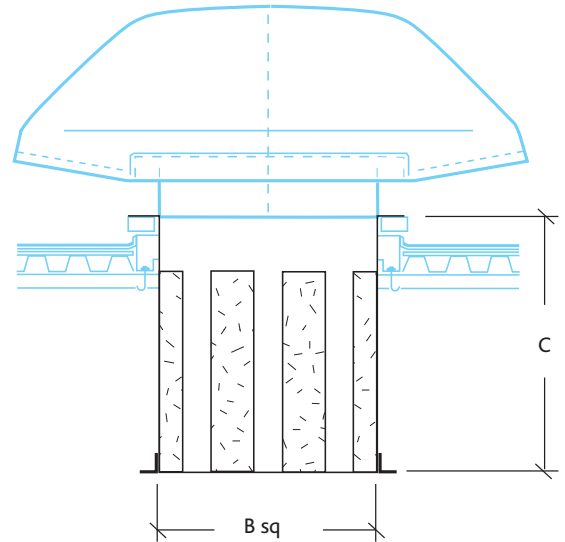

Note: Air Pressure Drop of Attenuator (Pa) = Z x Q² where Z = Factor listed in table right
 Q = Air Volume Flow Rate (m³/s)

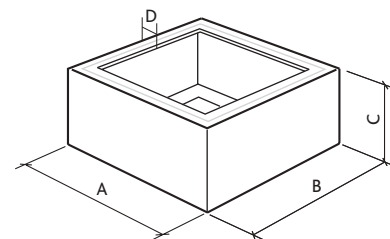

WIRING FOR TERMINATOR TRA, TRM, TRC AND TIA UNITS (EXCEPT TRA 100H-43)

(Single phase units - 3 wire supply)

Single Speed 1 Phase

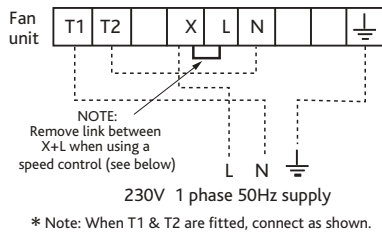

Single Speed 3 Phase

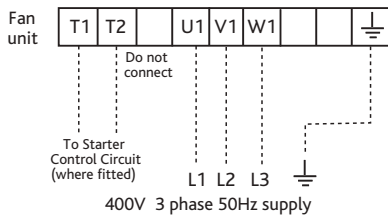

Speed Control, Transformer 1 Phase

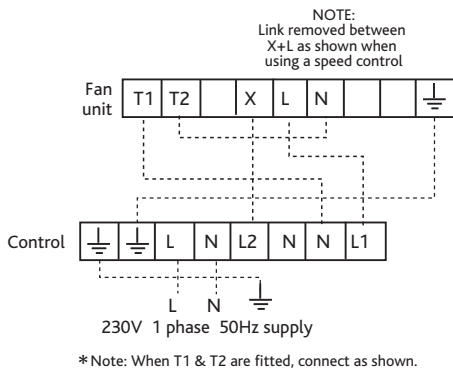

(Single phase units - 3 wire supply)

Speed control, Electronic 1 Phase

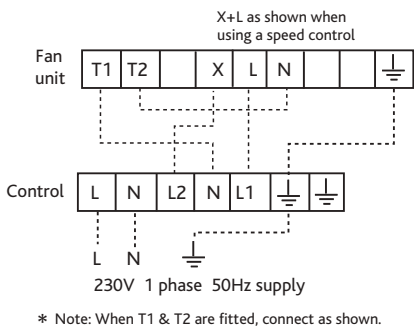

Ecosmart

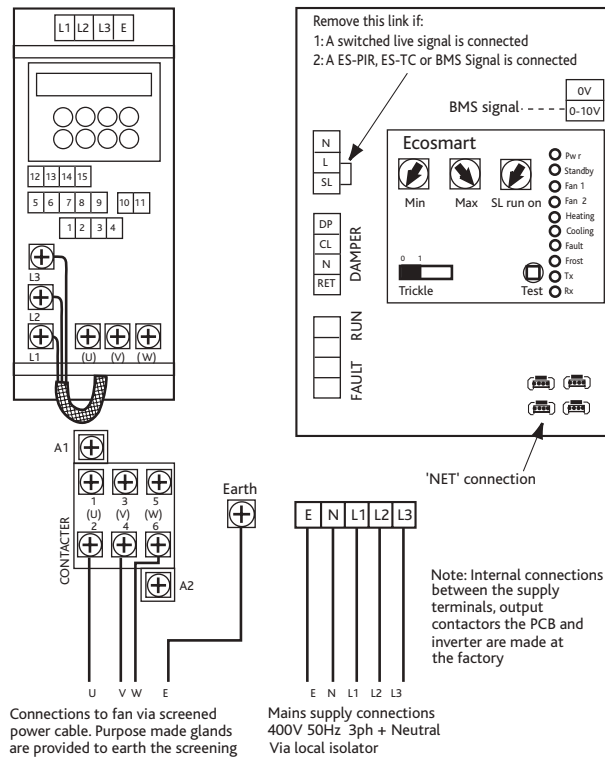

TRA100H-43 3 Phase

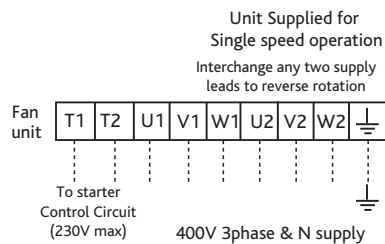

Unit Wiring

The terminator range of units are pre-wired from the motor to an enclosed terminal box. On TRA (axial) models this box is located at the end of a 600mm long flexible conduit which hangs underneath and is fixed to a convenient surface by the installer. These units will require bottom access to complete wiring.

On TRM (mixed flow) and TRC (centrifugal) models the box is located on the fan plate or motor bridge inside the cowl. On these units it will be necessary to remove the cowl to gain access.

When wiring in the unit take care to avoid rotating components and also gravity shutters. 20mm holes are provided in the fan base plate to bring wiring out from inside the building.

Connection details

Check that the electrical supply is compatible with the unit (see unit rating plate). Connection details are supplied with speed controls.

All wiring must be done in accordance with regulations for electrical installations and comply with the requirements of the local supply authority.

Ensure that the direction of rotation is correct. Single phase units are checked during manufacture for correct rotation. Three phase units must be tested on site and, if incorrect, interchange any two supply leads to reverse impeller direction.

CONTROLS

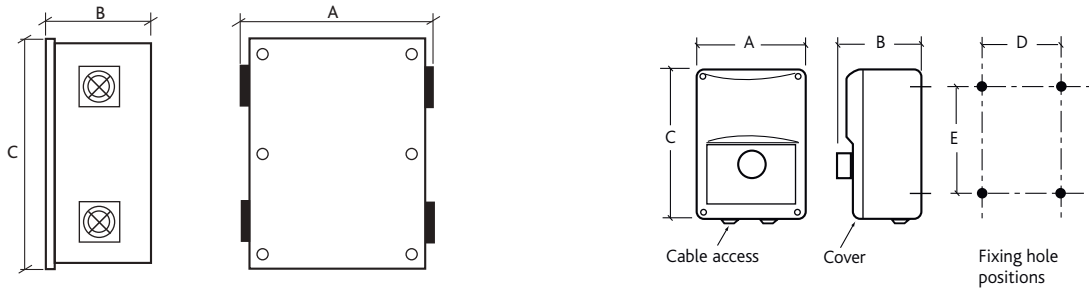

ECOSMART CONTROL (mm)

Fan Code	A mm	B mm	C mm	Weight Kg
ES-ISC1.2A	325	230	410	6
ES-ISC2.1A	325	230	410	6
ES-ISC3.0A	325	230	410	6
ES-ISC4.0A	325	230	410	6
ES-ISC5.9A	390	290	455	14
ES-ISC7.7A	390	290	455	14
ES-ISC10.2A	390	290	455	14
ES-ISC13.2A	390	290	455	20
ES-ISC18.4A	390	290	455	20
ES-ISC26.0A	390	290	455	20
ES-ISC38.0A	525	290	805	40

Please note:

- The mains power supply to the controller must be appropriately sized and installed via a local isolation switch (by others). The isolator must also accommodate the switched live (if used). The mains supply from the ecosmart controller to the fan must be appropriately sized, not exceeding 25 metres and must be a screened power cable, earthed at both ends. A four point glanding plate is formed from the base of the control and in order to main EMC compliance, a Zerohm EMC glanding kit is supplied. An isolator should be located adjacent to the fan.
- Contra and run and standby fans will require two controls, one for each fan.
- All integrated sensors plug directly into the control panel.
- Refer to product datasheet No. 671193 for further information.

ELECTRONIC SPEED CONTROL (mm)

Unit Code	A	B	C	D	E	Weight Kg
NSC1-3A	83	88	180	71	108	0.5
NSC1-6A	115	95	195	98	140	0.7
NSC1-10A	115	95	195	98	140	0.7

The electronic speed controllers provide infinitely variable speed control from preset minimum to maximum. All models feature a boost start function, which applies maximum power to the motor for a few seconds to prevent motor stalling before returning to selected speed. Wiring to the motor can be either 2-wires or 3-wires control depending on the motor design. The enclosures for ESC1-3A and ESC1-6A are rated to IP45 with the ESC1-10A rated at IP54. All controllers meet LVD and EMC directives for safety and electromagnetic compatibility.

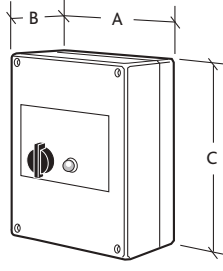

TRANSFORMER SPEED CONTROL (mm)

Single Phase		A	B	C	Weight Kg
Unit Code					
SPCON1.5		115	85	180	1.7
SPCON3.5		200	140	280	3.6
SPCON7.5		200	140	280	6

Autotransformers having class 'F' insulation are used to provide discrete voltage steps. All models are fitted with suitable fuses for short-circuit protection. The controller casing is manufactured from plastic pre-coated steel or impact resistant polycarbonate. All models are suitable for indoor installations only. All controllers meet LVD and EMC directives for safety and electromagnetic compatibility. Transformer speed controls produce a pure sine wave output resulting in quiet motor operation. Transformer controls are therefore preferred for noise sensitive applications.

INVERTER SPEED CONTROL

DIMENSIONS (MM)

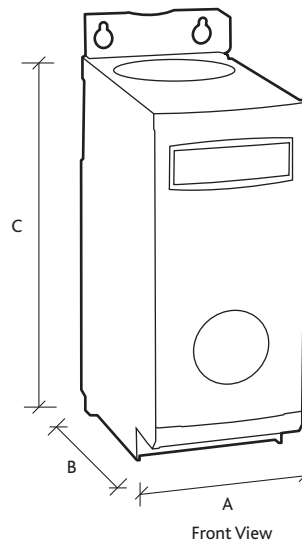

These are a range of frequency inverters for controlling the speed of 3 phase AC motors. Standard range are 400V 3 phase input units covering motor rating from 0.75kW to kW. Higher ratings and single phase input models are available upon request.

The inverters are microprocessor controlled and use state of the art Insulated Gate Bipolar Transistor (IGBT) technology. This makes them reliable and versatile. A special pulse-width modulation method with selectable pulse frequency permits quiet motor operation.

Comprehensive protective functions provide excellent inverter and motor protection.

The inverters default factory settings, is ideal for a large range of simple motor control applications. The inverters can also be used for more advanced motor control applications via its comprehensive parameter lists. The inverters can be used in both 'stand alone' applications as well as being integrated into 'Automation systems'.

Fan code	Motor Kw	A	B	C	Weight Kg
3ISC1.2A	0.37	70	142	280	1.5
3ISC1.9A	0.35	70	142	280	1.5
3ISC2.4A	0.75	70	142	280	1.7
3ISC3.3A	1.1	70	142	280	1.7
3ISC4.1A	1.5	70	142	280	1.7
3ISC5.6A	2.2	70	142	280	1.7
3ISC7.3A	3	70	142	280	1.7
3ISC8.8A	4	70	142	280	1.7
3ISC12.5A	5.5	169	177	299	3.5
3ISC15.6A	7.5	169	177	299	3.5
3ISC23.1A	11	169	177	299	3.5
3ISC31.0A	15	260	177	320	5
3ISC38.0A	18.5	260	177	320	5
3ISC44.0A	22	260	177	320	5
3ISC59.0A	30	260	177	320	24
3ISC72.0A	37	260	177	320	24
3ISC87.0A	45	260	177	320	24

Code descriptions

3 ISC 1.2A



- 1. 3 Phase supply
- 2. Inverter Speed Control
- 3. Output Current Rating

CONSULTANTS SPECIFICATION

FAN DESCRIPTION

The Roof mounted extract/supply fans shall be located in the positions indicated on the drawings and in accordance with the relevant fan schedule. It shall be a low profile cowl manufactured in flame retardant GRP.

The fan shall be of the Terminator type and shall be supplied complete with backdraught shutters, birdguard, purlin box curb, hand guard, specific details of the curb and and purlin to be confirmed by the main contractor.

The mechanical contractor shall make due allowance for supporting the fan via the provision of purpose made trimmers between purlin. The trimmers shall be sized to adequately support the weight of the fans.

The Fan unit shall have a 3 year warranty, first year parts and labour the remainder parts only. Ecosmart Terminator shall have a 5 year warranty, first year parts and labour the remainder parts only.

The unit and ancillaries shall be of the Terminator type as manufactured by Nuaire Ltd.

CONTROL SPECIFICATION

The fan unit can be supplied with one of the following control options:-

1. Ecosmart controls (3 phase only)

The compact Ecosmart control system complete with all necessary controls to facilitate the operation of the ventilation system. It shall be come complete with an integral factory fitted Ecosmart PCB which will control the fan unit within the desired design parameters and provide the interface between all external control devices and the unit itself.

The fan unit shall have the following energy saving components integrally mounted, pre-wired to interface with the purpose made PCB, all components pre-wired, configured and factory fitted by the manufacturer: -

- Integral Frequency inverter/speed controller.
- Integral maximum and minimum speed adjustment for commissioning.
- Integral adjustable run on timer.
- Integral BMS interfaces – 0-10V speed adjustment.
- Integral BMS interfaces – Volt free failure and status indication.
- Integral background ventilation switch (trickle switch).
- Multiple IDC sockets for interconnection of sensors or fans using pre-plugged 4-core low voltage cable.

ECOSMART SYSTEM OPERATION

The Ecosmart controls will enable the unit to automatically vary its speed as it receives signals from one of the interconnected sensors. When the signal is received the fan shall either increase speed gradually until the required level is achieved or it will work on a trickle and boost principle. This will then move the fan duty point from trickle/background ventilation rate to the required boost ventilation rate. Both the trickle and boost rates are infinitely variable, easy to adjust and remove the need of a main balancing damper.

2. BMS INTERFACES

The fan unit can be provided with the following integrated BMS interfaces

- 0 - 10 volt contacts to provide a full BMS interface. This will enable the following functions:-
 - Switch the unit on/off.
 - Switch from low speed to high speed.
 - Full speed control facility.
- 2 No. Volt free contacts to provide fan run and failure indication to provide system status.
- An integrated commissioning/speed control to accurately commission the system, with minimum and maximum speeds easily adjusted via a miniature dial, as recommended in Part L. This will enable the unit to be configured to run between set parameters thus saving motor power and limiting noise.

3. COMMISSIONING SET UP

The fan unit can be provided with an integrated commissioning/speed control to accurately commission the system, as recommended in Part L, minimum and maximum speeds easily adjusted via miniature dial. The commissioning set up facility directly controls the integrated speed control/frequency inverter.

4. STANDARD CONTROLS

The unit shall be provided with a standard speed control or starter in accordance with the manufacturers recommendations.

Terminator has a 3 year warranty.

Ecosmart Terminator has a 5 year warranty.

All equipment shall be as manufactured by Nuaire Ltd.

ROOF COWLS AND TERMINALS

TERMINATOR COWLS DIMENSIONS (mm)

To provide a weatherproof route for supply & exhaust air to your ducted system.

Cowls are manufactured from flame retardant polymer and can be supplied with gravity backdraught shutters, bird guards and hand guards. The terminal is finished in BS00A05 Grey as standard. All BS or RAL colours are available. The cowl will normally be fitted to the upstand by a roofing contractor or builder. The Cowl can be fitted without shutters on a 0-60 degree pitched roof with its longer side running down the roof slope. The Cowl can be fitted with its longer side running across a slope of less than 85 degrees from the horizontal. When fitted to a wall the longer side must run horizontal.

Typical code: TRTS-A Note: S = Shutters

Note: Air Pressure Drop of Cowl (Pa) = Z x Q²

where Z = Factor listed in table below Q = Air Volume Flow Rate (m³/s)

Code	A	B	C	D	E	H	Weight Kg	Z Extract	Z Intake
TRTS-A	900	620	340	460	600	550	16.3	67	118
TRTS-B	1080	740	375	560	695	650	20.7	39	87
TRTS-C	1320	964	475	700	945	900	34.4	28	62
TRTS-D	1470	1076	490	800	1050	1000	39.2	19	32
TRTS-E	1780	1170	485	900	1136	1100	66.8	7	11.3
TRTS-F	2260	1476	600	1200	1452	1400	114	2.5	3.6

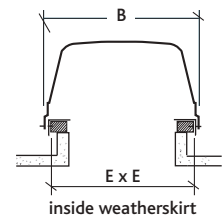
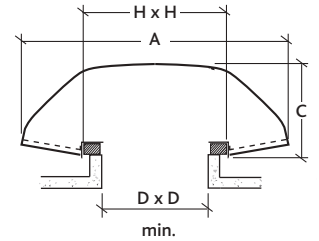

SUPPLY/EXTRACT COWLS DIMENSIONS (mm)

Supply/Extract Cowl: rigid flame retardant cowl, conforming with BS476 (Part 1 class 11) supplied in grey (BS 00 A 05) as standard (any BS or RAL colours available), fixing directly to the base using non-rusting sealed fixings. Air plenum is manufactured from galvanised steel incorporating supply & extract chambers. Rigid spigots are provided for connection of duct work. Supply & extract chamber is fitted with a bird guard.

Typical code: TRSE1

Code	A	B	C	D	E	F	G	H	Weight Kg
TRSE1	900	620	340	460	600	200	100	550	21.3
TRSE2	900	620	340	460	600	200	125	550	21.3
TRSE3	900	620	340	460	600	200	150	550	21.3
TRSE4	1320	964	475	700	945	345	200	900	41.4
TRSE5	1320	964	475	700	945	345	250	900	41.4
TRSE6	1320	964	475	700	945	345	315	900	41.4
TRSE7	1780	1170	489	900	1150	450	400	1100	76.8

Resistance to airflow of this item is negligible.

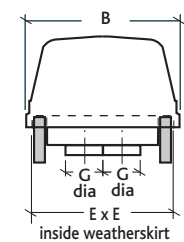
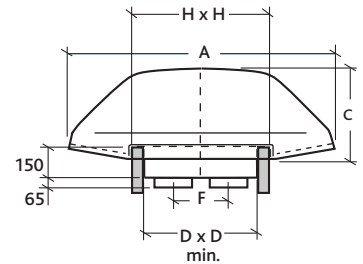

ROOF FANS

ROOF COWLS AND TERMINALS

TECHNICAL INFORMATION

ROOF COWLS AND TERMINALS CONT.

FILTERED TERMINALS DIMENSIONS (mm)

Low profile terminals are to be supplied by Nuair. The terminal is to be rectangular, constructed in aluminium alloy and with non-rusting fixings. Twin inlets fitted with inlet/bird guards and an integral weather skirt. Filtered units are to be fitted with filter frames for removal and replacement of BS2831 and BS2963 filters.

Typical code: 630LPDT/1 - Disposable Filter. 630LPWT/1 - Washable Filter.

Code	A	B	C	D	Weight Kg	Z Extract	Z Intake
630LP*T/1	1250	700	280	690	15.1	67	106
800LP*T/1	1390	800	350	790	25.2	51	88
1400LP*T/1	2620	1800	600	1440	91.0	3.3	6.5

Note:* D = Disposable *W= Washable

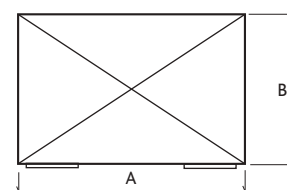
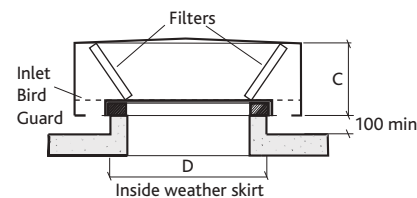

Optional Access Panels,
filters withdraw from one side

NON-FILTERED TERMINALS (mm)

Low profile terminals are to be supplied by Nuair. The terminal is to be rectangular, constructed in aluminium alloy and with non-rusting fixings. Twin inlets fitted with inlet/bird guards and an integral weather skirt.

Typical code: 315LPT/1

Note: Air Pressure Drop of Cowl (Pa) = $Z \times Q^2$

where: Z = Factor listed in table below Q = Air Volume Flow Rate (m³/s)

Code	A	B	C	D	Weight Kg	Z Extract	Z Intake
315LPT/1	615	400	150	390	3.5	553	614
400LPT/1	745	500	165	490	5.8	222	296
500LPT/1	915	600	200	590	8.1	105	117
630LPT/1	1350	700	280	690	12.6	48	29
800LPT/1	1390	800	350	790	23.5	32	21
1000LPT/1	1820	1050	420	1040	29.8	13	10
1120LPT/1	2070	1150	500	1140	35.0	6.5	4.6
1250LPT/1	2204	1250	540	1240	41.0	5	4
1400LPT/1	2620	1800	600	1440	65.0	1	1

