

MRXBOXAB-ECO2 MRXBOX-ECO2 and Opposite Handed versions

ACHIEVES
100%
DUTY IN BYPASS
MODE

The MRXBOXAB-ECO2 has been designed with automatic 100% bypass as listed on the SAP Product Characteristics Database (PCDB).

Due to its intelligent and smart design, there will be no reduction in airflow when operating in bypass mode resulting in enhanced performance.

Both the MRXBOXAB-ECO2 and the MRXBOX-ECO2 are designed to provide optimised balanced (supply and extract) mechanical ventilation with heat recovery and both are listed on the PCDB.

The units operate by continuously extracting moisture-laden air from 'wet' rooms within the property and at the same time drawing in fresh supply air from outside. The heat from the extracted stale air is recovered via a heat exchanger inside the heat recovery unit which becomes tempered then filtered before supplying into the habitable rooms, creating comfortable and well ventilated homes.

The heat exchanger block within these units can recover up to 95% of the normally wasted heat. The two independent fans have full-speed control for background and boost ventilation rates.

The MRXBOXAB-ECO2 has a Summer bypass function. In warmer months this function automatically activates to ensure the property is being well-ventilated and comfort levels are maintained in the home by continuously drawing in fresh filtered air into the habitable rooms.



Typical Installation ▼

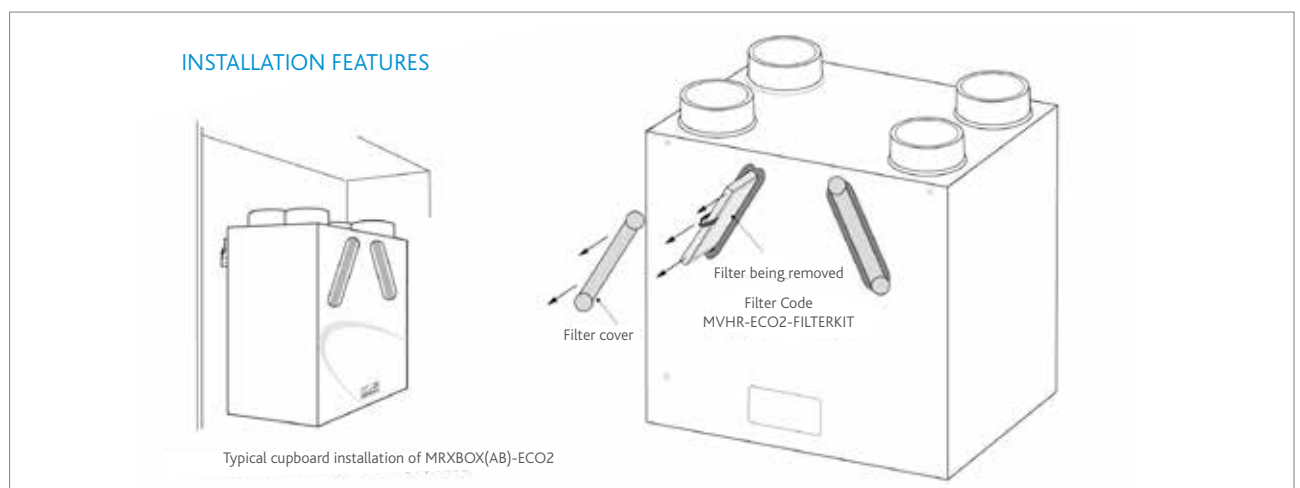

Performance - MRXBOX(AB)-ECO2 ▼

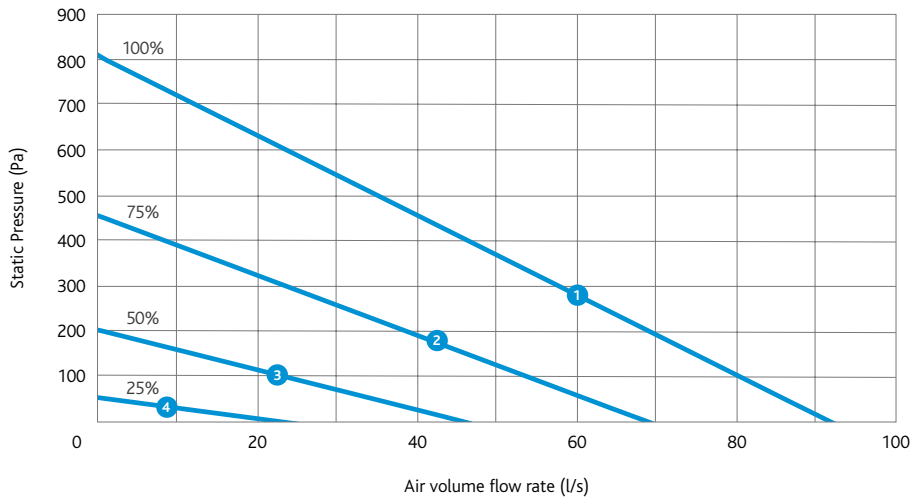

CODE DESCRIPTION

MRXBOXAB-ECO2

Wall mounted unit with 100% bypass and integral humidistat.

MRXBOX-ECO2

Wall mounted unit.

MRXBOXAB-ECO2-OH

Opposite handed configuration wall mounted unit with 100% bypass and integral humidistat.

MRXBOX-ECO2-OH

Opposite handed configuration wall mounted unit.

Electrical & Sound ▼

| Curve | Maximum power consumption (Watts) | | Sound Power Levels dB re 1pW (Frequency Hz) | | | | | | | | dBA @3m |
|-------|-----------------------------------|-------------|---|-----|-----|-----|-----|-----|-----|-----|---------|
| | | | 63 | 125 | 250 | 500 | 1k | 2k | 4k | 8k | |
| 1 | 155 | Open inlet | 48 | 52 | 59 | 55 | 50 | 46 | 35 | 27 | |
| | | Open outlet | 60 | 67 | 69 | 69 | 64 | 64 | 54 | 46 | |
| | | Breakout | 59 | 60 | 58 | 59 | 49 | 46 | 35 | 27 | 40 |
| 2 | 69 | Open inlet | 44 | 47 | 57 | 50 | 45 | 41 | 30 | 21 | |
| | | Open outlet | 55 | 63 | 63 | 65 | 60 | 59 | 49 | 40 | |
| | | Breakout | 56 | 57 | 53 | 52 | 44 | 40 | 28 | 18 | 34 |
| 3 | 19 | Open inlet | 39 | 38 | 48 | 40 | 35 | 29 | 16 | <16 | |
| | | Open outlet | 48 | 54 | 53 | 55 | 49 | 47 | 35 | 24 | |
| | | Breakout | 43 | 48 | 44 | 42 | 34 | 29 | <16 | <16 | 24 |
| 4 | 7 | Open inlet | 38 | 31 | 27 | 23 | <16 | <16 | <16 | <16 | |
| | | Open outlet | 38 | 34 | 31 | 31 | 22 | <16 | <16 | <16 | |
| | | Breakout | 37 | 31 | 24 | 20 | <16 | <16 | <16 | <16 | <16 |

The maximum power consumption shown above (Watts) is consumed on units running continuously, not taking into account any heat recovery saving and based on SAP Product Characteristic Database (PCDB) testing. The breakout case-radiated dBA values are given for Hemispherical free field radiation at 3m - to obtain the Spherical radiated data, subtract 3 dBA.

Please note: Sound data is provided at a particular duty point for 25%, 50%, 75% and 100%. For accurate sound data at a specific speed duty, please use Nuair's fan selector or call the office on 029 2085 8500.

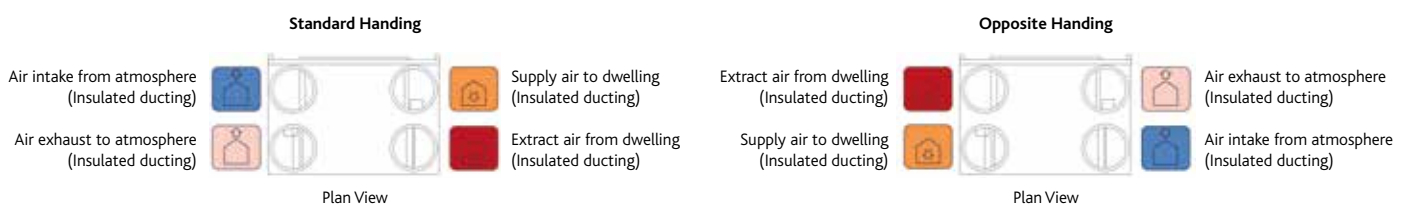

MRXBOXAB-ECO2
& MRXBOX-ECO2

SAP 2009 Test Results ▼

| Product Code | MRXBOXAB-ECO2 | | | MRXBOX-ECO2 | | |
|----------------------|----------------------------|--------------------------|---|----------------------------|--------------------------|---|
| Application | Specific Fan Power (W/l/s) | Heat Exchange Efficiency | Energy Saving Trust Best Practice Compliant | Specific Fan Power (W/l/s) | Heat Exchange Efficiency | Energy Saving Trust Best Practice Compliant |
| Kitchen + 1 Wet Room | 0.49 | 90% | Yes | 0.46 | 90% | Yes |
| Kitchen + 2 Wet Room | 0.50 | 90% | Yes | 0.45 | 89% | Yes |
| Kitchen + 3 Wet Room | 0.58 | 89% | Yes | 0.50 | 89% | Yes |
| Kitchen + 4 Wet Room | 0.69 | 88% | Yes | 0.60 | 88% | Yes |
| Kitchen + 5 Wet Room | 0.81 | 87% | Yes | 0.70 | 87% | Yes |

SAP 2012 Test Results ▼

| Product Code | MRXBOXAB-ECO2 | | | MRXBOX-ECO2 | | |
|----------------------|----------------------------|--------------------------|---|----------------------------|--------------------------|---|
| Application | Specific Fan Power (W/l/s) | Heat Exchange Efficiency | Energy Saving Trust Best Practice Compliant | Specific Fan Power (W/l/s) | Heat Exchange Efficiency | Energy Saving Trust Best Practice Compliant |
| Kitchen + 1 Wet Room | 0.52 | 90% | Yes | 0.47 | 89% | Yes |
| Kitchen + 2 Wet Room | 0.59 | 89% | Yes | 0.54 | 88% | Yes |
| Kitchen + 3 Wet Room | 0.77 | 87% | Yes | 0.66 | 87% | Yes |
| Kitchen + 4 Wet Room | 1.00 | 86% | Yes | 0.85 | 87% | Yes |
| Kitchen + 5 Wet Room | 1.23 | 86% | Yes | 1.05 | 86% | Yes |

General Arrangement ▼

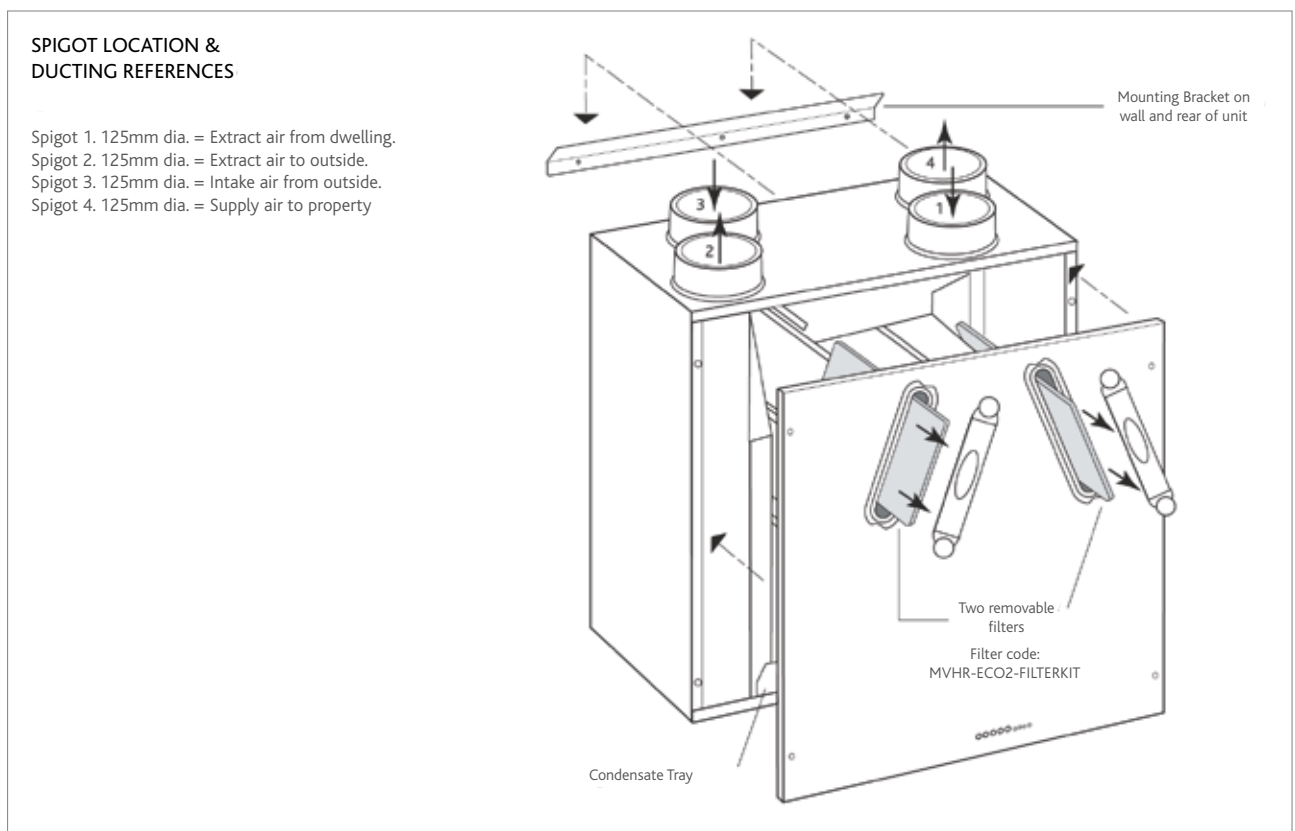

Technical - MRXBOX(AB)-ECO2 ▼

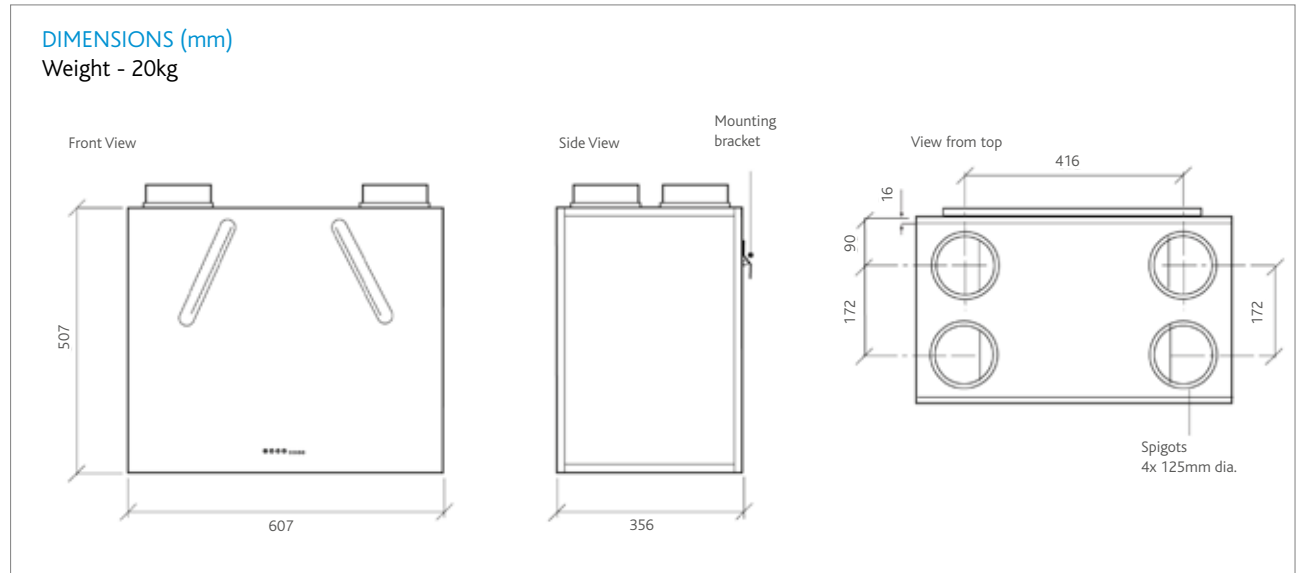

Electrical Details ▼

Please note: The electrical connection of the unit must be carried out by a qualified electrician.

The unit is supplied with a flexible cord for connection to the mains supply.

NOTE: This unit must be earthed.

The mains power supply cable should be connected to a fixed wiring installation in accordance with current IEE wiring regulations.

| | |
|-------------------------------------|---------------|
| Electrical Details: MRXBOX(AB)-ECO2 | |
| Voltage: | 230V 1ph 50Hz |
| Consumption: | 1.2 Amp |

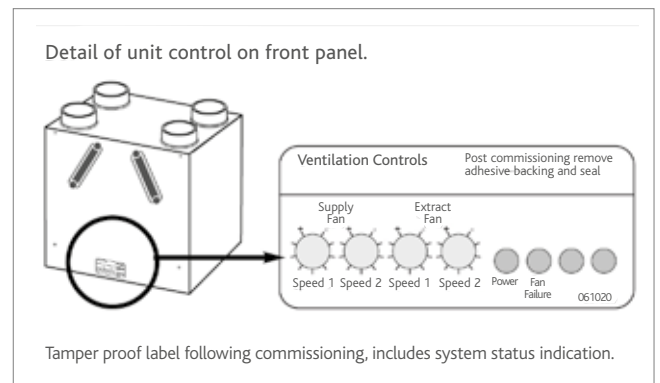

Wiring - MRXBOX(AB)-ECO2 ▼

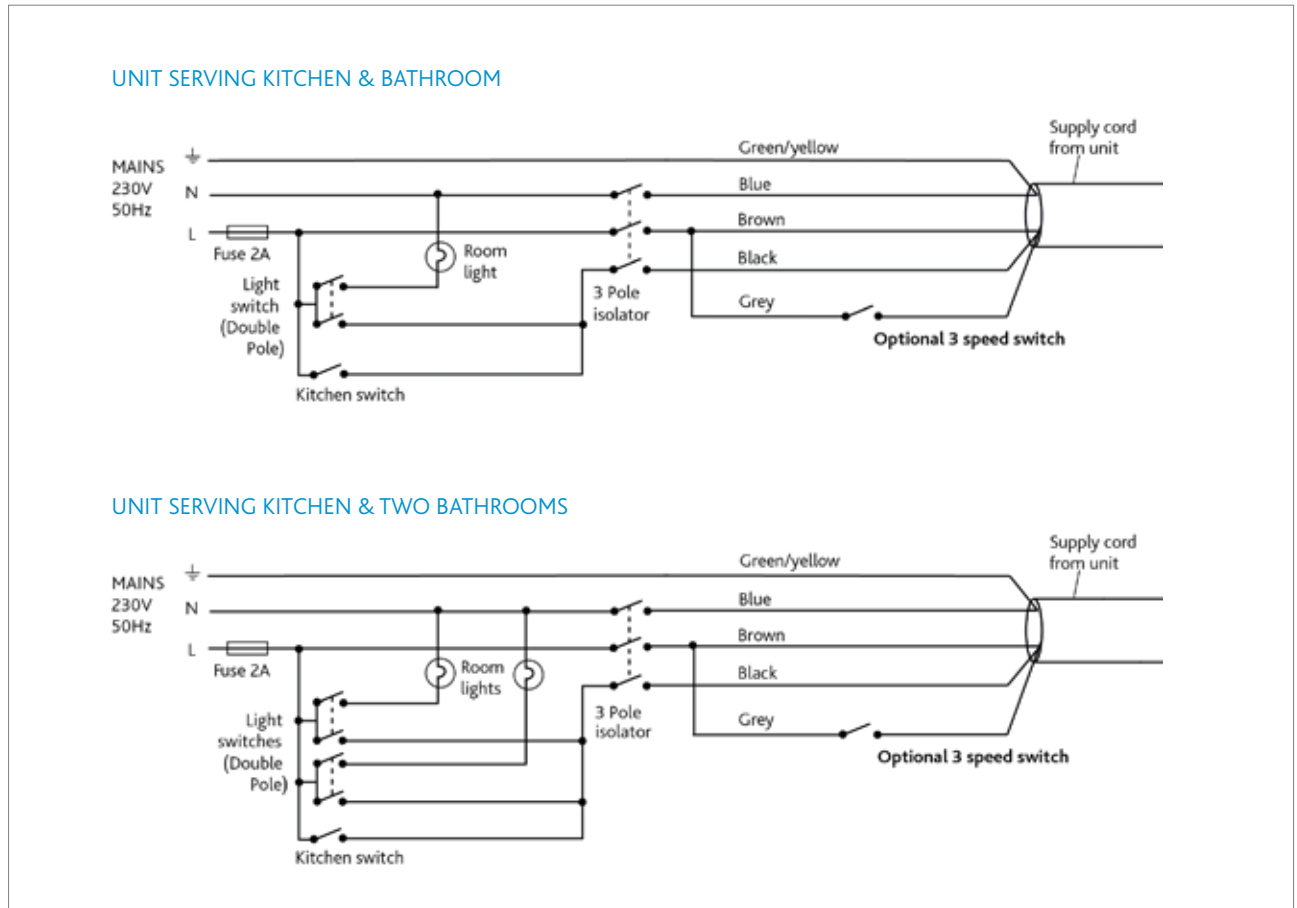

Optional Sensors and Detectors ▼

Customise MRXBOX(AB)-ECO2 for enhanced performance. All supplied with pre-plugged 10m data cable and incorporates status LED.

MRXBOX95-PIR (Passive Infrared)

A low voltage sensor, detects movement and activates system. Incorporates overrun timer and timer adjustments.

MRXBOX95-HUM (Relative Humidity)

A low voltage sensor, activates the system when the RH level is above set point. Incorporates overrun timer and RH setpoint level adjustment.

MRXBOX95-RFI (Remote Fail Indicator)

If fan failure occurs, the audio visual indicator will flash a warning.



MRXBOX-VSC
CONTROL SCREEN
COMPATIBLE WITH
THIS UNIT

Consultants Specification

SPECIFICATION

The unit shall be fully insulated providing excellent thermal and acoustic characteristics and shall be complete with a multi-plate, counter-flow, high-efficiency heat exchanger block, with a thermal efficiency of up to 95%. The heat exchanger shall be protected by G3 grade filters on fresh air inlet and system extract. The heat exchanger and filters shall be accessible via the front access panel, enabling quick and easy maintenance.

The unit shall have low energy, high-efficiency EC fan/motor assemblies with sealed for life bearings, the impellers shall be backward-curved centrifugal type. The motors shall be suitable for an ambient temperature of 40°C.

The unit shall be supplied complete with an insulated condensate drip tray and 21.5mm drain connection.

The unit shall be suitable for 125mm circular ducting.

Note: The unit is also available in opposite handed format, refer to spigot configuration for set up.

The breakout noise level and power requirements shall be as detailed by the unit manufacturer and in accordance with the ventilation equipment schedule.

Units shall be MRXBOX-ECO2 or MRXBOXAB-ECO2 as manufactured by Nuaire and shall be listed on the SAP PCDB.

MRXBOX-ECO2-OH and MRXBOXAB-ECO2-OH are opposite handed assemblies compliant as per standard handed versions listed in SAP PCDB.

OPERATION

The supply and extract system shall be positioned as indicated on the drawings and shall be in accordance with the particular fan schedule in the specification.

The combined supply and extract with heat recovery unit shall supply filtered fresh air to each of the habitable rooms and moisture-laden air shall be extracted from all wet areas, e.g. bathroom, en suite, w.c, kitchen, utility rooms etc. The supply air shall be pre-heated by the warm extract air via the integrated counter-flow heat exchanger element. The extracted air shall also be filtered before it reaches the heat exchanger block.

The ventilation unit shall vary its speed and therefore the ventilation rate, as it receives signals from one of the following:

- Switched live signal from light/remote switches.

When signals are received, the fan shall alter its speed to adjustable, normal and boost rates.

The unit shall have the facility to commission the supply and extract fans independently on minimum speed (continuous background ventilation) and boost speed via inbuilt minimum and maximum speed adjustment. The fans shall have infinitely variable speed control.

INTEGRAL AUTOMATIC HX BYPASS WITH NO REDUCTION IN AIRFLOW (MRXBOXAB-ECO2 & MRXBOXAB-ECO2-OH)

The bypass damper shall open automatically via a wax actuator, allowing the air to bypass the heat exchanger to deliver fresh filtered air during the warmer months.

The automatic bypass diverts 100% airflow around the heat exchanger with no reduction in airflow as independently tested by the BRE.

INTEGRAL HUMIDITY SENSOR (MRXBOXAB-ECO2 & MRXBOXAB-ECO2-OH)

The integral humidity sensor incorporated within the extract fan chamber will automatically boost both the extract and supply fan, to the commissioned boost speed, when the humidity level exceeds that set by the front panel mounted adjustment potentiometer.

CONTROL OPTIONS

All versions shall have the following functions integrally mounted within the fan unit on a purpose made PCB, all such components are pre-wired and factory fitted by the manufacturer:

- Independent control of background supply and extract flow rates.
- Independent control of boost speed supply and extract flow rates.
- Integral heat exchanger frost protection.
- Fan failure indication.
- Integral S/L terminal for boost from remote switch, e.g. light switch.
- Additional S/L terminal for 100% boost speed from remote switch, e.g. plate switch.
- Discreet daily run monitor.
- Remote fail indicator (part number MRXBOX95-RFI).
- Indication and controls – The unit shall have clear LED visual indication for maintenance, servicing and operation mode, i.e. HX bypass, frost protection.

MRXBOX-VSC (VISUAL SYSTEM CONTROLLER)

The MRXBOX-VSC is compatible with the Nuaire MRXBOXAB-ECO2 heat recovery units and can be purchased separately. The controller comes complete with commissioning and end user functions.

The display will be a 3.5" LCD display and will remain on standby until such time the screen is touched.

The initial display will show the MVHR system status as listed below:

- Current fan speed.
- Current indoor/outside temperature.
- Indicate when the Summer bypass is activated.
- Indicate when frost protection is activated.
- Indicate when the filters require cleaning/changing.

The unit shall come with a 5 year warranty which starts from the day of delivery, and includes parts and labour for the first year and parts only for the remaining 4 years.