

HIAQM

Haven Indoor Air Quality Filter Module Installation Manual



1.0 SAFETY INFORMATION

- The provision of the electrical supply and the connection of the unit to the electrical supply must be carried out by a qualified electrician.
- Isolate from power supply before removing any covers. During installation / maintenance ensure all covers are fitted before switching on the mains supply.
- All-pole disconnection from the mains as shown in the wiring diagram must be incorporated within the fixed wiring and shall have a minimum contact separation of 3mm in accordance with latest edition of the wiring regulations.
- Ducting must be securely fixed with screws to the spigot to prevent access to live parts. Duct runs terminating close to the fan must be adequately protected by suitable guards.
- This appliance should not be used by children or persons with reduced physical, sensory or mental capabilities or lack of experience and knowledge, unless they have been given supervision or instruction concerning the safe use of the appliance by a person responsible for their safety. Children shall not play with the appliance. Cleaning and user maintenance shall not be carried out by children.
- Carbon filters/pellets are not to be ingested, ensure hands are thoroughly washed after handling.

1.1 Symbols



GENERAL WARNING

Signifies a general warning regarding hazard specified by supplementary information.



ELECTRIC SHOCK

This unit must be completely electrically isolated before any panels are removed. Check mains supply and control connections.



REFER TO INSTRUCTION MANUAL

Read and understand the installation and maintenance manual before installing, operating or maintaining this product.

1.2 Important Information

This manual contains important information on the safe and appropriate assembly, transport, commissioning, operation, maintenance, disassembly and simple troubleshooting of the product.

While the product has been manufactured according to the accepted rules of current technology, there is still a danger of personal injury or damage to equipment if the following general safety instructions and the warnings contained in these instructions are not complied with.

- **Read these instructions completely and thoroughly before working with the product.**
- **Keep these instructions in a location where they are accessible to all users at all times.**
- **Always include the operating instructions when you pass the product on to third parties.**

1.3 Personal Protective Equipment

The following minimum Personal Protective Equipment (PPE) is recommended when interacting with Nuaire product:

- **Protective Steel Toed Shoes** - when handling heavy objects.
- **Full Finger Gloves (Marigold PU800 or equivalent)** - when handling sheet metal components.
- **Semi Fingerless Gloves (Marigold PU3000 3DO or equivalent)** - when conducting light work on the unit requiring tactile dexterity.
- **Safety Glasses** - when conducting any cleaning/cutting operation or exchanging filters.
- **Reusable Half Mask Respirators** - when replacing filters which have been in contact with normal room or environmental air.

Nuaire would always recommend a site specific risk assessment by a competent person to determine if any additional PPE is required.

2.0 INTRODUCTION

The Haven IAQ Module range of ancillaries has been specially designed to complement the existing commercial range of XBC+ units as well as providing a general function of high grade filtration to any commercial ventilation units which require it. The unit shall be manufactured from Alu-zinc with double skin panels filled with insulation to provide thermal and acoustic barriers. The units will come as standard with pressure monitoring for the filtration and give a relay output for alarm signalling when a pre-determined pressure value is exceeded. The units will be available with different access options (Bottom or Side access) as well as weatherproofing and coastal varieties depending on installation location. The unit is unhandled with different operations to suit it for different installations available in this literature. Further information regarding performance and specifications for the equipment may be obtained from our technical literature, and/or project specific documentation.

2.1 Code Description:

1	-	2	-	3	-	4	-	5	-	6	7
HIAQM	-	015	-	S	-	A	-	A	-	1	W

- 1. Range: **HIAQM** = Haven Indoor Air Quality Filter Module
- 2. Reference Flowrate:
 - 015** = 0.15m³/s
 - 025** = 0.26m³/s
 - 045** = 0.35m³/s
 - 055** = 0.48m³/s
 - 065** = 0.58m³/s
- 3. Access Type:
 - S** = Side Access
 - B** = Bottom Access
- 4. Primary Stage Filter: (Panel)
 - A** = G4 / ISO Coarse
 - B** = M5 / PM10 50%
 - C** = M6 / PM2.5 50%
 - D** = F7 / PM1 50%
 - E** = F8 / PM1 70%
 - F** = F9 / PM1 80%
 - H** = No Filter
- 5. Secondary Stage Filter: (Bag)
 - A** = G4 / ISO Coarse
 - B** = M5 / PM10 50%
 - C** = M6 / PM2.5 50%
 - D** = F7 / PM1 50%
 - E** = F8 / PM1 70%
 - F** = F9 / PM1 80%
 - G** = Rigid Carbon Panel Unit (RCP)
- 6. Unit Finish:
 - 1** = Standard
 - 4** = Coastal (C4*)
- 7. Unit Roof:
 - 1** = Standard Unit (No Roof)
 - W** = Twin Pitched Roof (Factory Fitted)

* This units coastal finish has been designed to withstand an External C4 Atmospheric Corrosivity Category as per BS EN ISO 12944-2:2017 providing that it is installed and maintained as per the manufacturer's instructions and general Warranty Guidance Notes found in our conditions of sale.

2.2 Dimensions & Weight

2.2.1 Standard Side Access Unit (e.g. HIAQM-015-S-A-A-11)

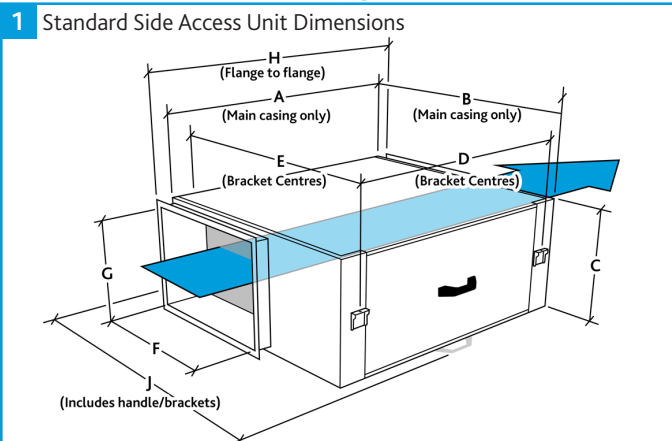

2.2.2 Standard Bottom Access Unit (e.g. HIAQM-015-B-A-A-11)

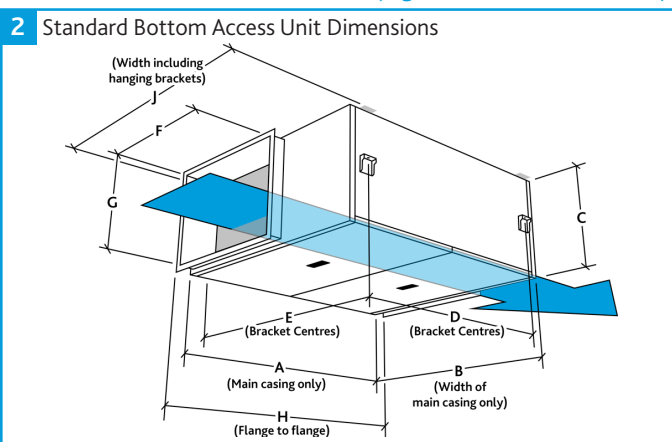

Unit Size	Side / Bottom			Hanging Bracket		Flange Connector		Length	Side Access Units	Bottom Access Unit
	A	B	C	D	E	F	G			
IAQM-015	890	665	259	755	690	351	218	1010	728	709
IAQM-025	990	809	339	855	830	481	298	1110	869	849
IAQM-045	990	885	399	855	907	536	358	1110	945	925
IAQM-055	990	1068	469	855	1090	592	428	1110	1128	1108
IAQM-065	890	1068	622	755	1090	592	578	1010	1128	1108

2.2.3 Twin Pitched Roof Unit (e.g. HIAQM-015-S-A-A-1W)

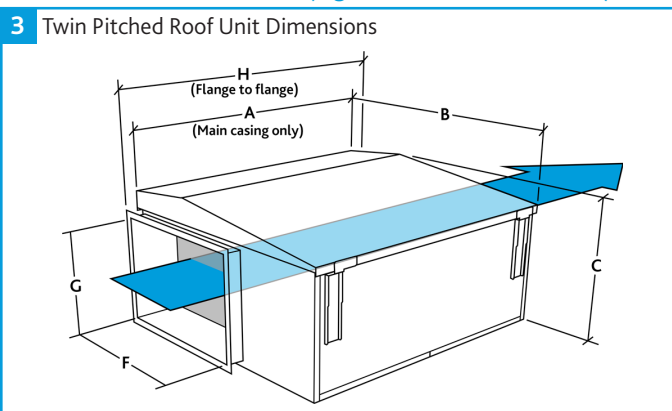

Unit Size	Side / Bottom			Flange Connector		Length	Width
	A	B	C	F	G		
IAQM-015	902	695	334	351	218	1010	729
IAQM-025	1002	839	424	481	298	1110	870
IAQM-045	1002	915	489	536	358	1110	946
IAQM-055	1002	1098	574	592	428	1110	1129
IAQM-065	902	1098	727	592	578	1010	1129

2.3 Delivery of Equipment

2.3.1 Receipt of Equipment

All equipment is inspected prior to despatch and leaves the factory in good condition. Upon receipt of the equipment an inspection should be made and any damage indicated on the delivery note.

Particulars of damage and/or incomplete delivery should be endorsed by the driver delivering the goods before offloading by the purchaser. No responsibility will be accepted for damage sustained during the offloading from the vehicle or on the site thereafter. All claims for damage and/or incomplete delivery must be reported to Nuair within two days of receipt of the equipment following guidance in our terms & conditions of sale.

2.3.2 Offloading and Handling

The weight of the unit modules and palletised items is displayed on the unit rating plate or on the packaging. Some of the modules have an uneven weight distribution, and this will be indicated by labelling where appropriate. Ensure that lifting and handling equipment is adequately rated. Offloading and positioning of the equipment is the responsibility of the purchaser.

Spreaders should be used when lifting with slings to avoid damage to the casings. Care must be taken to ensure that slings are correctly positioned to avoid crushing and twisting of the unit castings.

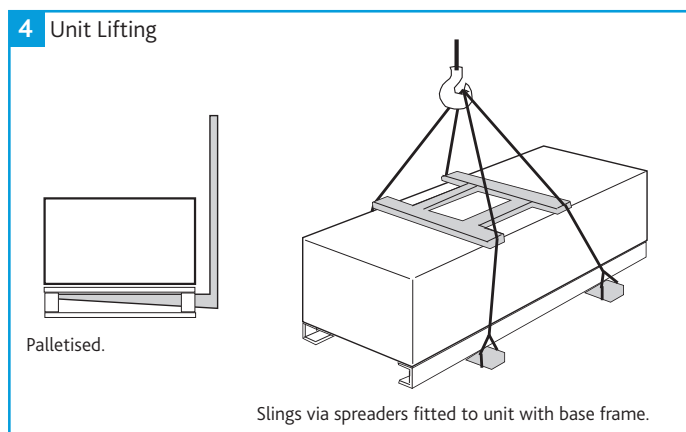

3.0 MECHANICAL INSTALLATION

Installation of the IAQ modules, including all external services and controls should be in accordance with the appropriate authority and MUST conform to all governing regulations e.g. CDM, CIBSE, IEE, and in strict accordance with the applicable Building Regulations. These units may only be mounted horizontally.

The correct installation position for the units shall be decided with due regard to access and maintenance requirements, and the objective of minimising the system ductwork resistance.

The units are heavy, and should be mounted using the fixing brackets supplied or other suitable methods of support. The supporting structure must be assessed for structural suitability.

The recommended installation method is to use standard Unistrut channel secured to the slab / steelwork above the unit.

Four suitable drop rods should be secured to the Unistrut channel and extended to be fixed to the unit's four mounting brackets (two each side of the unit), or to other horizontal supports by others where wider load distribution is required.

3.1 IAQM Layout Modifications

Depending on the installation requirements of the IAQM unit (e.g. location, orientation, model variant, etc.), onsite modifications of the module may be needed. Refer to the table provided for modification requirements.

Fan Unit Attachment Method	Access Type	HIAQM Roof	XBC Unit Handing	Required IAQM Layout Modifications
Ducted	Side	No	N/A	None.
Ducted	Side	Yes	N/A	None.
Ducted	Bottom	No	N/A	None.
Close Coupled	Side	No	Left	Attach XBC Flange.
Close Coupled	Side	No	Right	Attach XBC Flange, Roll IAQM Unit.
Close Coupled	Side	Yes	Left	Attach XBC Flange, Relocate IAQM Roof,
Close Coupled	Side	Yes	Right	Attach XBC Flange, Roll IAQM Unit, Relocate IAQM Roof.
Close Coupled	Bottom	No	Left	Attach XBC Flange.
Close Coupled	Bottom	No	Right	Switch Spigot Plates, Attach XBC Flange.

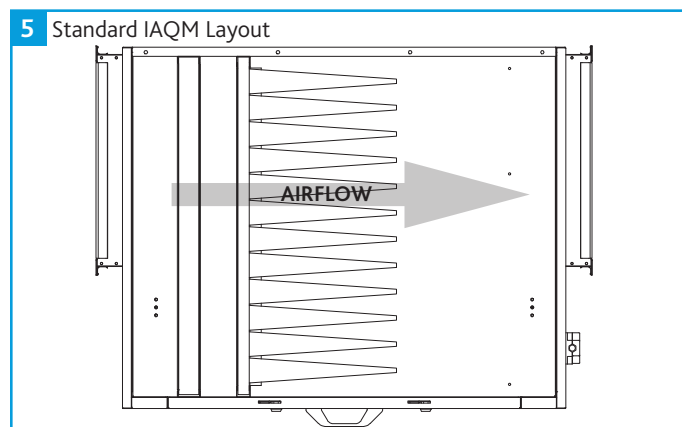

3.1.1 Switching Spigot Plates

If bottom access IAQM unit is to be close coupled to a right hand configuration XBC unit, the IAQM unit inlet and outlet spigot plates must be switched to ensure XBC ducting paths are clear. Detach both IAQM spigot plates by removing the bolts securing the plate to the IAQM unit. Exchange the inlet and outlet spigot plates and reattach to the IAQM using the same bolts and fixing points.

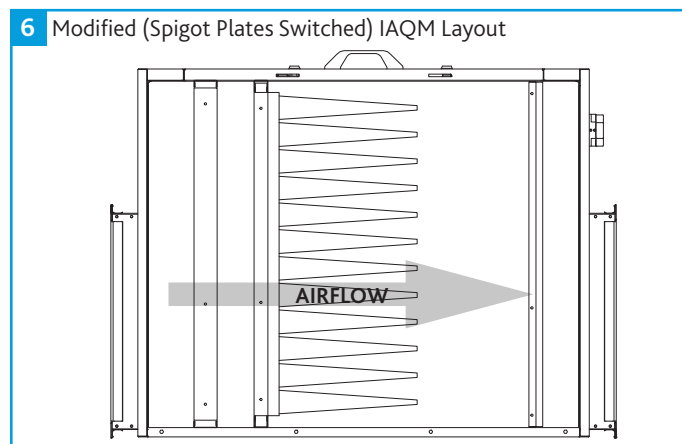

3.1.2 Attaching XBC Flange

To aid in installation where IAQM units are to be close coupled to a matching size XBC unit, the double (Supply & Extract) flange connector of the XBC unit should be removed from the XBC and fitted to the IAQM unit's inlet along with the extract leg ducting. The full assembly of IAQM unit, XBC flange connector and extract ducting can then be raised and connected to the XBC unit. For further details see "Flange Connector Dimensions (mm)" section, located in XBC+ installation manual provided with XBC+ units.

7 HIAQM Connected to XBC+ Unit

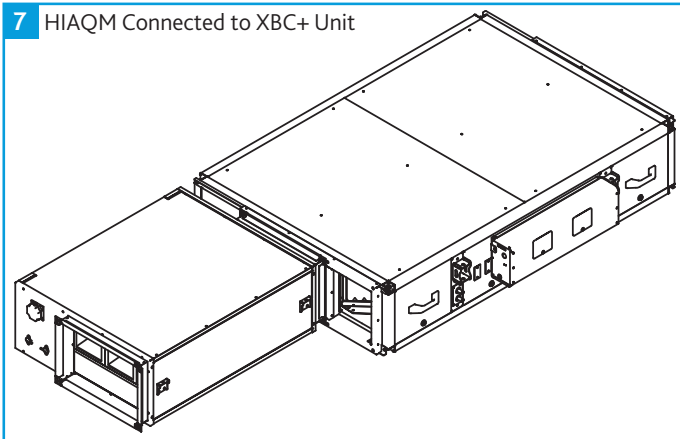

3.1.3 Rolling IAQM Unit

If a side access IAQM unit is to be close coupled to a right hand configuration XBC unit, roll the IAQM unit 180° to ensure XBC ducting paths are clear.

Where a roof is supplied with the IAQM the roof should be removed by unscrewing the 4x roof mounting points (2x M8 hex bolts) before rolling the unit and reattaching the roof using the same 4 roof mounting points.

Where an IAQM has no roof, the 4x mounting brackets provided can be also be removed (2x M8 hex bolts) and reattached according to the required mounting method if needed.

8 Handling IAQM Unit

Roll IAQM 180°

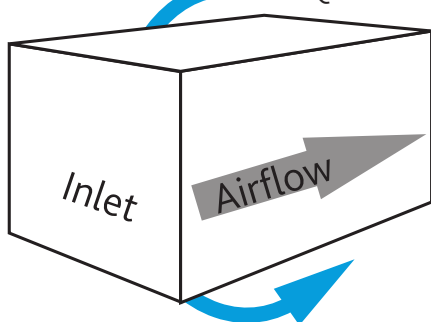

3.1.4 Relocating IAQM Roof

Due to the XBC roof overhang, an IAQM with roof cannot be close coupled to an XBC unit with roof without relocating the IAQM roof prior to installation.

Unscrew the M8 hex bolts attaching the IAQM roof to the 1st and 2nd roof fixing points. Slide the IAQM roof away from the IAQM inlet and utilize the 2nd and 3rd roof fixing point to reattach the IAQM roof.

9 Standard Ducted IAQM With Roof

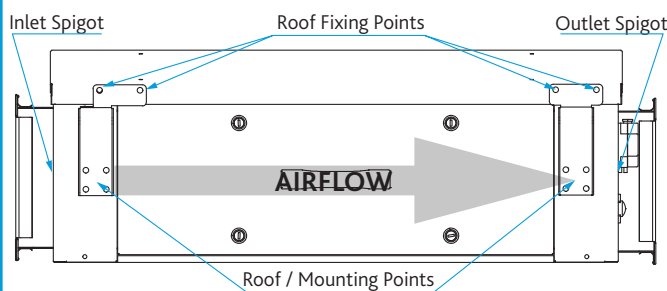

10 Close Coupled IAQM With Modified (Relocated) Roof

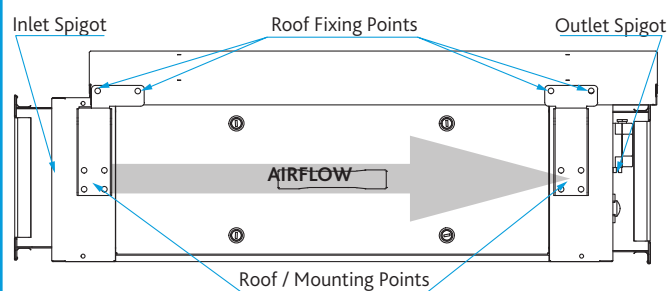

3.2 Dirty Filter Pressure Switch

Isolate from power supply before removing any covers. During installation / maintenance ensure all covers are fitted before switching on the mains supply.

Replacement Pressure switches are available if needed (HAVEN-PDIFF).

11 Dirty Filter Switch Details

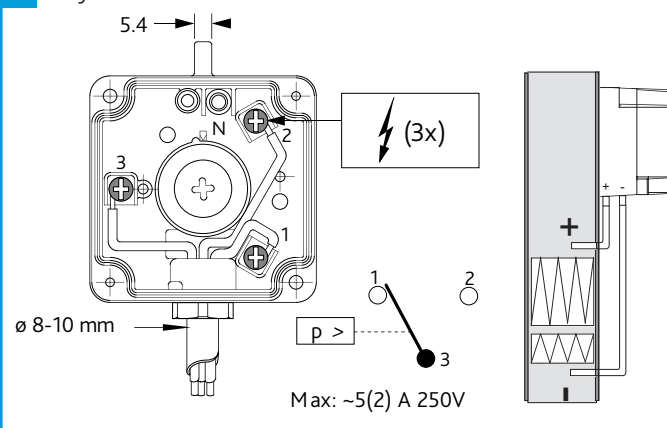

3.2.1 Dirty Filter Pressure Switch Wiring

The cable gland is designed for cables with alternative sheath diameters of 8 - 10 mm. Only use these sizes, otherwise the screw cable connection cannot seal adequately. The connections are intended for 6.3mm crimp-type sockets.

- Remove switch cover.
- Wire the main unit to the terminal block within the switch as per the below wiring diagrams (Figure 12) ensuring the feed line is fused to suit Max 1.5A / 250 Vac.

•Refit switch cover.

acting immediately to treat/restore any damaged areas.

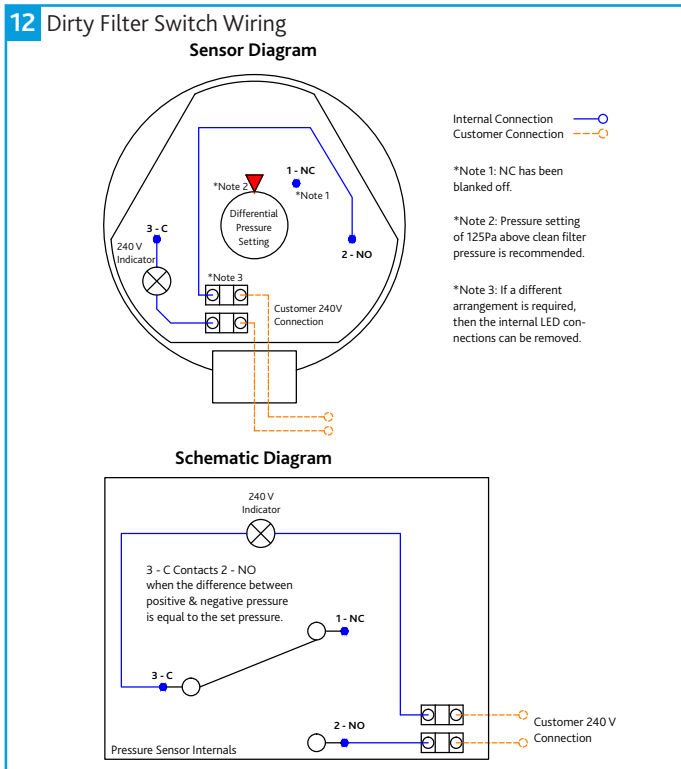

4.5 Replacement Filters

To check the filter type within a unit refer to the module product label. Replacement filters can be purchased direct from Nuair using the below code format.

1	-	2	-	3	4	-	5
HIAQM	-	015	-	1	D	-	FILTER

- 1. Range: **HIAQM** = Haven Indoor Air Quality Filter Module
- 2. Reference Flowrate:
 - 015** = 0.15m³/s
 - 025** = 0.26m³/s
 - 045** = 0.35m³/s
 - 055** = 0.48m³/s
 - 065** = 0.58m³/s
- 3. Filter Position:
 - 1** = Primary Panel Filter
 - 2** = Secondary Bag Filter
- 4. Filter Grade:
 - A** = G4 / ISO Coarse
 - B** = M5 / PM10 50%
 - C** = M6 / PM2.5 50%
 - D** = F7 / PM1 50%
 - E** = F8 / PM1 70%
 - F** = F9 / PM1 80%
 - G** = Rigid Carbon Panel Unit (RCP)

For reference on the filter type required please refer to the module product label e.g. The codes required to order both filters of a **HIAQM-025-S-D-G-11** would be:

HIAQM-015-1D-FILTER
HIAQM-015-2G-FILTER

5.0 WARRANTY

The 5 year warranty starts from the day of delivery and includes parts and labour for the first year. The remaining period covers replacement parts only (replacement filters not included).

This warranty is void if the equipment is modified without authorisation, is incorrectly applied, misused, disassembled, or not installed, commissioned and maintained in accordance with the details contained in this manual and general good practice.

The product warranty applies to the UK mainland and in accordance with Clause 14 of our Conditions of Sale. Customers purchasing from outside of the UK should contact Nuair International Sales office for further details.

Failure to maintain the unit as recommended will invalidate the

3.2.2 Setting Dirty Filter Switch Pressure

Nuair recommend the pressure switch be set to trigger when the filters experience a 125 Pa increase above the clean filter resistance for the largest commissioned airflow rate. Use the adjustment dial to set the pressure at which the switch will trip. When the pressure falls below this set value, the switch returns to its resting position.

4.0 MAINTENANCE

It is important that maintenance checks are recorded and that the schedule is always adhered to, in all cases, the previous report should be referred to.

4.1 Carbon Filter Maintenance

After a period of time, activated carbon in filter cells will become saturated by odour, gas and chemical vapour contaminants and will require replacement in order to maintain the filtration efficiency of the carbon filter. HIAQM Carbon Filters have a lifespan of 2 years under normal conditions. However, under certain circumstances, such as highly polluted air, carbon filters may need to be replaced on a more frequent basis. Contact Nuair for accurate assessments of carbon filter lifespans.

4.2 Routine Maintenance

- Clean all areas of unit and treat any areas of corrosion.
- Check all access doors for leakage and if necessary locks should be adjusted and any replacement gasket materials should be replaced as required.

4.3 Every 3 Months

- Check filters and change/clean if required, failure to do so may impair the performance and energy efficiency of this unit.

4.4 Annually

- Thoroughly inspect the unit and its components for corrosion,

warranty.

6.0 END-OF-LIFE AND RECYCLING

Where possible Nuair use components which can be largely recycled when the product reaches its end-of-life:

- Fans, motors, controls, actuators, cabling and other electrical components can be segregated into WEEE recycling streams.
- Sheet metal parts, aluminium extrusion, heating/cooling coils and other metallic items can be segregated and fully recycled.
- EPP, plastic ducting, nylon corner pieces, plastic heat exchangers, packaging material and other plastic components can be segregated into mixed plastic and widely recycled.
- Cardboard packaging, wood, used filters and other paper components can be largely recycled or fully processed in energy from waste centres.
- Remaining Items can be further segregated and processed in accordance with the zero waste hierarchy. Please call After Sales Support for further information on items not listed above.

Ensure that Nuair product is made safe from any electrical / water / refrigerant supplies before dismantling commences. This work should only be undertaken by a qualified person in accordance with local authority regulations and guidelines, taking into account all site based risks.

7.0 AFTER SALES AND REPLACEMENT PARTS

For technical assistance or further product information, including spare parts and replacement components, please contact the After Sales Department.

If ordering spares please quote the serial number of the unit together with the part number, if the part number is not known please give a full description of the part required. The serial number will be found on the identification plate attached to the unit casing.

Telephone 02920 858 400
aftersales@nuaire.co.uk

