



NEPTUNE T-CO

Thermal Wheel AHU with
Connect (CO) Control
Installation Manual



1.0 SAFETY INFORMATION

- The provision of the electrical supply and the connection of the unit to the mains must be carried out by a qualified electrician.
- Isolate from power supply before removing any covers. During installation / maintenance ensure all covers are fitted before switching on the mains supply.
- All-pole disconnection from the mains as shown in the wiring diagram must be incorporated within the fixed wiring and shall have a minimum contact separation of 3mm in accordance with latest edition of the wiring regulations.
- This unit must be earthed.
- Ducting must be securely fixed with screws to the spigot to prevent access to live parts. Duct runs terminating close to the fan must be adequately protected by suitable guards.
- If the supply cord is damaged, it must be replaced by the manufacturer, its service agent or similarly qualified persons in order to avoid a hazard.
- Precautions must be taken to avoid the back-flow of gases into the room from the open flue of gas or other fuel-burning appliances.
- This appliance should not be used by children or persons with reduced physical, sensory or mental capabilities or lack of experience and knowledge, unless they have been given supervision or instruction concerning the safe use of the appliance by a person responsible for their safety. Children shall not play with the appliance. Cleaning and user maintenance shall not be carried out by children.

1.1 Symbols



GENERAL WARNING

Signifies a general warning regarding hazard specified by supplementary information.



ELECTRIC SHOCK

This unit must be completely electrically isolated before any panels are removed. Check mains supply and control connections.



ROTATING PARTS

This unit contains fast moving rotational parts which may start automatically. It is the sole responsibility of the installer to adequately guard these components.



REFER TO INSTRUCTION MANUAL

Read and understand the installation and maintenance manual before installing, operating or maintaining this product.

1.2 Important Information

This manual contains important information on the safe and appropriate assembly, transport, commissioning, operation, maintenance, disassembly and simple troubleshooting of the product.

While the product has been manufactured according to the accepted rules of current technology, there is still a danger of personal injury or damage to equipment if the following general safety instructions and the warnings contained in these instructions are not complied with.

- **Read these instructions completely and thoroughly before working with the product.**
- **Keep these instructions in a location where they are accessible to all users at all times.**
- **Always include the operating instructions when you pass the product on to third parties.**

1.3 Personal Protective Equipment

The following minimum Personal Protective Equipment (PPE) is recommended when interacting with Nuaire products:

- **Protective Steel Toed Shoes** - when handling heavy objects.
- **Full Finger Gloves (Marigold PU800 or equivalent)** - when handling sheet metal components.
- **Semi Fingerless Gloves (Marigold PU3000 3DO or equivalent)** - when conducting light work on the unit requiring tactile dexterity.
- **Safety Glasses** - when conducting any cleaning/cutting operation or exchanging filters.
- **Reusable Half Mask Respirators** - when replacing filters which have been in contact with normal room or environmental air.

Nuaire would always recommend a site specific risk assessment by a competent person to determine if any additional PPE is required.

2.0 INTRODUCTION

The packaged supply and extract unit shall be manufactured from Aluzinc corrosion resistant steel, with 50mm double skinned panels and anodized aluminium frame. All external fittings and fixings shall be stainless steel, aluminium or non-metallic. All panels and frames will be of a totally thermally broken design, complying with the following specification in accordance with BS EN 1886: Mechanical strength, D1; Leakage class, L2; Thermal transmittance, T3; Thermal bridging, TB3. Panels and frames will be sealed without the use of silicon, mastic or other liquid gasket.

An ERP compliant heat exchanger with automatic bypass, complete with a condensate tray (where cooling is fitted) included. An F7 main supply filter shall be fitted with an M5 filter bank present on the extract side. Rails for an additional supply G4 panel filter shall be present with pressure drop monitoring for maintenance notification included.

Performance optimised backward curved impellers and IP54 EC motors shall be used to provide low specific fan powers and step less speed control without tonal noise generation. Fan pressure transducers shall be fitted (Connect control only) for constant pressure/ flow control and energy monitoring.

All hinged access panels shall be lockable and removable (with a common key for all) allowing full maintenance access from the side. The unit has left (and right option) hand arrangement in direction of supply air flow.

A LPHW heater battery shall be fitted (on LPHW units). An electric heater module shall be present (on Electric heater units), complete with power controller to allow output modulation from the unit control. A fail-safe auto-reset safety device shall be present.

Structural base frames shall be fitted, powder coated with covered forklift slots and 50mm square lifting bar holes for site manoeuvrability. Three axis alignment clamps shall be fitted externally.

An IP66/67 lockable isolator shall be present for power connection on main and electric heater modules. Sealing grommets will be present for control cable access to the unit internals without the need for drilling on site. Module electrical interconnection shall be made using pre-fitted plug and socket arrangements.

Modules shall be provided with identification labelling to aid assembly and QR coded badges to simplify document retrieval via portable devices.

Autodesk REVIT files shall be provided for Building Information Modelling and all units shall be based on performance testing carried out within an AMCA certified test laboratory.

2.1 Code Description:

N	07	T	/	L	R	/	CO	-	L	WP	4
1	2	3	/	4	5	/	6	-	7	8	9

1. Range: **N** = Neptune AHU
2. Unit Size: **07, 12, 17, 22, 32, 42** or **55**
3. Heat Recovery Type: **T** = Thermal Wheel
4. Heating Type: **E** = Electric (07 - 42 Only)
L = Low Pressure Hot Water (LPHW)
N = No Heating
- Cooling Type: **C** = Chilled Water (CW)
N = No Cooling
X = Reverse Cycle DX (condenser unit and controls by others)
5. Control Type: **CO** = Connect
6. Access Handing (in direction of supply airflow) **L** = Left Hand
R = Right Hand
7. Unit Roof: **No Affix** = Standard Unit (No Roof)
WP = Roof (Factory Fitted)
8. Unit Finish: **No Suffix** = Standard
4 = Coastal (C4**)

** This units coastal finish has been designed to withstand an External C4 Atmospheric Corrosivity Category as per BS EN ISO 12944-2:2017 providing that it is installed and maintained as per the manufacturer's instructions and general Warranty Guidance Notes found in our conditions of sale.

3.0 DELIVERY & RECEIPT OF EQUIPMENT

All equipment is inspected prior to despatch and leaves the factory in good condition. Upon receipt of the equipment an inspection should be made and any damage indicated on the delivery note.

Particulars of damage and/or incomplete delivery should be endorsed by the driver delivering the goods before offloading by the purchaser.

No responsibility will be accepted for damage sustained during the offloading from the vehicle or on the site thereafter.

All claims for damage and/or incomplete delivery must be reported to Nuair within two days of receipt of the equipment.

3.1 Unit Offloading and Handling

The weight of unit modules and palletised items is displayed on the packaging. Some of the modules have an uneven weight distribution and this will be indicated by labelling where appropriate.

Offloading and positioning of the equipment is the responsibility of the purchaser, and should only be performed by competent personnel following an appropriate risk assessment.

To ensure that the delivery vehicle is loaded according to the planned method of offloading, Nuair must be notified to ensure coordination. When offloading, care must be taken to ensure that the AHU is kept level at all times.

To ensure that no roof damage occurs additional timber packaging must be used.

3.2 Base Frame Lifting Points

Only individual modules should be lifted or manoeuvred. The units must not be lifted or manoeuvred pre-assembled.

When units are constructed of multiple modules each module will have it's own individual base frame, which is then connected to the next to assemble the full system.

All base frame sections will have 50mm square lifting holes at the end of each side to enable lifting. In addition to this, covered fork lifting channels are located across the width of the base frame, if the module length is sufficient to allow this. For shorter modules the fork lifting points will be along the length of the section, without a covered channel (Figure 2).

1 Typical Methods of Lifting

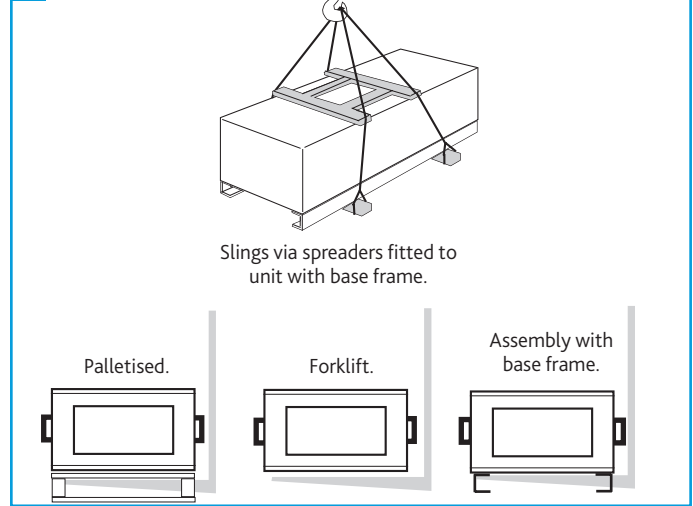

3.3 Unit Packaging

Unless otherwise specified, unit sections will be delivered to site covered in "shrink wrap" polythene, which should provide a more than adequate level of protection against inclement weather.

Should alternative methods of unit protection be required (i.e. timber, Corex, or flame retardant materials), Nuair Limited should be notified of the specific requirements at the pre- contract stage. Waste must be disposed of by a registered waste carrier in accordance to national regulations.

3.4 Unit Storage

The equipment must be stored in a dry, internal location. Ductwork connection apertures should be sealed against the ingress of dust, water and vermin. Note that units that are intended for external locations are generally not fully weatherproofed until their installation, including ductwork connections, is complete.

If the storage period is to exceed two months, contact Nuair for guidance on the appropriate 'mothballing' procedures. Do not stack units, modules or components.

2 Base Frame Detail

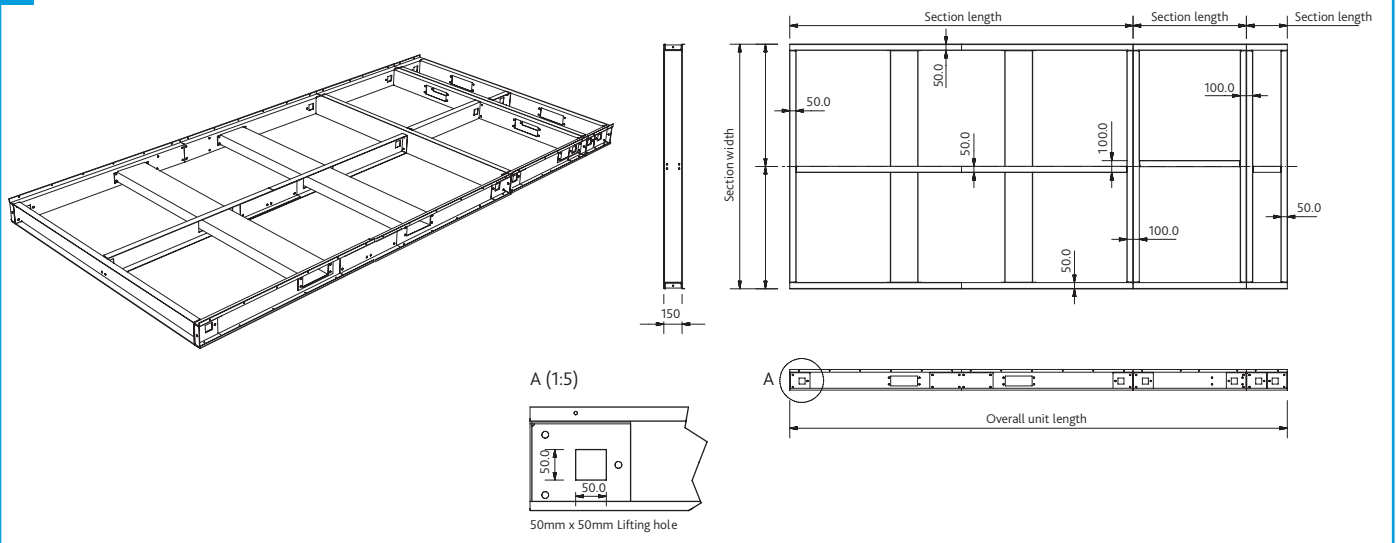

4.0 MECHANICAL INSTALLATION

Installation must be completed by competent persons, in accordance with good industry practice and should conform to all governing and statutory bodies i.e. IEE, CIBSE, etc.

The unit should stand upright and level on the floor, foundation or supporting steelwork which should be rigid, flat and level and should be capable of supporting the weight of the unit including water or refrigerant in the coils. Nuair takes no responsibility for the coordination of support.

4.1 Unit Location

To prevent possible reintroduction of contaminated air through the outside air intake, the unit should be located away from building flue stacks or exhaust ventilators.

Once assembled and in position, sufficient free space must be available adjacent to the unit for future inspection, maintenance, component service, repair and replacement and connection of services. It is recommended that at least the unit width (vertically arranged units) + 100mm be allowed. A minimum of 600mm is required for regular maintenance.

4.2 Air Leakage

Loading, transportation, off loading and site positioning can cause the air handling unit structures to move, therefore panel seals will not always remain fully intact.

It is inevitable that in such cases, re-sealing of the units panels and joints may have to be carried out on site for the air-handling units to achieve the required leakage classification. Door locking mechanisms may also have to be adjusted.

Nuair cannot be held responsible for the units failing a site leakage test if the above have not been carried out correctly.

4.3 Module Joints

After unwrapping, temporarily remove the rubber weatherproof cover strip and M10 base frame bolts from any modules and store in a safe location for later use.

Apply the sealing gasket as necessary to the mating faces of the unit frames. Typically the sealing gaskets are pre-fitted to the heat exchanger module; ancillary modules will be provided with a roll of sealing gasket for on-site fitting.

Make the unit joints in the following order:

- Left and right hand side M10 bolts between the modules' base frames (Figure 3).
- Left and right hand side M6 Lower 3 axis alignment clamps (Figure 4).
- Left and right hand side M6 Middle 3 axis alignment clamps.
- Left and right hand side M6 Upper 3 axis alignment clamps.

Air leakage, air blow marks to the unit casings and unacceptable noise levels could result if the correct installation procedures are not employed.

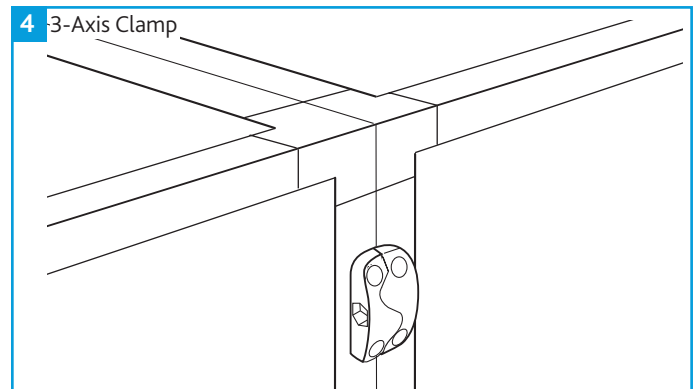
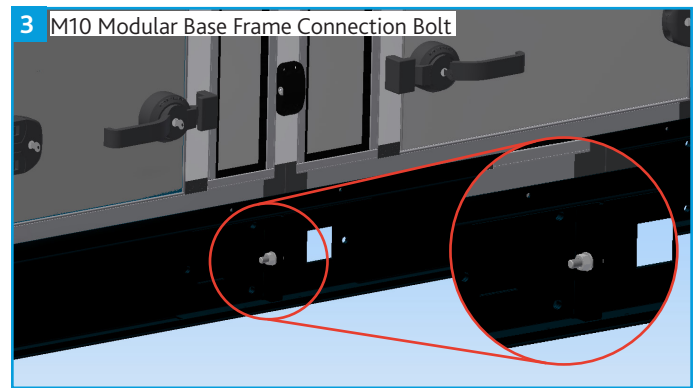

4.4 Internal Connections

There are a number of internal connections that need to be completed prior to starting/commissioning the unit. These consist of all the wiring connections and the condensate hose (plate heat exchanger option only).

Please ensure that the condensate hose is connected between modules. Care must be taken to ensure a constant fall in gradient is maintained and the hose is kept taut (Figure 5).

Access is available in the fan plate to allow electrical/wiring connections to be made between modules (Figure 5).

When making the wiring connections, the sensor loop (Figure 6) must be removed and relocated to the end of the unit.

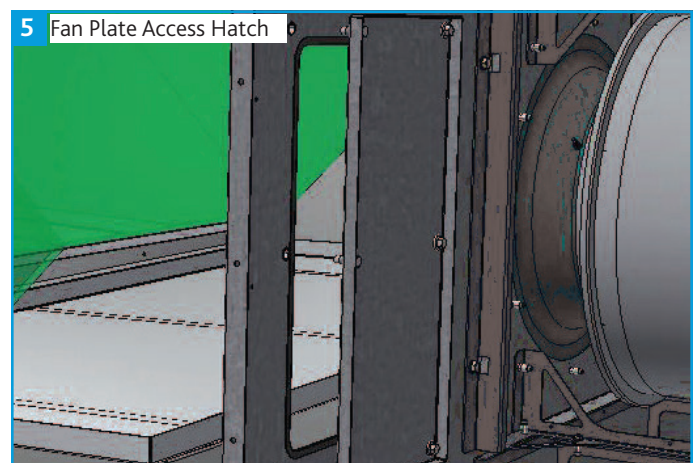

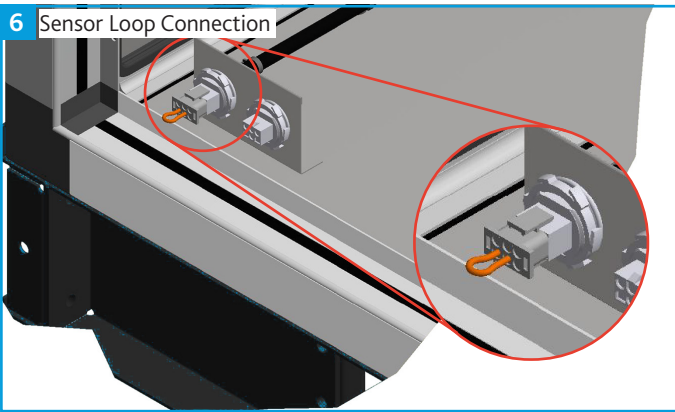

4.7 Weather Resistant Units

The units are supplied in multiple sections and have weather resistant roof components that must be fitted and sealed after the unit sections are bolted together. All necessary fixings are supplied with each unit and are normally bagged and located within the fan section. Suitable mastic sealant is to be provided by others.

Where the weatherproof roof assembly of two sections meet, the metal hinged weatherproof cover strip must be closed to seal the seam between unit sections and fixed with the bolts provided.

The equipment must not be exposed to the weather in an unassembled or partially assembled state. All roof terminal, ductwork, sealing and assembly work must be completed before the unit can be considered weather resistant.

4.8 Unit Connections

4.8.1 Ducting

Nuair do not provide ductwork connections with units, instead the open ended framework should be utilised. Flanged connections are available as an option, refer to technical documents for information relating specifically to the manufactured unit.

4.8.2 Coil

If a frost coil is not fitted then appropriate control methods must be taken to prevent the coils, filters and other equipment from freezing (by others).

When connecting coils, special care is needed to allow for expansion and contractions. Prior to any equalising connection, ensure that the thermostatic expansion valve for the DX coil is securely fitted.

Additional care must be taken when using R32 or other flammable refrigerants: your commissioned system must comply with the requirements of BS EN 378. Units must be fitted with gas detection systems (or deploy other suitable control method) to ensure that, in the event of a refrigerant leak, the Lower Flammability Limit is not exceeded.

Unit Size	Frost Coil (LPHW)		Heating Coil (LPHW)		Cooling Coil (CHW)	
	Flow	Return	Flow	Return	Flow	Return
07	22 mm	22 mm	35 mm	35 mm	28 mm	28 mm
12	28 mm	28 mm	35 mm	35 mm	28 mm	28 mm
17	28 mm	28 mm	35 mm	35 mm	35 mm	35 mm
22	28 mm	28 mm	35 mm	35 mm	35 mm	35 mm
32	35 mm	35 mm	54 mm	54 mm	42 mm	42 mm
42	35 mm	35 mm	42 mm	42 mm	42 mm	42 mm
55	42 mm	42 mm	42 mm	42 mm	54 mm	54 mm

Each coil section should be trapped and special care should be taken to ensure that there are no vertical rising condense lines, unless pumped. Wet pipe connections sizes are listed in the table below.

Care should be taken to ensure that all pipework is adequately supported, therefore ensuring that no additional weight is added to the unit. Extra precaution should be taken to prevent pipe damage on site, as the fragile pipework will protrude from the side of the unit.

4.5 Condensate Drain

Sufficient clearance for U-traps on condensate drain and overflow connections should also be considered by the purchaser.

Plate heat exchanger components and modules that incorporate cooling coils may produce condensation during use. An insulated drip tray is provided where necessary. The drain connection must be connected to a suitable drainage point.

Provision may be required, and if so, should be made, for the fitting of a correctly sized cleanable trap to each drain connection.

4.5.1 Under Negative Pressure

If the condensate tray is located at the inlet side of the fan (i.e. under negative pressure) then calculate the values of A & B as shown below.

A = Fan inlet pressure (mm H₂O, 10Pa = 1mm H₂O) +25mm (minimum). Allow 100mm for these units if pressure is unknown.

B = A/2 (minimum).

4.5.2 Under Positive Pressure

If the condensate tray is located at the outlet side of the fan (i.e. under positive pressure) then calculate the values of A & B as shown below.

A = 25mm (minimum).

B = Fan outlet pressure (mm H₂O, 10Pa = 1mm H₂O) +25mm (minimum). Allow 100mm for these units if pressure is unknown.

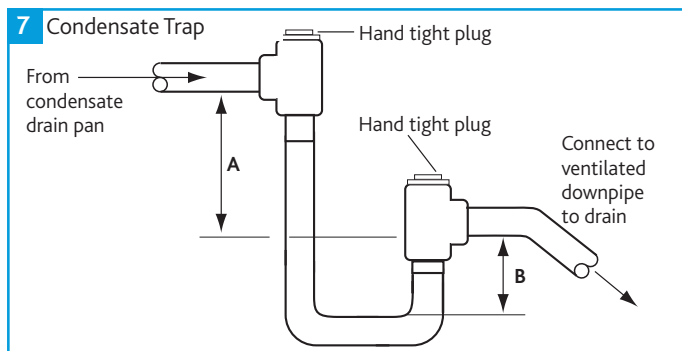

4.6 Thermal Wheel Drive / Belt Tension

Thermal wheel modules can be delivered with transport packing blocks, ensure any transport blocks are removed prior to operation of the thermal wheel.

The thermal wheel belt is unhooked to prevent the thermal wheel belt from stretching during transportation.

The thermal wheel motor is attached via a hanging motor bracket. To install the belt lift the spring motor upwards, hook the belt onto the pulley and slowly release the motor.

Ensure that the rotation sensor is aligned with the sensing studs, as this can become misaligned during transport/installation thus causing a fault signal.

4.9 Filters

4.9.1 Filter Removal

Filters will be provided in banks on suitable slide rails, so that they can be withdrawn from the access side of the unit. Differential "Dirty Filter" pressure switches are fitted as standard.

4.9.2 Spare Filters

If specified with order, spare sets of filters will be provided and should be stored in a clean, dry environment. Should you require spare filter media, please contact Nuair.

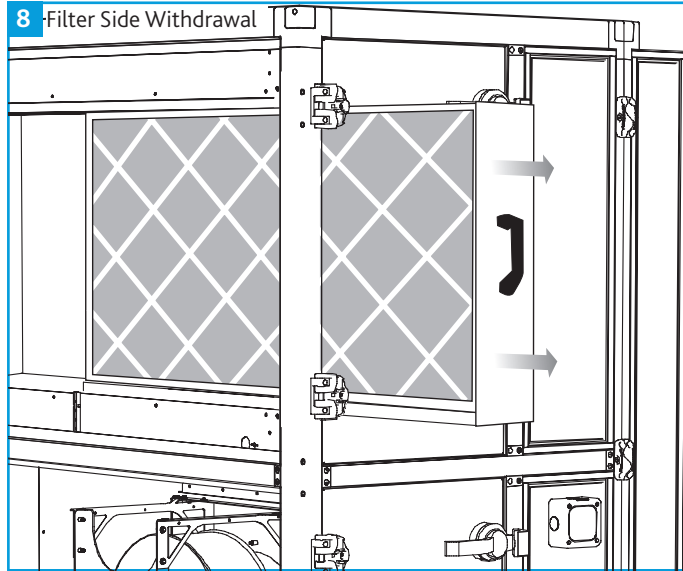

4.10 Control Dampers

Care should be taken to ensure that all spring return actuators have stopped running and completed their stroke. If not, the connection needs to be loosened and the actuator should be left to drive until the motor stops running.

When the unit is powered, dampers should be checked to ensure that they operate freely and close tightly.

Where dampers are protected with a roof terminal, the roof terminal can be removed for access to the main damper. Access to the actuator can be from the side of the roof terminal without the requirement of removing the roof terminal (Figure 9).

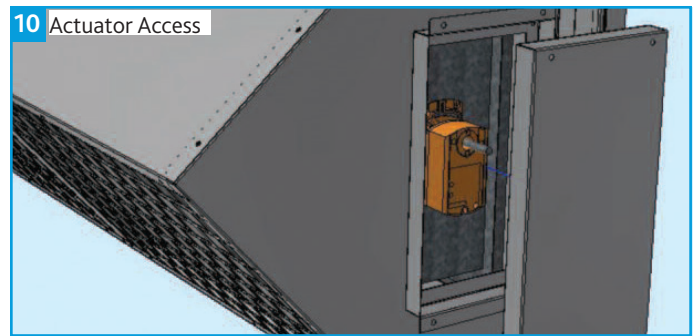
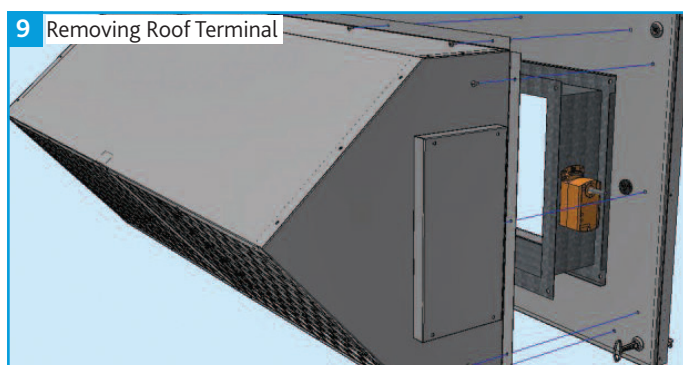

4.11 Damper / Roof Terminal Assembly

The inlet/outlet dampers and roof terminals are pre-assembled (for unit sizes 07 - 17) on a double skinned and insulated panel. The panel is easily fitted to the unit with a series of quarter turns (provided with a locking key) (Figure 11).

For the larger size units (22 - 55) the pre-assembled dampers and terminals are provided with lifting eyes for on-site hoisting into position (Figure 12).

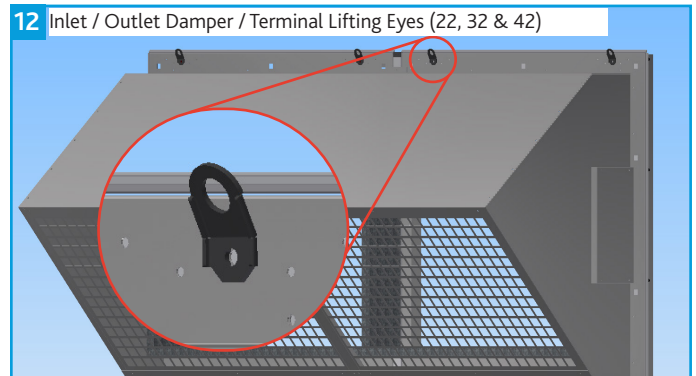
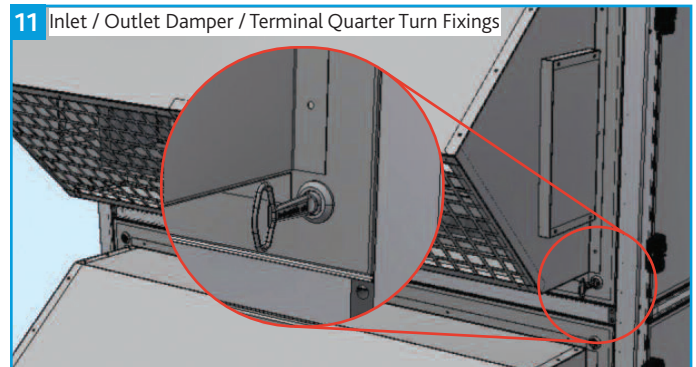

4.12 Supporting Ancillary Items

All ancillary items that are supplied without individual base frames require safe suitable support (supplied by others). This includes but is not limited to single attenuators, terminals and dampers etc.

4.13 Installation Inspection

- Thoroughly inspect the unit after installation is complete.
- The inside of the unit should be checked; any objects which may have been left should be cleared.
- Check fan impellers, scrolls and outlets.
- Remove any transit protection fittings that may be attached to the fan or motor base frame, and that all traps are primed.
- Close all access door seals for damage, and replace any panels that have been removed.

5.0 UNIT ACCESS

13 Unit Access

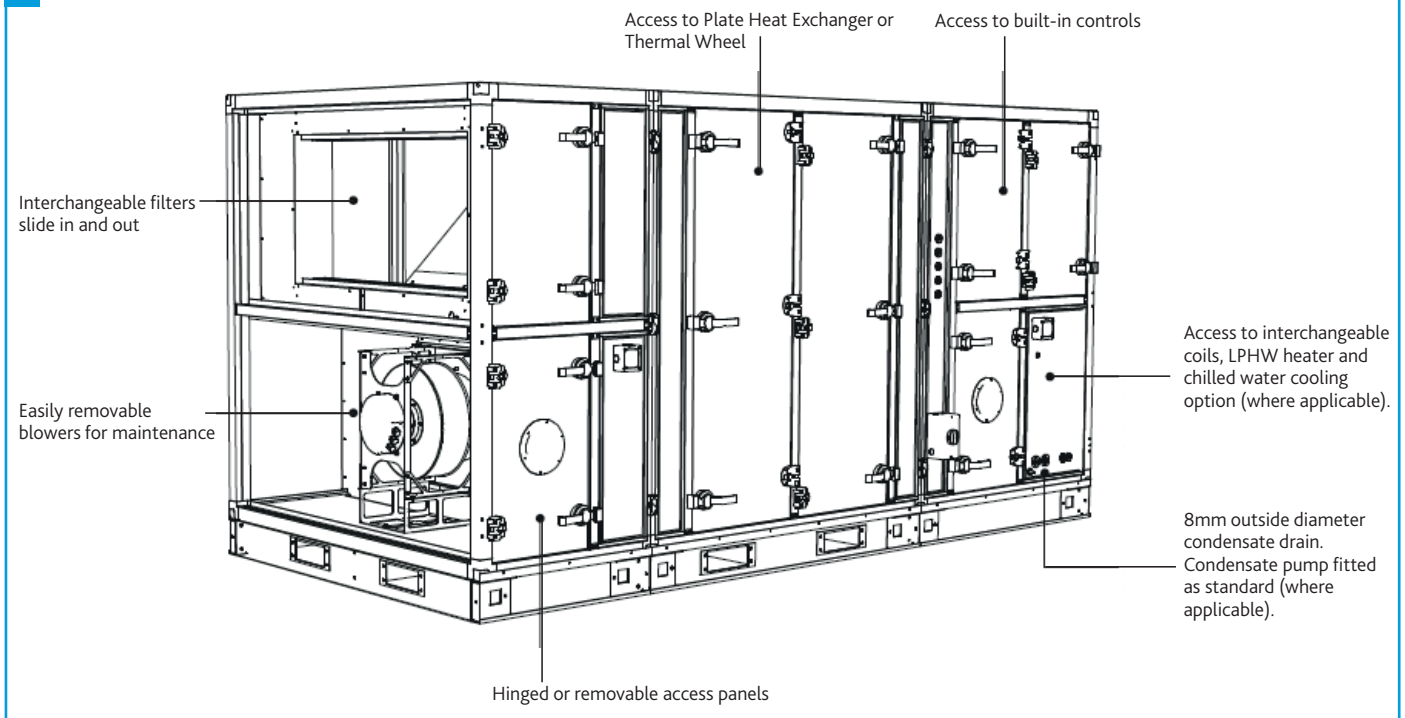

In this product range, several unique concepts have been implemented with a view to simplifying the installation design.

- The unit must be installed with at least 600mm clearance from a wall/barrier. With this absolute minimum clearance, the unit may be connected to the power supply and control connection.
- With this clearance, unit filters may be changed, and the fans coils, heat exchanger and condensate tray may be inspected and cleaned if necessary.
- The LPHW and Electrical heater settings, coil bleed and drain, and all other control adjustments are similarly accessible.
- Side access, where possible, is preferred in all cases in terms of safe working access to the equipment under the CDM regulations.
- Note however, that access in the situation is difficult and additional time should be allocated. For convenience it is preferred that wherever possible, this minimum access provision is not adopted, and it is recommended that a minimum of around 600mm clearance (as stated in ADF 2010) is allowed.
- Where these arrangements are not suitable, the Consultant's and Contractor's project specific requirements will always be accommodated where possible.

5.1 Hinged / Removable Panel Access

All hinged access panels will be lockable and removable via locked hinges which can be opened for panel removal. All keys are identical and will open any handle or hinge.

The hinges do not need to be unlocked in normal operation of opening and closing.

34 Removable Hinged Access Panel (Hinged)



35 Removable Hinged Access Panel (Removed)

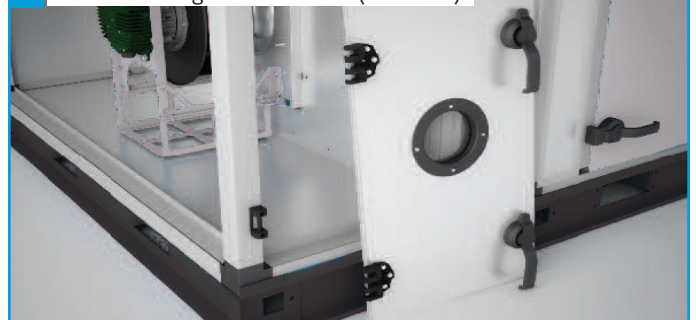

5.2 Access Requirements

5.2.1 Left Hand Thermal Wheel Units

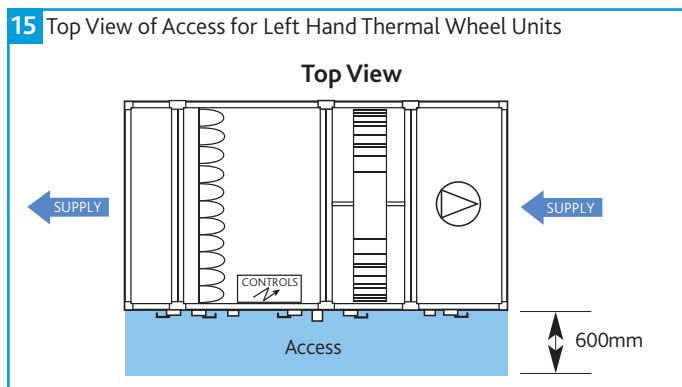
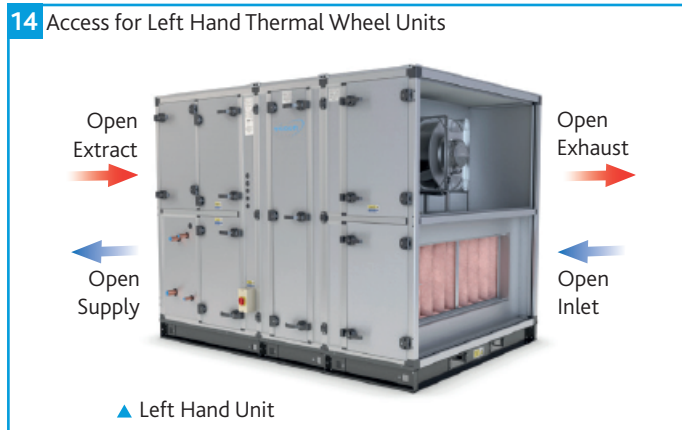

5.2.2 Right Hand Thermal Wheel Units

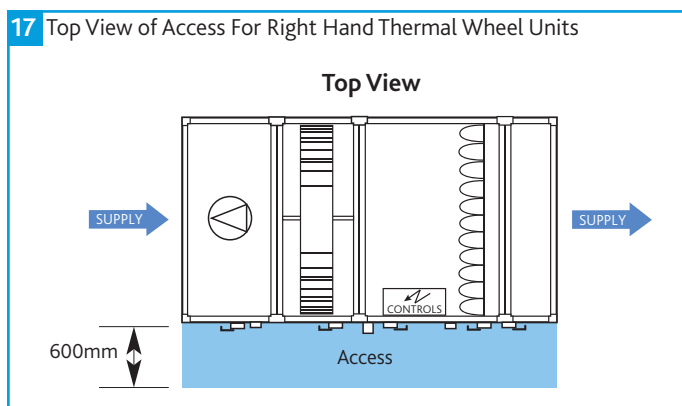
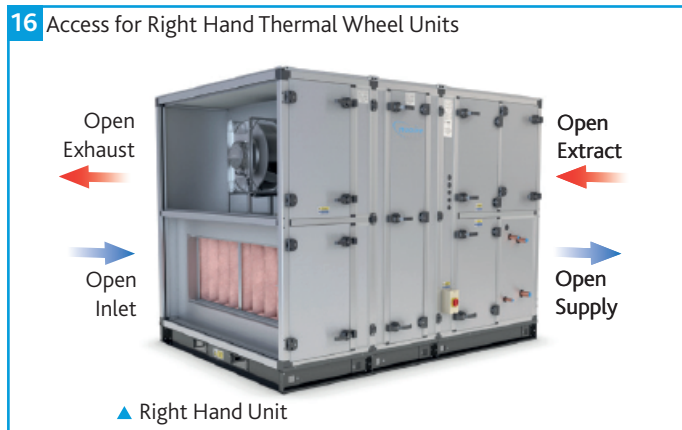

6.0 ELECTRICAL INSTALLATION

The electrical wiring must be carried out by competent persons, in accordance with good industry practice and should conform to all governing and statutory bodies i.e. IEE, CIBSE etc.

6.1 Main Unit Power Supply

The control is powered by a 400Vac 50Hz 3 phase & Neutral supply. This must be isolated local to the unit and fitted with appropriate over-current and fault protection.

6.3 Unit Power Supply Details - FLC

Unit Size	Unit (FLC)	Unit with Electric Heater (Electric Heater Models Only)
N*07T/**AT	8.3 A	8.3 A + 17.5 A †
N*12T/**AT	10.8 A	10.8 A + 35 A †
N*17T/**AT	13.5 A	13.5 A + 52.5 A †
N*22T/**AT	14 A	14 A + 52.5 A †
N*32T/**AT	15 A	15 A + 35 A + 52.5 A ‡
N*42T/**AT	22.5 A	22.5 A + 52.5 A + 52.5 A ‡
N*55T/**AT	33.5 A	N/A

* Denotes any Character.

† These heater models require a separate power supply for the electric heater section, with an appropriate over-current protection device.

‡ These heater models require two separate power supplies for the two (2) electric heater sections, each with an appropriate over-current protection device.

6.4 Wiring

All inter-connections between circuit boards, blowers and sensors are made at the factory. This diagram only shows the essential field wiring points for clarity.

Remove link wire if switched live signal, an enabler or BMS signal is connected.

If inlet and outlet dampers are fitted, remove the damper link wires. This will allow a 1 minute delay before starting the fans.

6.4.1 Switch Live

Switch Live (SL) terminal - A signal of 100-230V a.c. will activate the switch live signal.

Switch Live 2 (SL2) terminal - A signal of 100-230V a.c. will activate the switch live 2 (Fan Boost) signal.

A signal from an isolating transformer will produce an unpredictable result and is not recommended.

Extra low voltage versions of the switched live signals are also available. Link two contacts to activate the signal.

6.4.2 Volt Free Contacts

The volt free contacts are not fused. If these are used to power any external equipment, the installer must provide adequate fusing or other protections.

Fault - The relay is unpowered when a fault is present.

Heat Demand - The relay is powered when heating is selected.

Cool Demand - The relay is powered when cooling is selected.

6.2 Electric Heater Power Supply

For models with electric heating, the heating circuit is powered by 1 or 2 separate, higher current, 400Vac 50Hz 3 phase & Neutral supplies. This must be isolated to the unit and fitted with appropriate over-current protection. The main supply is still required. Electric heater elements are protected by a fail-safe over-temperature switch which will disconnect the heater supply if a temperature of 80°C is reached. Once the elements cool, the switch will reset but a power cycle is required to reset the heater supply contactor.

6.4.3 Fan Start Delay

A fan start delay can be imposed to allow the damper time to open. This is adjustable via display screens or commissioning tools.

If an I/O damper is fitted, it must be wired to the fan run relay, and the relay supplied with the relevant supply voltage.

If required the damper end point relay can be connected in series with alarm circuit 2 to monitor for damper faults. The multi-state value 'IO Damper Fitted' must be set to yes. This will allow the system to ignore alarm circuit 2 if the fans are not running and dampers are closed.

See I/O Damper connection diagram for details.

6.4.4 Network Settings

Default MS/TP Address: 4
BACnet Instance Number: Randomised & Unique for each controller (0 to 4,194,304)

6.5 Connection Chart

Description	Controller Terminal No	Din Rail Terminal No	DI	AI	Relay Output	AO (0-10v)
Fresh Air Sensor	IN1			1		
Supply Air Sensor	IN2			1		
Return/Room Air Sensor	IN3	30,31		1		
Input 4 (Pressure Sensor)	IN4			1		
Input 5	IN5	36,37		1		
Alarm Circuit 1 (Fan, Heater)	IN6	32,33	1			
Alarm Circuit 2 (Pump, Filter, Thermal Wheel, IO Damper)	IN7	34,35	1			
Enable Input Signal	IN8	38,39	1			
Configurable Input Signal (SL2)	IN9	40,41	1			
Extract Fan 0-10V	OUT1					1
Supply Fan 0-10V	OUT2					1
Heat Demand 0-10V	OUT3					1
Cool/Reverse-Cycle Demand 0-10V	OUT4					1
HX Bypass Relay	OUT5				1	
Fault Relay (De-energise on fault)	OUT6				1	
Fan Run Relay	OUT7				1	
Cool/Reverse-Cycle Demand Relay	OUT8				1	
Recirculation Damper Relay	OUT9				1	
230V Enable Input		10				
230V Configurable Input		11				

6.6 Isolator Wiring Points

Main wiring points for the customer is to the isolators situated on the sides of the units as shown below.

Cable glands are for additional ancillary cabling and are located on the sides of the units.

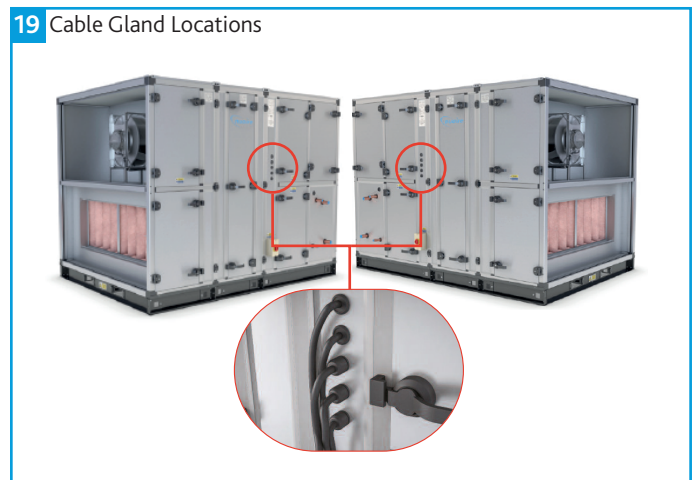
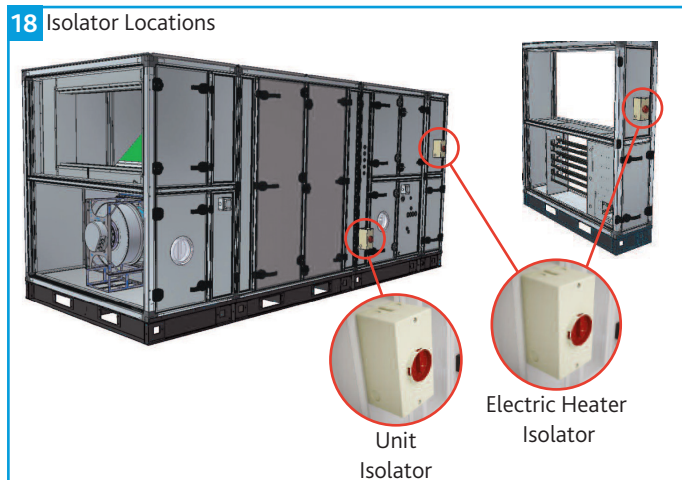

6.7 Terminal Wire Connections

6.7.1 Push In Termination

Stripped solid conductors, fine-stranded conductors with ferrules, or ultrasonically “bonded” conductors are simply pushed in until they hit the backstop. No tools are required.

6.7.2 Termination Of Fine Stranded Conductors

Open the clamp by inserting an operating tool (as shown below) until it clicks into position. Then insert the conductor and remove the operating tool to complete the connection.

20 Wiring a Conductor to a Terminal

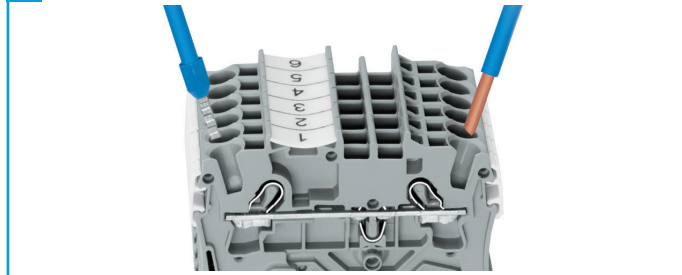

6.7.3 Conductor Removal

Insert an operating tool in to the operating slot to remove the conductor, just like the original CAGE CLAMP® terminals blocks.

21 Removing a Conductor from a Terminal

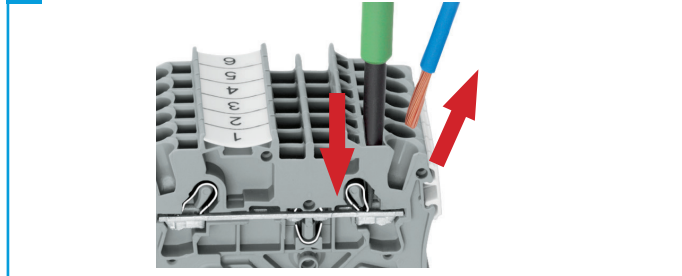

6.7.4 Jumpers

Terminal blocks can be commoned together to increase the number of terminals at the same potential using push-in jumpers. In these cases the terminals are treated as one conductor.

22 Removing a Jumper Pin

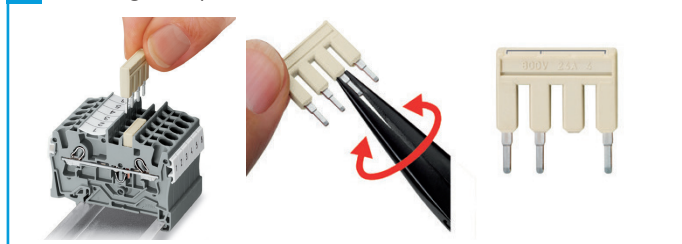

6.7.5 Jumper Removal

Insert the operating tool blade between the jumper and the partition wall of the dual jumper slots, then lift up the jumper.

23 Removing a Jumper

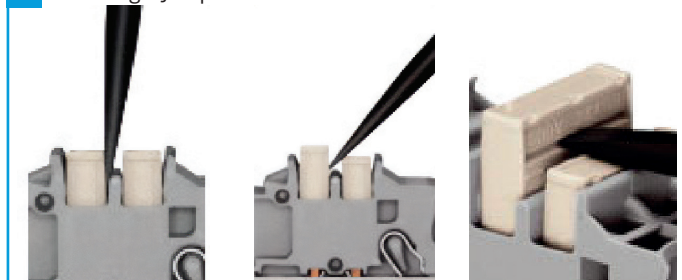

6.7.6 Double Deck Termination Block

Each deck has a different potential (2-conductor), which creates a space saving on the rail. Decks can be commoned to adjacent terminal blocks and / or the top to the bottom deck.

24 Double Deck Conducting Paths

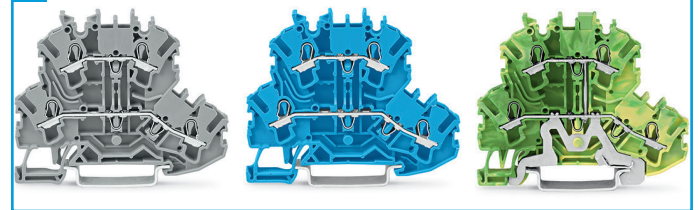

6.7.7 Earth Terminals

The earth terminal block (green/yellow) has a direct electrical connection to the DIN rail, with the earthing foot (earth connection only).

25 Earth Terminal Block



6.7.8 Fuse Terminals

26 Fuse Terminal Block

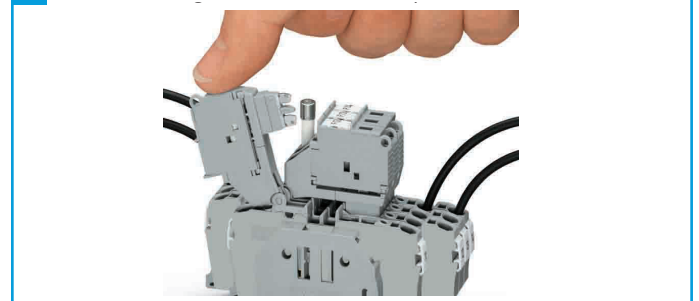

6.8 Wiring Diagrams

A series of basic connection wiring diagrams have been provided to assist on-site wiring. In order to reference the relevant diagrams please use the code breakdown opposite to determine:

- Unit size
- If an electric heater is present
- If Reverse Cycle DX heating or cooling is present.

The below tables can then be used to reference the required connection and wiring diagrams.

Example:

Unit on site has code **N22T/EC/CO-L**. This indicates a size 22 unit with electric heating (Section 6.9.2)

6.8.1 Code Description:

N	07	T	/	L	N	/	CO	-	L	WP	4
	1		/	2	3	/		-			

- Unit Size: **07, 12, 17, 22, 32 42 or 55**
- Heating Type: **E** = Electric (07 - 42 Only)
L = Low Pressure Hot Water (LPHW)
N = No Heating
- Cooling Type: **C** = Chilled Water (CW)
N = No Cooling
X = Reverse Cycle DX (condenser unit and controls by others)

6.8.2 Wiring Diagram Reference Table

Unit Size	Unit Contains NO or LPHW Heater	Unit Contains Electric Heater
07	Section 6.9.1	Section 6.9.2
12	Section 6.9.1	Section 6.9.2
17	Section 6.9.1	Section 6.9.2
22	Section 6.9.1	Section 6.9.2
32	Section 6.9.1	Section 6.9.3
42	Section 6.9.1	Section 6.9.3
55	Section 6.9.1	N/A

6.9 Wiring Diagrams

6.9.1 Unit Sizes 07 - 55 with No or LPHW Heating & No or CHW Cooling

27 Unit Sizes 07 - 55 with No or LPHW Heating Wiring & No or CHW Cooling Diagram

Key:

- Factory Connection (Blue line with circle)
- Customer Connection (Mandatory) (Pink line with circle)
- Customer Connection (Optional) (Dotted line with circle)

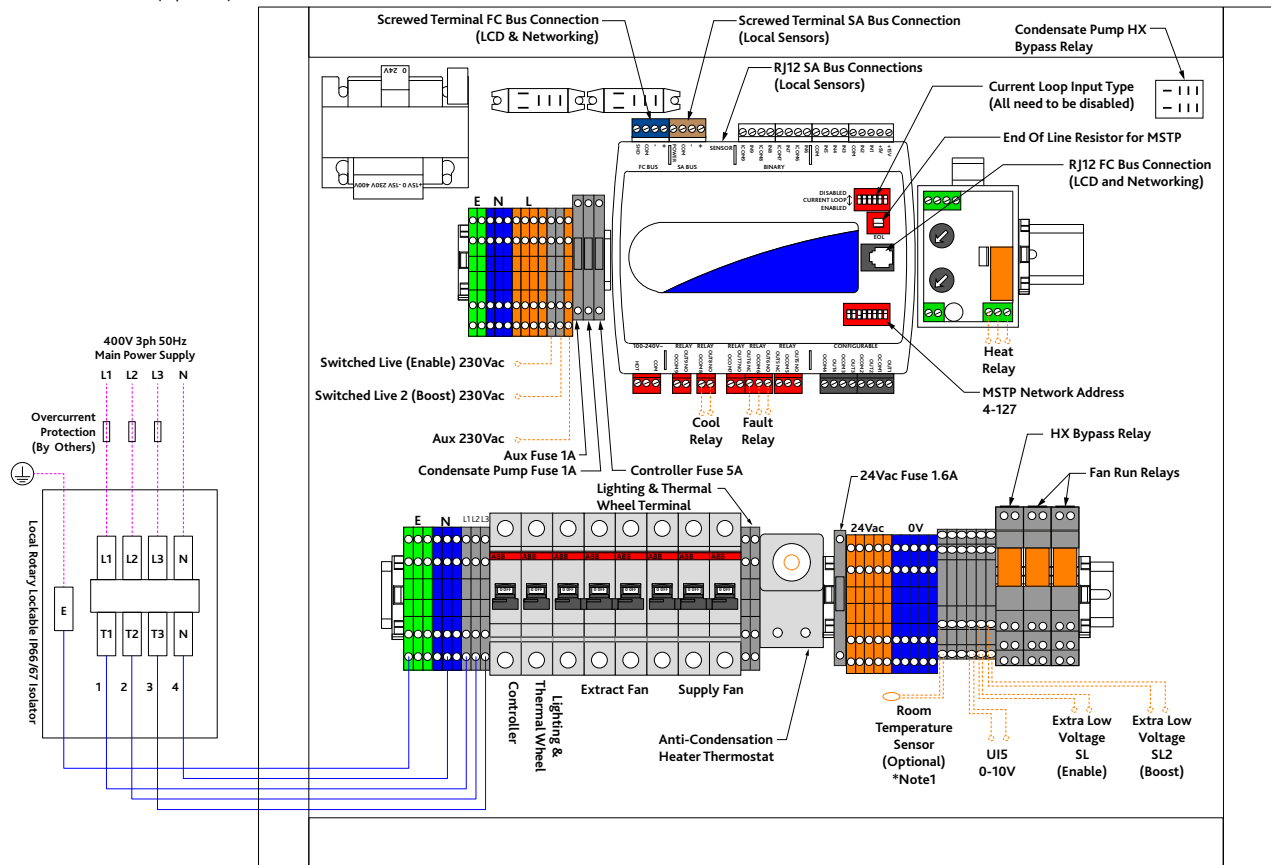

Internal Connection are not shown for clarity.

* Note 1
Connect space temperature sensor in place of extract temperature sensor for space temperature control.

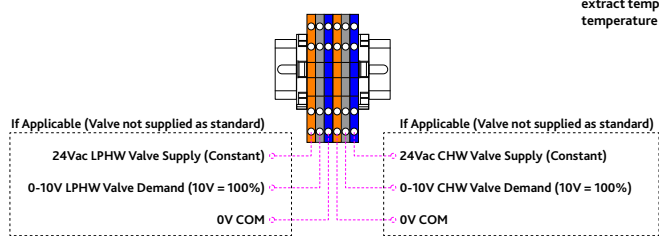

6.9.2 Unit Sizes 07 - 22 with Electric Heating & No or CHW Cooling

28 Unit Sizes 07 - 22 with Electric Heating & No or CHW Cooling Wiring Diagram

Key:

- Factory Connection —○—
- Customer Connection (Mandatory) —○—
- Customer Connection (Optional) —○—

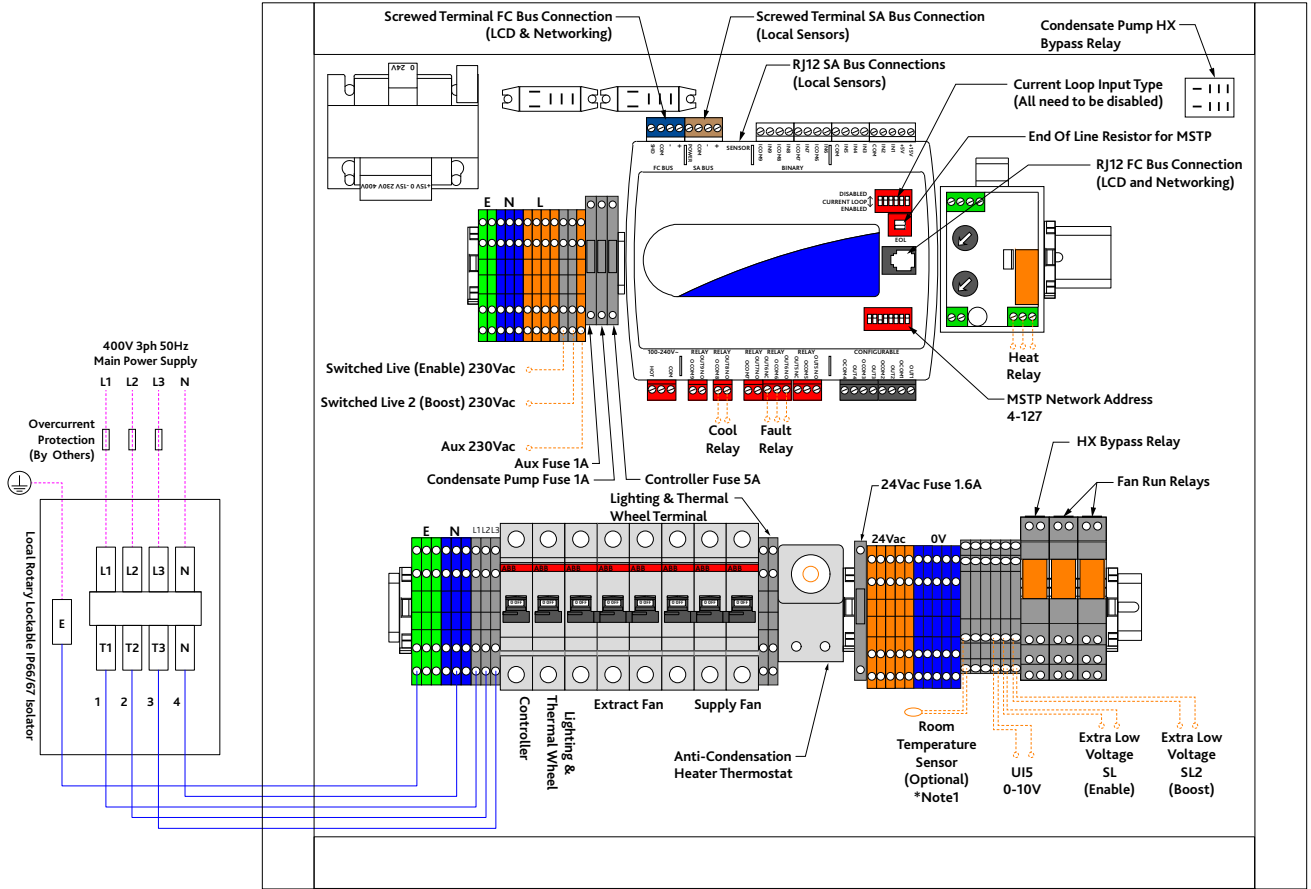

Internal Connection are not shown for clarity.

* Note 1
Connect space temperature sensor in place of extract temperature sensor for space temperature control.

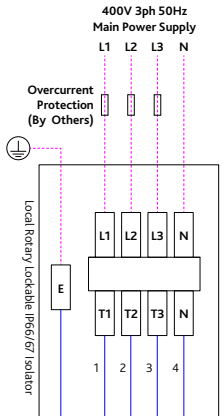

All internal connections between the heater section and the main section are made via interconnection looms. No external connections need to be made.
The electric heater air off temperature is set by an adjustment knob inside the electric heater section.

**Electric Heater Section
1 Supply Required**

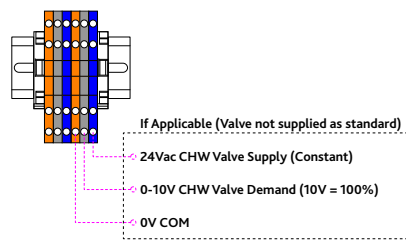

6.9.3 Unit Sizes 32 - 42 with Electric Heating & No or CHW Cooling

29 Unit Sizes 32 - 42 with Electric Heating & No or CHW Cooling Wiring Diagram

Key:

- Factory Connection —○—
- Customer Connection (Mandatory) —○—
- Customer Connection (Optional) —○—

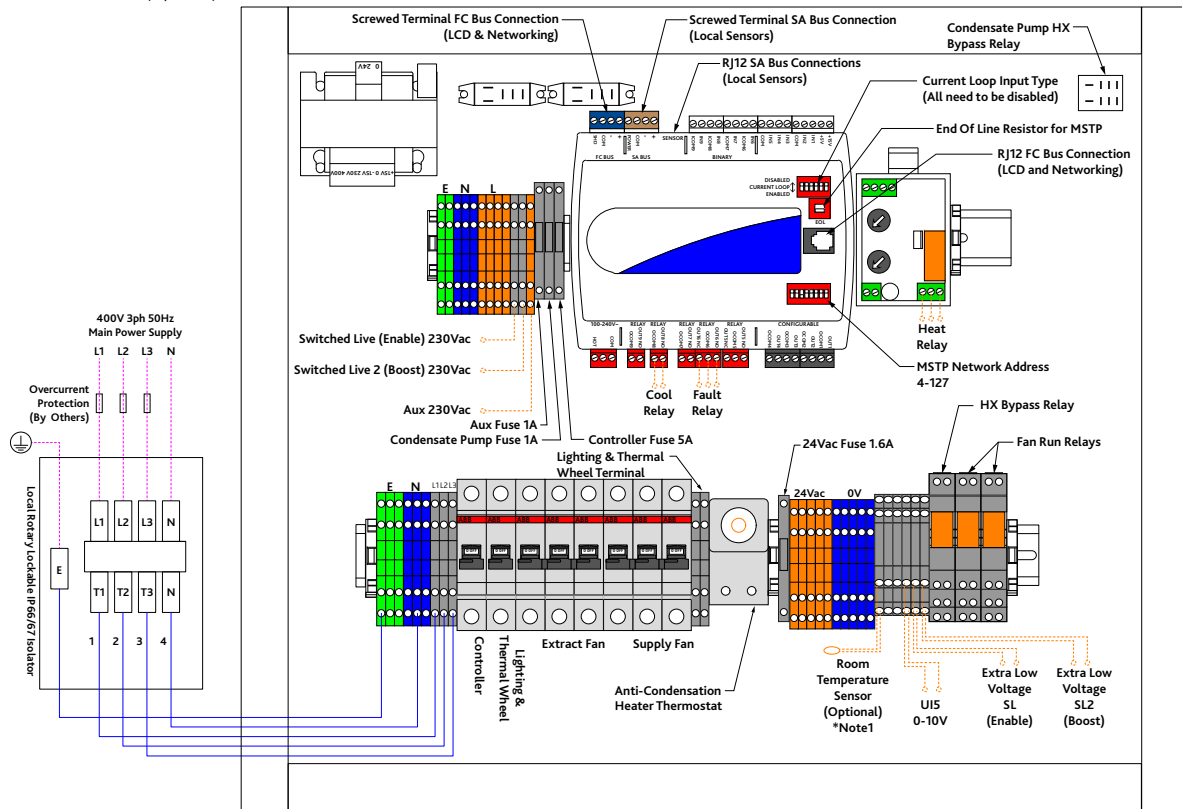

Internal Connections are not shown for clarity.

* Note 1
Connect space temperature sensor in place of extract temperature sensor for space temperature control.

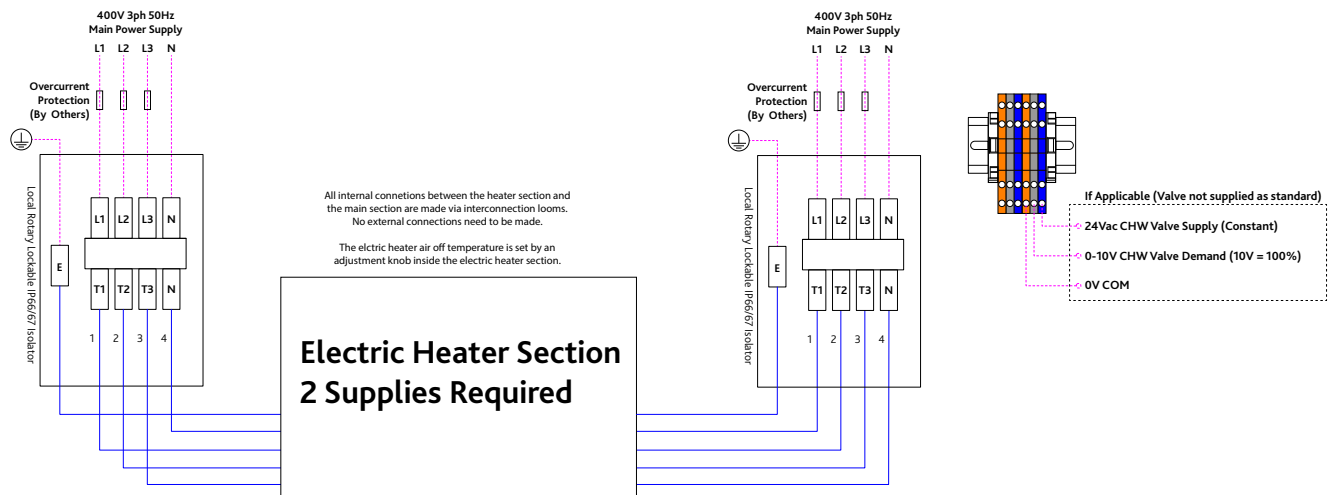

**Electric Heater Section
2 Supplies Required**

All internal connections between the heater section and the main section are made via interconnection looms. No external connections need to be made.
The electric heater air off temperature is set by an adjustment knob inside the electric heater section.

If Applicable (Valve not supplied as standard)
 • 24Vac CHW Valve Supply (Constant)
 • 0-10V CHW Valve Demand (10V = 100%)
 • 0V COM

7.0 FROST COIL INSTALLATION (OPTIONAL ANCILLARY)

7.1 LPHW Frost Coil

LPHW frost coils are fitted with a frost stat on the air in side and an on/off 230v valve actuator (Unit size 32 & 42 are NOT provided with valve and actuator). If the frosts stat switches to a frost condition, the valve actuator will open. The valve will open whether the fans are running or not. This is for pipe freeze protection. The LPHW section requires its own supply in order to power the valve actuator.

7.2 Wiring - LPHW Frost Coil

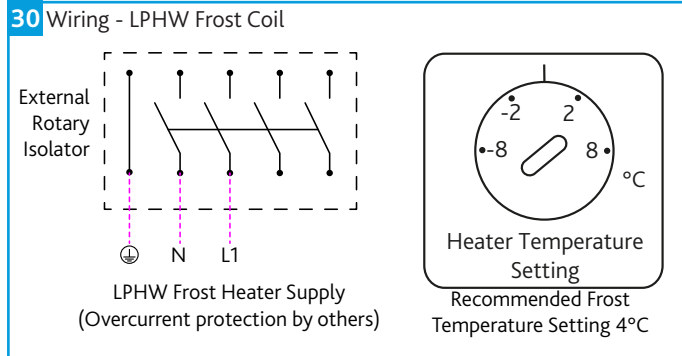

7.3 Electric Heater Frost Coil

Electric heater frost coils are fitted with its own internal control panel. The control is powered by a 400Vac 50Hz 3 phase & Neutral supply. This must be isolated local to the unit and fitted with appropriate overcurrent and fault protection. It connects to the main unit via “plug and play” interconnecting looms. (See interconnection section for details). No external connections are required. Electric heater elements are protected by a fail-safe over-temperature switch which will disconnect the heater supply if a temperature of 80°C is reached. Once the elements cool, the switch will reset but a power cycle is required to reset the heater supply contactor.

The frost coil is fitted with a burst fired controller with integral set point, air off thermistor, air in frost stat, thermal cut-out and contactor. The burst fired controller is only enabled if the frost stat reads a frost condition, the over-temperature cut-out is healthy AND a 24vac fan run signal is received from the main control panel. Once enabled the burst fired controller will increase heating output to achieve the set point set by the physical dial on the unit.

7.4 Wiring - Electric Heater Frost Coil Unit Sizes 07 - 22

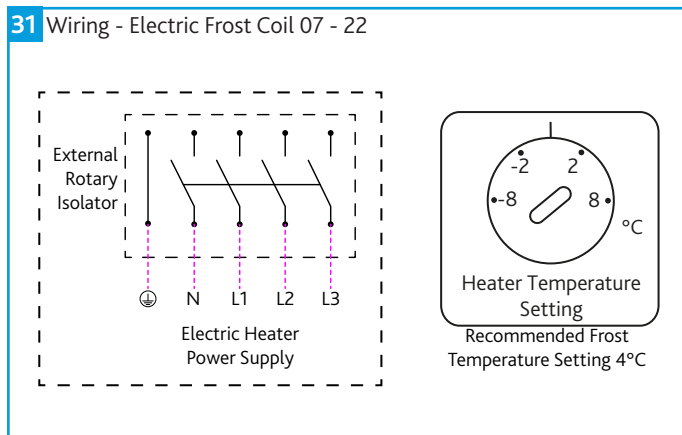

7.5 Wiring - Electric Heater Frost Coil Unit Sizes 32 - 42

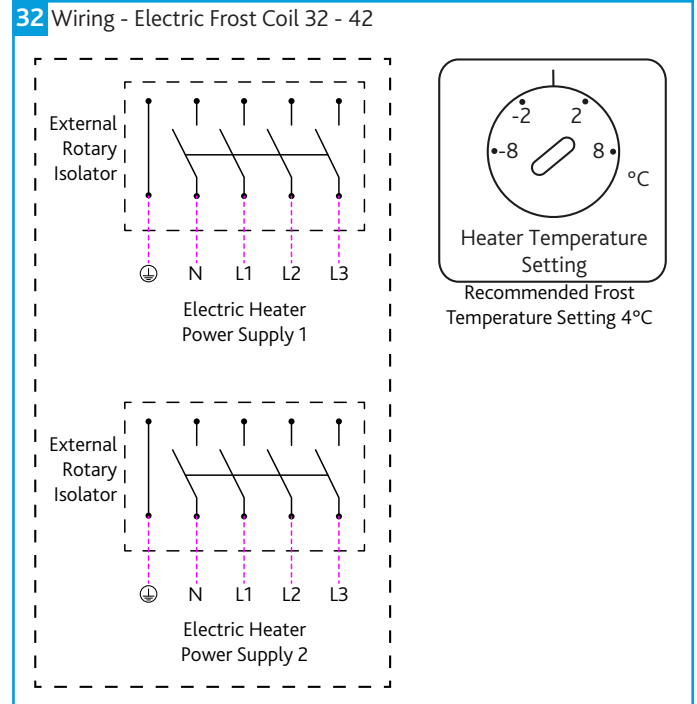

7.6 Electrical Supply FLC's

‡ Double electric heater models require separate supplies for two heater sections, each with an appropriate overcurrent current protection device.

Frost Heater Size & Type	Frost Heater FLC (Ancillary)
N07AT/FE-* (Electric)	17.5 A
N07AT/FL-* (LPHW)	0.1 A
N12AT/FE-* (Electric)	35 A
N12AT/FL-* (LPHW)	0.1 A
N17AT/FE-* (Electric)	52.5 A
N17AT/FL-* (LPHW)	0.1 A
N22AT/FE-* (Electric)	52.5 A
N22AT/FL-* (LPHW)	0.1 A
N32AT/FE-* (Electric)	52.5 A + 35 A ‡
N32AT/FL-* (LPHW)	0.1 A
N42AT/FE-* (Electric)	52.5 A + 52.5 A ‡
N42AT/FL-* (LPHW)	0.1 A
N55AT/FL-* (LPHW)	0.1 A

8.0 CONTROLS

See EcoSmart Connect control operation manual (document number 672040) for detailed controls information. A quick controls guide is also available (document number 671868).

9.0 COMMISSIONING

Before commissioning the unit, ensure that all equipment has been assembled in accordance with the installation procedure all instances where the unit is in operation the access doors should remain closed; at no time, during maintenance or otherwise, should anyone be inside a unit whilst it is in operation.

9.1 Fan & Motor

Care should be taken to ensure that the fan and motor run freely and that the fan is rotating in the correct direction.

The electrical current being drawn by motors should not exceed the manufacturers recommendations (specified on the motor plate). If the current exceeds this, check the fan volume flow rate and the static resistance.

9.2 Commissioning Checklist

- All equipment received is according to specification/order.
- Any damage to unit identified.
- Fan base shipping restraints / Fixing Brace removed (if applicable).
- The correct installation procedure has been carried out in accordance to Nuair's recommendations.
- Any fan and thermal wheel motor pulleys are properly aligned.
- Anti-vibration mounts are adjusted accordingly.
- Check / adjust fan and thermal wheel belt tension.
- Rotate fan impellers and motors to ensure they run freely.
- Check any additional bearings and couplings (where fitted manually).
- Condensate drain traps are checked. Check all filters are correctly fitted.
- Ensure ductwork is complete.
- Check electrical supply voltage and tightness of all electrical connections.
- Ensure control damper operation.
- Ensure access panels and doors are fitted properly and secure.
- Check fan motor current draw.

10.0 MAINTENANCE

It is important that maintenance checks are recorded and that the schedule is always adhered to, in all cases, the previous report should be referred to.

10.1 Fans

Please refer to general arrangement drawings for details of the type of fan and drive that is fitted. Maintenance guidelines for all fans are beyond this manual, please contact Nuair for specific documents.

- Before any work is carried out, please ensure that:
 - The power supply to the motor is switched off.
 - The fan impeller is at rest.

Measures are taken to ensure that the accidental, uncontrolled running of the fan is prevented during maintenance work.

In general, fans should be inspected twice a year, and care should be taken to ensure that any unusual vibration or sound is investigated as an urgent matter.

Access to the fan section is via hinged or lift-off panels. Cable entry must be made through the apertures provided. Screwed glands with cable restraint devices should be used.

10.2 General Fan Maintenance

Access to the fan is normally gained by opening the hinged access doors.

Care should be taken to remove any build up of dust (a light vacuum or light brushing will normally take care of this) Do not use a steam or any other high pressure cleaners.

Inspect the connection between the fan and unit for any damage or wear and tear.

10.3 Bearings

The bearings that are fitted will be (unless otherwise specified) "sealed for life", therefore consequence maintenance is not required.

Fan bearings are lifelong; up to 40,000 hours of operation. In cases of heavy duty operation, maintenance intervals are to be established by the operator.

10.4 Filters

When removing the filter access panels, pay attention to the airflow direction marked on the panel, this must be replaced to the exact position prior to being removed. Disposable filters should be checked, and changed when they become fully laden with dust. Washable filters should be removed and washed in a mild detergent, flushed with clean water and allowed to dry before refitting.

10.5 Coils

Coils should be connected to ensure that full counter flow exists i.e. the entering airflow meets the return connection.

All coils should be connected with the flow at the bottom and the return at the top unless otherwise advised. Drain and bleed valves are located on the coil, others may be required in the system pipe-work depending on the installation.

Frost protection must be incorporated on shut down and fresh air conditions to avoid coil freezing. Ideally, where the system is at risk of frost damage, the addition of a proprietary antifreeze solution to the water is recommended.

Pipe-work connections should be made to the unit using appropriate techniques, and must be independently supported. The connections should be pressure tested.

All coils sit in a common drip tray connected to the pre-fitted condensate pump.

The coil panel has been pre-drilled and fitted with appropriate grommets for pipe connections. Do not drill or cut the unit casing for this purpose.

Coils should have their finned surface examined for accumulation of dirt, lint and biological contaminants or similar. If necessary, wash down affected areas with a mild detergent solution and a soft brush. Care should be taken not to damage the finned surface, and any cleaning fluids should be rinsed away with water.

A compressed air line may be used to blow out any solids between fins. Do not probe the coil fin block with metal objects as damage may cause leaks. Drain lines should be checked to ensure that they are unobstructed and free draining. Drain pans should be flushed out periodically to remove contamination.

The unit application may require particular attention to this item – Check with Building Management personnel for details.

10.6 Thermal Wheel

After the 2-3 weeks of operation, and at least once per year, ensure the following maintenance is performed.

- Check that rotor is vertical and centred in casing. Adjust vertical and horizontal position if needed.
- Check the thermal wheel spins freely.
- Adjust sealing to ensure contact with the rotor and side plates. Replace brush sealing if it is worn.
- Check that motor bracket is in 20-45° angle from horizontal line.
- Adjust length of drive belt if needed.
- Check condition of belt and belt lock (joint).

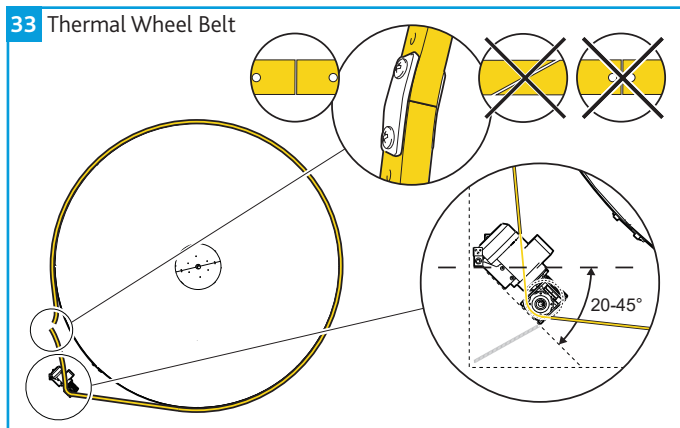

Experience shows that clogging of heat exchangers is not expected in normal cooling and air-conditioning systems. However, if deposits accumulate on the exchanger when used for special applications, it can be cleaned as follows:

Remove dust and fibres with a soft brush or vacuum cleaner. Use caution when blowing dirt out with compressed air to avoid damage to the wheel. Keep at a distance!

Oils, solvents etc. can be removed with hot water (max. 70 °C) or grease-removing solvents or immersion.

10.7 Legionella Check

Legionella risk management should be undertaken by a competent person appointed by the duty holder in accordance with the latest edition of the HSE approved code of practice L8 Legionnaires' disease, the control of legionella bacteria in water systems. Particular attention should be given to:

- Cooling coil.
- Thermal Wheel.
- Drain trays.
- Water reservoirs.

10.8 Electric Heaters

An air handling unit would normally require no heater maintenance. However a periodic check is advised to ensure that the fasteners and electrical connections are operating correctly.

The electric heater unit is fitted with fail-safe thermal switches (self-resetting) which will isolate the electric heater supply if a temperature of 80°C is detected. This action is performed independently of any controls fitted. Nuair fitted controls will also stop heating if a fan or heater failure is detected.

10.9 Bulkhead Lights

Ensure that lights are switched off and isolated before checking or changing the lamp.

10.10 General

Inspect all internal and external surfaces to check for corrosion or peeling of painted surfaces.

Thoroughly clean affected areas with a wire brush, apply a coat of zinc rich primer or similar, and re-touch with suitable finishing paint. Ensure tightness of all nuts, bolts, and fixings.

Check all components for general condition.

10.11 Specialist Equipment

Contact Nuair for maintenance of specialised equipment that would have been specified during design stage. A breakdown of the component parts can be found on the design specification documents, additional maintenance literature is available, please contact Nuair.

This applies to any components not specifically mentioned in this document.

10.12 Maintenance Schedule

10.12.1 Routine Maintenance

- Clean all areas of unit and treat any areas of corrosion.
- Check all access doors for leakage and if necessary locks should be adjusted and any replacement gasket materials should be replaced as required.
- Any drain trays should be cleaned and repaired if necessary.

10.12.2 Every 3 Months

- Check filters and change/clean if required, failure to do so may impair the performance and energy efficiency of this unit.
- Ensure condensate drains are cleaned clear and that water can flow freely from unit.
- Check fin coil banks and heat exchangers. If necessary clean with a soft brush or vacuum. Check for signs of contamination.

10.12.3 Annually

- Thoroughly inspect the unit and its components for corrosion, acting immediately to treat/restore any damaged areas.
- All electrical terminals within the unit should be tightened.
- Check all earth connections.
- Check control dampers blades.
- Check operation of damper actuators and linkages and adjust as necessary.
- Coil faces should be inspected and any dust removed.
- Check any thermal wheel belt, motor, bearings, seals and if necessary clean with a soft brush or vacuum cleaner.

11.0 WARRANTY

The 5 year warranty starts from the day of delivery and includes parts and labour for the first year. The remaining period covers replacement parts only.

This warranty is void if the equipment is modified without authorisation, is incorrectly applied, misused, disassembled, or not installed, commissioned and maintained in accordance with the details contained in this manual and general good practice.

The product warranty applies to the UK mainland and in accordance with Clause 14 of our Conditions of Sale. Customers purchasing from outside of the UK should contact Nuaire International Sales office for further details.

Failure to maintain the unit as recommended will invalidate the warranty.

12.0 END-OF-LIFE AND RECYCLING

Where possible Nuaire use components which can be largely recycled when the product reaches its end-of-life:

- Fans, motors, controls, actuators, cabling and other electrical components can be segregated into WEEE recycling streams.
- Sheet metal parts, aluminium extrusion, heating/cooling coils and other metallic items can be segregated and fully recycled.
- EPP, plastic ducting, nylon corner pieces, plastic heat exchangers, packaging material and other plastic components can be segregated into mixed plastic and widely recycled.
- Cardboard packaging, wood, used filters and other paper components can be largely recycled or fully processed in energy from waste centres.
- Remaining Items can be further segregated and processed in accordance with the zero waste hierarchy. Please call After Sales Support for further information on items not listed above.

Ensure that Nuaire product is made safe from any electrical / water / refrigerant supplies before dismantling commences. This work should only be undertaken by a qualified person in accordance with local authority regulations and guidelines, taking into account all site based risks.

13.0 AFTER SALES AND REPLACEMENT PARTS

For technical assistance or further product information, including spare parts and replacement components, please contact the After Sales Department.

If ordering spares please quote the serial number of the unit together with the part number, if the part number is not known please give a full description of the part required. The serial number will be found on the identification plate attached to the unit casing.

Telephone 02920 858 400
aftersales@nuaire.co.uk

Technical or commercial considerations may, from time to time, make it necessary to alter the design, performance and dimensions of equipment and the right is reserved to make such changes without prior notice.

DECLARATION OF INCORPORATION AND INFORMATION FOR SAFE INSTALLATION, OPERATION AND MAINTENANCE

We declare that the machinery named below is intended to be assembled with other components to constitute a system of machinery. All parts except for moving parts requiring the correct installation of safety guards comply with the essential requirements of the Machinery Directive. The machinery shall not be put into service until the system has been declared to be in conformity with the provisions of the EC Machinery Directive.

Designation of machinery: Neptune AHU Models



Machinery Types: Supply and Extract Fans with Heat Recovery

Relevant EC Council Directives: 2006/42/EC

Applied Harmonised Standards: BS EN ISO 12100:2010, EN60204-1, BS EN ISO 9001, BS EN ISO 13857

Applied National Standards: BS848 Parts 1, 2.2 and 5

Signature of manufacture representatives:

Name:		Position:	Date:
1)A. Thomas		Engineering Director	18. 06. 16
2)C. Sargent		Manufacturing Director	18. 06. 16

Note: All standards used were current and valid at the date of signature.

INFORMATION FOR SAFE INSTALLATION, OPERATION AND MAINTENANCE OF NUAIRE VENTILATION EQUIPMENT

To comply with EC Council Directives 2006/42/EC Machinery Directive and 2014/30/EU (EMC). To be read in conjunction with the relevant product documentation (see 2.1)

- | | |
|---|--|
| <p>1.0 GENERAL</p> <p>1.1 The equipment referred to in this Declaration of Incorporation is supplied by Nuairé to be assembled into a ventilation system which may or may not include additional components. The entire system must be considered for safety purposes and it is the responsibility of the installer to ensure that all of the equipment is installed in compliance with the manufacturers recommendations and with due regard to current legislation and codes of practice.</p> <p>2.0 INFORMATION SUPPLIED WITH THE EQUIPMENT</p> <p>2.1 Each item of equipment is supplied with a set of documentation which provides the information required for the safe installation and maintenance of the equipment. This may be in the form of a Data sheet and/or Installation and Maintenance instruction.</p> <p>2.2 Each unit has a rating plate attached to its outer casing. The rating plate provides essential data relating to the equipment such as serial number, unit code and electrical data. Any further data that may be required will be found in the documentation. If any item is unclear or more information is required, contact Nuairé.</p> <p>2.3 Where warning labels or notices are attached to the unit the instructions given must be adhered to.</p> <p>3.0 TRANSPORTATION, HANDLING AND STORAGE</p> <p>3.1 Care must be taken at all times to prevent damage to the equipment. Note that shock to the unit may result in the balance of the impeller being affected.</p> <p>3.2 When handling the equipment, care should be taken with corners and edges and that the weight distribution within the unit is considered. Lifting gear such as slings or ropes must be arranged so as not to bear on the casing.</p> <p>3.3 Equipment stored on site prior to installation should be protected from the weather and steps taken to prevent ingress of contaminants.</p> <p>4.0 OPERATIONAL LIMITS</p> <p>4.1 It is important that the specified operational limits for the equipment are adhered to e.g. operational air temperature, air borne contaminants and unit orientation.</p> <p>4.2 Where installation accessories are supplied with the specified equipment e.g. wall mounting brackets. They are to be used to support the equipment only. Other system components must have separate provision for support.</p> <p>4.3 Flanges and connection spigots are provided for the purpose of joining to duct work systems. They must not be used to support the ductwork.</p> <p>4.4 Local Environment - Humidity. Ambient humidity (the humidity at the unit's installed location) shall be within the range: 10 to 95% (for controls, non-condensing). Air humidity (the humidity of the air passing through the unit) shall be within the range: 10 to 95% (for controls, non-condensing).</p> | <p>5.0 INSTALLATION REQUIREMENTS</p> <p>In addition to the particular requirements given for the individual product, the following general requirements should be noted.</p> <p>5.1 Where access to any part of equipment which moves, or can become electrically live are not prevented by the equipment panels or by fixed installation detail (e.g. ducting), then guarding to the appropriate standard must be fitted.</p> <p>5.2 The electrical installation of the equipment must comply with the requirements of the relevant local electrical safety regulations.</p> <p>5.3 For EMC all control and sensor cables should not be placed within 50mm or on the same metal cable tray as 230V switched live, lighting or power cables and any cables not intended for use with this product.</p> <p>6.0 COMMISSIONING REQUIREMENTS</p> <p>6.1 General pre-commissioning checks relevant to safe operation consist of the following:
Ensure that no foreign bodies are present within the fan or casing.
Check electrical safety e.g. Insulation and earthing.
Check guarding of system.
Check operation of Isolators/Controls.
Check fastenings for security.</p> <p>6.2 Other commissioning requirements are given in the relevant product documentation.</p> <p>7.0 OPERATIONAL REQUIREMENTS</p> <p>7.1 Equipment access panels must be in place at all times during operation of the unit, and must be secured with the original fastenings.</p> <p>7.2 If failure of the equipment occurs or is suspected then it should be taken out of service until a competent person can effect repair or examination. (Note that certain ranges of equipment are designed to detect and compensate for fan failure).</p> <p>8.0 MAINTENANCE REQUIREMENTS</p> <p>8.1 Specific maintenance requirements are given in the relevant product documentation.</p> <p>8.2 It is important that the correct tools are used for the various tasks required.</p> <p>8.3 If the access panels are to be removed for any reason the electrical supply to the unit must be isolated.</p> <p>8.4 A minimum period of two minutes should be allowed after electrical disconnection before access panels are removed. This will allow the impeller to come to rest.
NB: Care should still be taken however since airflow generated at some other point in the system can cause the impeller to "windmill" even when power is not present.</p> <p>8.5 Care should be taken when removing and storing access panels in windy conditions.</p> |
|---|--|