

AXUS IFC

300°C & 400°C for 2hr

High Temperature Impulse Axial Fans Installation and Maintenance



1.0 Introduction

The Nuaire IFC impulse unit comprises a high temperature axial fan with specially designed inlet and outlet attenuators which, comes completely assembled unit with mounting brackets, fan guard and deflector plate.

Fan Coding Descriptions

IFC8-31
| | |
1 2 3

1. AXUS IFC Fan
2. No Suffix - 300°C for 2hrs
8 - 400°C for 2 hrs
3. Case Size (cm)

The Nuaire IFC unit is built up of fan/motor assembly, inlet & outlet silencers, mounting brackets, finger guard and deflector plate shall be certified for high temperature operation at 300°C or 400°C for 2 hours, the range shall have been type tested to EN12101-3.

Units shall be 2 speed or inverter driven, providing, low speed for day to day environmental ventilation and one off operation for emergency ventilation (S1 duty). They shall also be suitable for reversible operation.

Fully reversible options (i.e. similar duty in both airflow directions) are available, please contact Nuaire for details.

The unit shall have a unique mounting system, which shall enable the unit to be positioned as a "first fix", avoiding possible mechanical damage.

The Nuaire IFC unit shall have inlet guards for safety purposes and also to prevent debris being pulled through the fan. It also has a specially designed airflow deflector to direct the jet stream from the fan at the required angle sufficient to overcome the natural buoyancy effect of the smoke.

EN12101-3 compliant, refer to EC certificate of conformity, 0086-CPR-672476.

2.0 Handling

Always handle the units carefully to avoid damage and distortion. If mechanical aids are used to lift the unit, spreaders should be employed and positioned so as to prevent the slings, webbing etc. making contact with the casing.

Figure 1. Typical Delivery

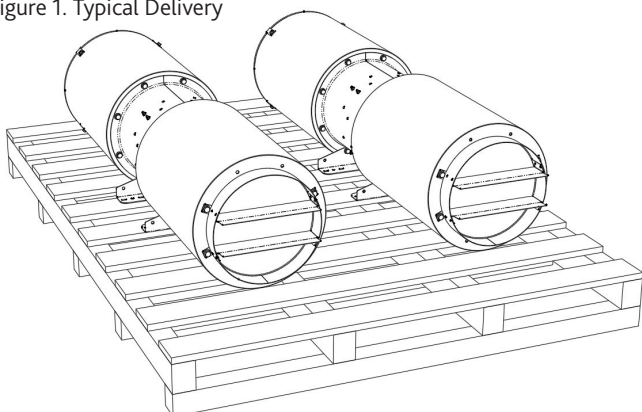

3.0 Installation

Installation must be carried out by competent personnel in accordance with the appropriate authority and conforming to all statutory governing regulations.

3.1 Fixing the IFC Unit to the Ceiling

The support brackets are included and come fitted to the unit. The unit needs to be carefully raised into position and using appropriate fixings attached to the ceiling. It is essential to check the unit is firmly fixed and able to take the weight of the IFC unit (max 60kg).

Figure 2. Mounting Points

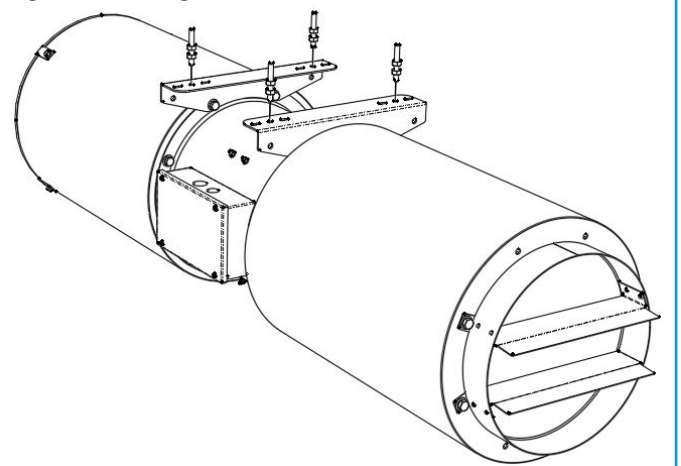

3.2 Dimensions (mm)

Unit	Dimensions (A x B x C)	Weight (kg)
IFC-31	1740 x 445 x 390*	43
IFC-35	1755 x 445 x 456*	48
IFC-40	1815 x 505 x 501*	58

Figure 3. Unit Dimensions

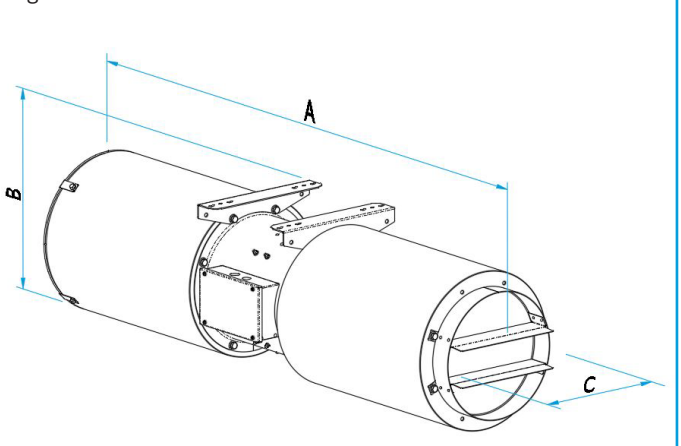

4.0 Electrical Information

Motors are totally enclosed and protected to IP55 (Dust and low pressure water jets). Motors comply with BS5000, EN600034 and IEC34-1. Enclosures are to IP55 with class H insulation. Motors are tested in accordance with EN12101-3.

N.B. Please note the requirements for maintenance of the motor. Failure to comply with the recommendations will invalidate any warranty claim.

4.1 Wiring

Electrical supply wiring connection is to an externally mounted terminal box on the case exterior. The box is pre-wired to the motor with heat resisting cable.

N.B. If a two speed starter is used it must have 3 contactors. Individual wiring diagrams are included with each unit.

A matched Nuair Inverter Speed Control is available. Please contact Nuair.

Two speed 3 phase TAP/PAM wound motors (DOL starting both speeds).

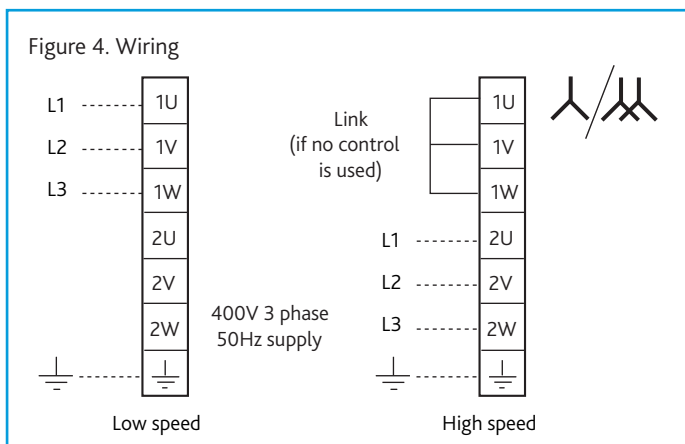

4.2 Connection Details

Check that the voltage full load and starting current on the fan rating label is suitable for your supply.

4.3 Two Speed Motors

Two speed motors are supplied TAP or PAM single winding. All two speed types are designed for Direct-On-Line (DOL) starting on both speeds only unless otherwise specified

N.B. TAP wound motors require a three contactor control. Individual wiring instructions are included with each unit.

4.4 Start Up Procedure

Ensure that the impeller rotation follows the label arrow indicator on the casing. Should the direction be incorrect on three phase units, reverse any two of the supply leads. Care should be taken to set correct rotation as incorrect rotation may result in damage to the motor. Equipment should be run for approx. 30 minutes to ensure correct operation. If any fault occurs, the equipment should be switched off. Do not re-start until the fault has been rectified.

5.0 Maintenance

5.1 General

Nuair recommends all products maintained in accordance with the HVAC "Standard Maintenance Specification for Mechanical Services in Buildings" - Volume II Ventilating and Air Conditioning. For guidance only due to the different periods of operation from the time of installation and conditions of use, no rigid inspection and maintenance periods can be recommended.

We suggest, therefore that the inspection and if necessary cleaning should be carried out at regular intervals of 1000 hours of operation or 3 months, whichever is the sooner. For a routine inspection, check the tightness of all nuts, keys, grub screws and end bolts etc. Remove any build-up of dirt or dust with a brush.

5.2 Motors

Ongoing maintenance - Induction motors, by their very nature require minimal maintenance. However, a regular regime of inspection is recommended to ensure minor problems do not escalate into breakdowns. Typical intervals would be 1000 hours of operation or 3 months, whichever is the sooner.

5.3 Checklist

- No visible damage i.e. impeller cracked, fan cowl bent, foot cracked etc.
- No accumulation of dust or fibres on the frame or around the fan inlet.
- No significant corrosion of the lifting lugs/eye bolts.
- No excessive vibration.
- No loose fasteners.
- Cables and earth's are sound.
- Motor and gland plate seals are in good condition.
- Insulation resistance adequate, imperative this is checked after prolonged shut down.

IMPORTANT

For good EMC engineering practice, any sensor cables or switched live cables should not be placed within 50mm of other cables or on the same metal cable tray as other cables.

6.0 Specific Commissioning and Servicing Requirements

Motors for Smoke Extract Fans

Exposure temperature/time: 300°C for 2 hours / 400°C for 2 hours

These motors are used to provide a SAFETY FUNCTION for people in the event of fire in public premises or in the home: they are therefore subject to strict constraints concerning their operating and maintenance.

Operating Constraints

- i. Check on the nameplate that the selected motor corresponds to the maximum exposure temperature and duration.
- ii. Non ventilated motors MUST be placed in the airflow from the driven fan. Ventilated motors can be placed outside the flow.
- iii. AFTER THE MOTOR HAS BEEN SUBJECTED TO ONE EMERGENCY DUTY OPERATION, IT MUST BE REPLACED.
- iv. With variable speed control. Ensure that the maximum speed never exceeds the speed of the motor supplied by the mains and that the delivered power corresponds to the previous definitions.

These qualifications ensure the qualification of the driven fan by the manufacturer.

Maintenance Constraints

Regular service visits must be performed on the installation AT LEAST EVERY 6 MONTHS, incorporating the following checks:

i. Checking insulation resistance ($R > 100 \text{ MOhms}$, 500V DC)

- If the drain holes are blocked, open them to eliminate any accumulated condensation.
- If $R < 100 \text{ MOhms}$, dry the stator in an oven and check the insulation resistance. If the fault persists, replace the stator.
- The stator must be replaced 5 years after installation or after 20,000 hours of operation.

ii. Cooling check

- Ensure there is no dust or grease in the entire ventilation circuit (housing fins, motor cover/fan if fitted driven fan).
- Ensure the motor runs normally when switched on for a few minutes.

iii. Bearing check (C3 or C4 play)

Run the motor during each maintenance visit. When the motor is cold, a high level of noise is caused by the texture of the grease. This does not indicate a bearing fault.

S2 duty only:

The bearings must be replaced by an identical type every 5 years. Ensure the motor runs normally when switched on for a few minutes.

iv. Fixing Check

During regular maintenance, check all fixtures and fittings to ensure they have remained secure and in good working order.

S1 duty and Emergency in S2 duty:

a) Permanently greased bearings.

300°C or 400°C range; replace on 2 pole motors after 10,000 hours of operation and on motors with 4 poles or more after 20,000 hours.

b) Regreaseable bearings

The information on the motor nameplates must be strictly respected (grease quantity, grease quality and regreasing frequency). The bearings must be replaced after 20,000 hours of operation.

7.0 Replacement of Parts

When ordering spares it is important to state the unit serial number to ensure that the correct spares will be supplied.

N.B. Fixing bolts, nuts, studs, screws, spacers or washers are not included with these parts and if required, should be clearly specified on the order in addition to the part description number.

8.0 Warranty

The three year warranty starts from the day of delivery and includes parts and labour for the first year. The labour element is subject to full, free and safe access to the equipment as recommended by the CDM regulations. The remaining two years covers replacement parts only.

This warranty is void if the equipment is modified without authorisation, is incorrectly applied, misused, disassembled, or not installed, commissioned and maintained in accordance with the details contained in this manual and general good practice.

The product warranty applies to the UK mainland and in accordance with Clause 14 of our Conditions of Sale. Customers purchasing from outside of the UK should contact Nuair International Sales office for further details.

9.0 After Sales

Please contact Nuair: A Trading Division of Polypipe Limited, for information on any aspects of the motor performance that may need clarification. Contact must be made prior to any remedial action being taken under the warranty.

Please quote the motor serial number in all such cases with detailed description of the problem.

For technical assistance or further product information, including spare parts and replacement components, please contact the After Sales Department.

Telephone 02920 858 400
aftersales@nuair.co.uk

Technical or commercial considerations may, from time to time, make it necessary to alter the design, performance and dimensions of equipment and the right is reserved to make such changes without prior notice.