



MRXBOXAB-ECO-LP2SW (Standard Unit)

MRXBOXAB-ECO-LP2OHSW (Opposite Hand Unit)

Mechanical Ventilation Unit with Heat Recovery for
Ceiling Void Mounting

Installation and Maintenance



1.0 SAFETY INFORMATION

- The provision of the electrical supply and the connection of the unit to the mains must be carried out by a qualified electrician.
- Isolate from power supply before removing any covers. During installation/ maintenance ensure all covers are fitted before switching on the mains supply.
- Disconnection from the supply mains must be incorporated within the fixed wiring in accordance with the wiring regulations and shall have a minimum contact separation of 3mm in accordance with the latest edition of the IEE Wiring Regulations.
- During installation / maintenance ensure all covers are fitted before switching on the mains supply.
- Precautions must be taken to avoid the back-flow of gases into the room from the open flue of gas or other fuel-burning appliances.
- This appliance can be used by children aged from 8 years and above and persons with reduced physical, sensory or mental capabilities or lack of experience and knowledge if they have been given supervision or instruction concerning use of the appliance in a safe way and understand the hazards involved. Children shall not play with the appliance. Cleaning and user maintenance shall not be made by children without supervision.
- If the supply cord is damaged, it must be replaced by the manufacturer, its service agent or similarly qualified persons in order to avoid a hazard.
- Ducting must be securely fixed with screws to the spigot to prevent access to live parts.

2.0 INTRODUCTION

The LP2 ceiling void mounted unit is designed to provide mechanical supply and extract ventilation with heat recovery and incorporates HX bypass.

The unit is fitted with two independent fans. Each fan has full speed control for background and boost ventilation rates. To recover heat from the extract air the heat exchanger block is utilised. The heat exchanger can recover up to 80% of the normally wasted heat.

IMPORTANT

The unit must remain switched on at all times to maintain ventilation within the dwelling. Turning the unit off will cause long term damage to the unit and building fabric.

This appliance is not intended for use by persons (including children) with reduced physical, sensory or mental capabilities, or lack of experience and knowledge, unless they have been given supervision or instruction concerning the use of the appliance by a person for their safety. Children should be supervised so that they do not play with the appliance.

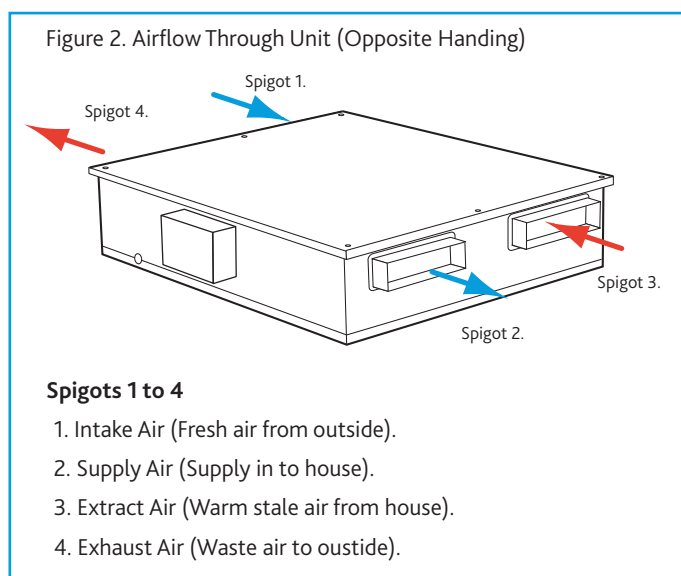
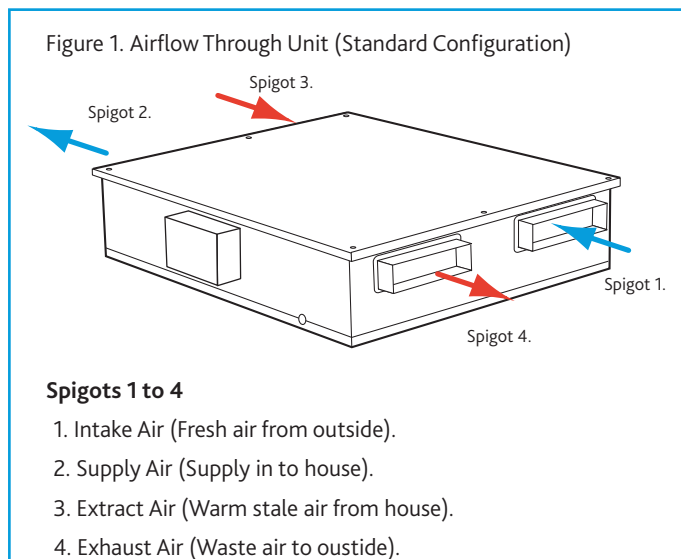

3.0 INSTALLATION

Installation must be carried out by competent personnel in accordance with the appropriate authority and conforming to all statutory governing regulations. All mains wiring must be in accordance with the current I.E.E. Regulations, or the appropriate standards. Ensure that the mains supply (Voltage, Frequency and Phase) complies with the rating label.

Please note a clear working space is required around the installed unit to allow the cover to be removed and provide sufficient access for maintenance such as filter change.

The fan must be installed indoors, in a suitable ceiling void away from direct sources of frost, heat, water spray or moisture generation. For a vibration-free result the unit must be mounted to a solid surface in the void.

The unit is designed for ceiling mounting only (Horizontal surface).

The unit is supplied with a steel mounting bracket.

Position & secure the steel bracket to the ceiling using appropriate fixings (supplied by others), ensuring that the two outer fixing holes on the unit are accessible (see fig. 2).

Note: The mounting bracket should be on the same side as the condensate take off.

3. The unit can now be offered into position & located into the mounting bracket.

4. Using appropriate fixings (supplied by others) fix the unit to the ceiling. It is recommended that the unit is fixed through three holes on the non-bracket side and the two outer holes on the bracket side.

Note: The unit must be installed in an upright position as shown for the condensate drain and for compliance with safety regulations relating to IP protection for water drip ingress.

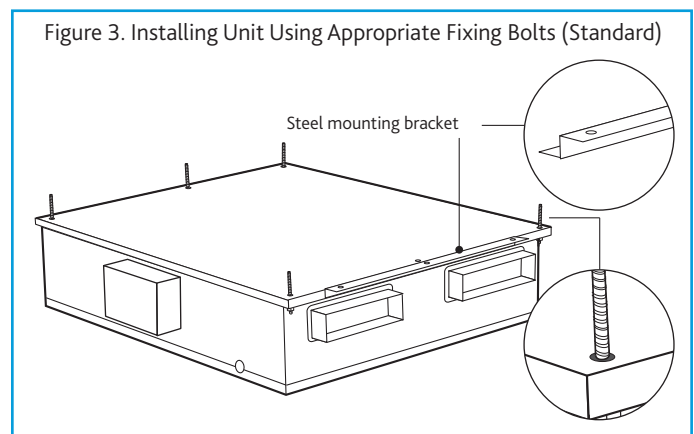

IMPORTANT

Isolation - Before commencing work, make sure that the unit, switched live and Nuaire control are electrically isolated from the mains supply and switched live supply.

Figure 4. Typical Side View Example of Unit (Standard) Mounted in Ceiling Void Using 204 x 60mm Rectangular Ducting and Air Valves

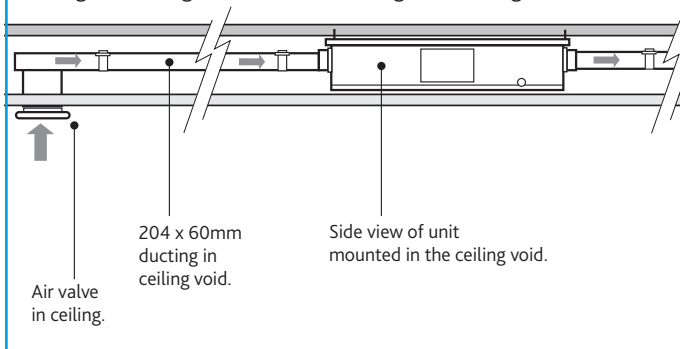

3.1 Condensate Drain Installation

- Unit comes complete with external drain pipe (21.5mm waste pipe). Use conventional plumbing connections to link up with U-trap, detachable compression fit connections are recommended to allow removal of condensate tray for maintenance of the heat exchanger.
- This condensate discharge connection is suitable for 21.5mm diameter overflow pipe.
- If using a U-trap please ensure the U-trap has been filled to a suitable level of water to avoid any air locks.
- If the condensation pipe is fitted in an unheated space the pipe should be insulated to prevent freezing.

Nuaire recommend MVHR-DRAIN be used as the primary condensate take-off (see fig. 5 and 6).

Figure 5. MVHR-DRAIN Condensate Drain, Running to SVP (Standard Unit)

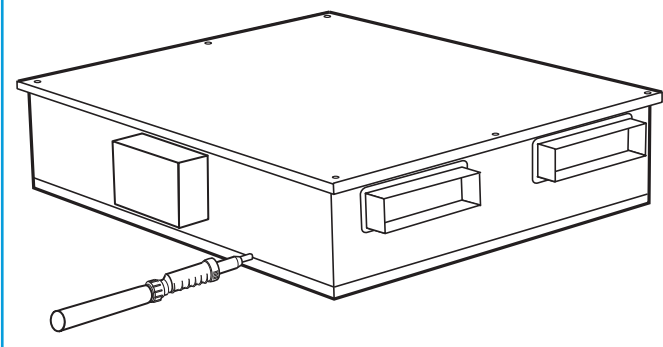
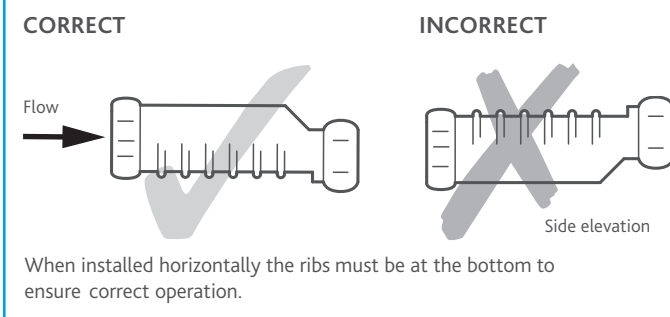

Figure 6. MVHR-DRAIN Correct Installation



3.1 Fixing

Offer up the MVHR-DRAIN inlet to the threaded tail of the appliance waste outlet or MVHR-DRAIN knuckle or running adaptor, and tighten the threaded cap sufficiently hand-tight to provide a water-tight seal (check that the cap screws on square and does not 'cross-thread'). When the screwed cap is tight, the MVHR-DRAIN body is secure.

- Cut the pipe to length, allowing for the full compression socket depth (using an appropriate pipe cutter, such as a Hepworth ratchet pipe cutter).
- Remove any 'swarf' from the end of the plastic pipe. Ream the copper pipe end to remove any 'burr', and file if necessary to remove any external sharp edges. Mark the socket depth on the pipe, and check that the pipe section to be jointed is free of any surface damage which may affect the joint seal.
- Unscrew the cap from the MVHR-DRAIN outlet, and slide the cap and rubber seal onto the pipe.
- Insert the pipe end fully into the socket.
- Slide the rubber seal and screwed cap up against the face of the socket, and tighten the cap sufficiently hand-tight (check that the cap is square to the body and does not 'cross thread'). Hand tight should be adequate to form a proper seal.

3.2 Extract/Input Areas

The unit is designed to extract air from all wet rooms e.g. bathroom, kitchen, en-suite, utility room (with sink).

WC's do not need to be ventilated if openable windows are fitted.

Supply air should be to all habitable rooms e.g. bedrooms and lounge. Extract / input grilles should be adjustable valve types (not supplied).

External grilles must have a minimum free area of 12,250 mm².

3.3 Ducting

Before commencing ducting installation reference should be made to building regulations document "Domestic ventilation compliance guide". This document supports ADF2010 and details installation, testing and commissioning of all ventilation systems.

It is recommended that rigid ducting must be used it all times. Flexible ducting has a very high resistance and it is impossible to calculate how much resistance will be on a system if used. If used the flexible ducting must be kept to a minimum and should always be pulled taut. A maximum of 300mm should be used on each leg.

To prevent condensation on the outside of the outside air inlet duct and the air outlet duct from the MRXBOXAB-ECO-LP2, these ducts should be insulated.

Ducting must be installed in such a way that resistance to airflow is minimised. Bends should be kept to a minimum.

A minimum distance of 300mm between the appliance and any bends in ductwork is recommended.

204 x 60mm rectangular ducting should be used. (Refer to dwelling ducting design drawing, figure 6 on page 4 for further information).

Ducting joints must be sealed with silicone type sealant and needs to be taped. Ducting shall be adequately and reliably fixed to the appliance.

3.4 Ventilation Flow Rates

Table 1. ADF 2010 - Extract ventilation rates.

Room	Min high rate	Min low rate
Kitchen	13 l/s	Total extract rate should be at least the whole dwelling ventilation rate given in table 2.
Utility Room	8 l/s	
Bathroom	8 l/s	
Sanitary Accommodation	6 l/s	

Table 2. Whole dwelling ventilation rates.

	Number of bedrooms in dwelling				
	1	2	3	4	5
Whole dwelling ventilation rate (l/s) <small>1,2</small>	13	17	21	25	29

Notes:

- 1. In addition, the minimum ventilation rate should be no less than 0.3 l/s per m² of internal floor area. (This includes all floors, e.g. for a two-story building add the ground and first floor areas).**
- 2. This is based on two occupants in the main bedroom and a single occupant in all other bedrooms. This should be used as the default value. If a greater level of occupancy is expected add 4 l/s per occupant.**

3.5 ADF 2010 Ventilation Calculations Design of MVHR Systems

The MVHR system has been sized for the winter period. Additional ventilation may be required during the warmer months and it has been assumed that the provisions for purge ventilation (e.g. openable windows) could be used.

Step 1: For any design air permeability, determine the whole dwelling ventilation supply rate from **Table 2**.

As an alternative where the design air permeability is intended to be leakier than (>) 5m³/(h.m²) 50 Pa, allow for infiltration for all dwelling types by subtracting from the whole dwelling ventilation supply rate from Table 2; 0.04 x gross internal volume of the dwelling heated space (m³).

Step 2: Calculate the whole dwelling extract ventilation rate by summing the individual room rates for 'minimum high rate' from **Table 1**. (For sanitary accommodation only, as an alternative, the purge ventilation provisions given in ADF 2010 can be used where security is not an issue. In this case 'minimum high extract rate' for the sanitary accommodation should be omitted from the step 2 calculation).

Step 3: The required airflow rates are as follows:

The maximum whole dwelling extract ventilation rate (e.g. boost) should be at least the greater of step 1 and step 2.

Note that the maximum individual room extract rate should be at least those given in **table 1** for minimum high rate.

The minimum air supply rate should be at least the whole building ventilation rate found in step 1.

For Scotland refer to BRE Digest 398.

For further information refer to the "Domestic Ventilation Compliance Guide".

IMPORTANT

Any air intake terminal **MUST** be installed in accordance with the appropriate regulation.

As a guide, the BS5440 series of British Standards deals with this issue and currently states that an air intake must be at a minimum distance of 300mm from a gas boiler balanced flue.

Installers are advised to be aware of the requirements of this standard when installing 'through the wall' supply air ducting.

Pre Commissioning MRXBOXAB MVHR Units

MRXBOXAB units are designed to ventilate the whole dwelling and must not be used during site construction or the clean-up period. Cement and plaster dust can be abrasive and can affect fan performance and reliability. Please ensure that the filters are checked prior to commissioning to ensure there is no build-up of dust or debris.

While the property is drying out, very high moisture levels are likely to occur. Therefore it is advisable that if the installation and building works are complete the unit is left running. If the building works are not complete please close the air valves or cover up the air valves to prevent condensation forming in the ductwork and the MRXBOXAB unit due to natural migration of warm air.

4.0 DIMENSIONS (mm) STANDARD CONFIGURATION

Figure 7. Dimensions & Access Requirements (Standard)

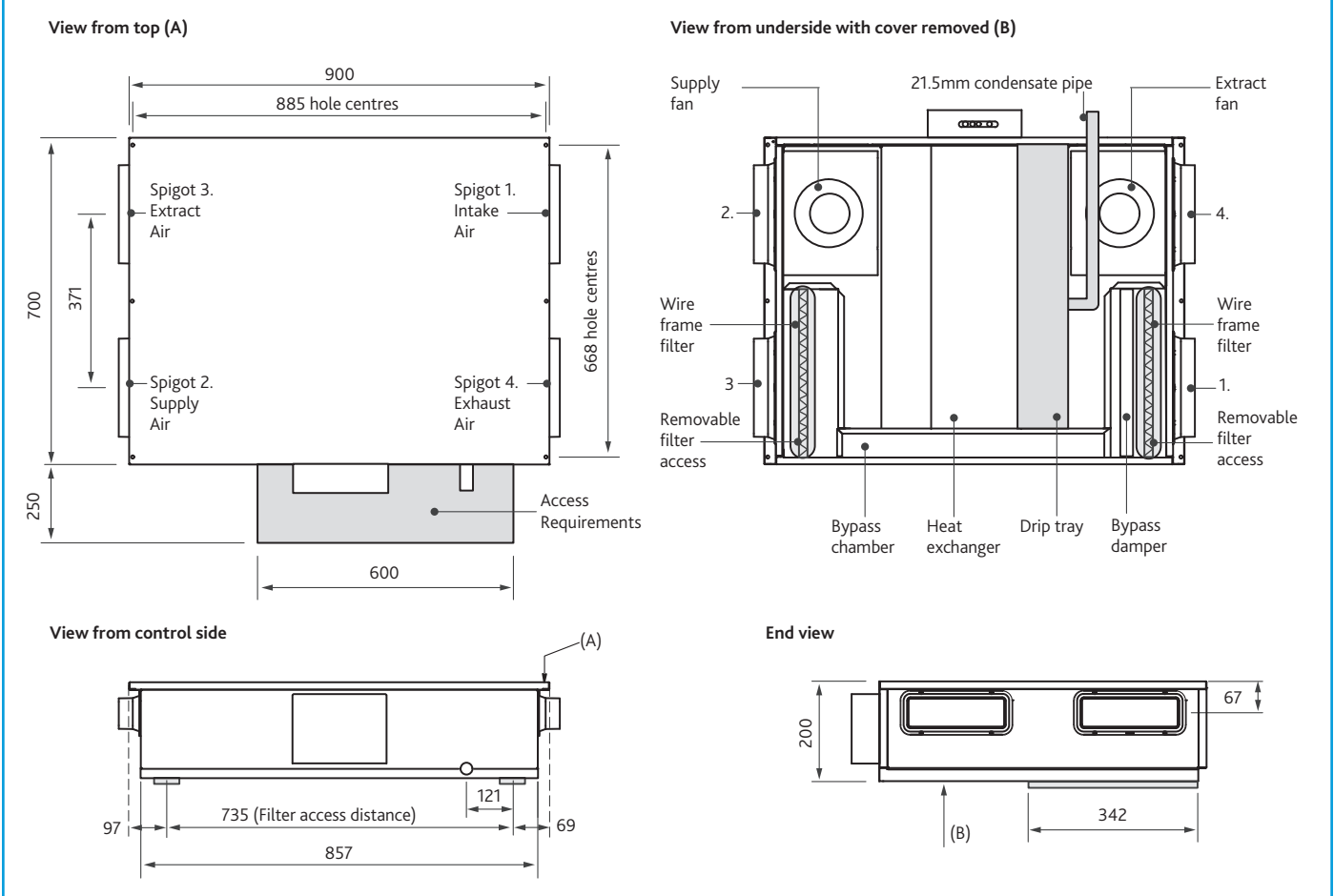

5.0 DUCTING ARRANGEMENTS, STANDARD CONFIGURATION

Figure 8. Typical Ducted Arrangement for a Void Mounted Unit (Standard) Using Rectangular 220 x 90mm Ducting and Ceiling Air Valves

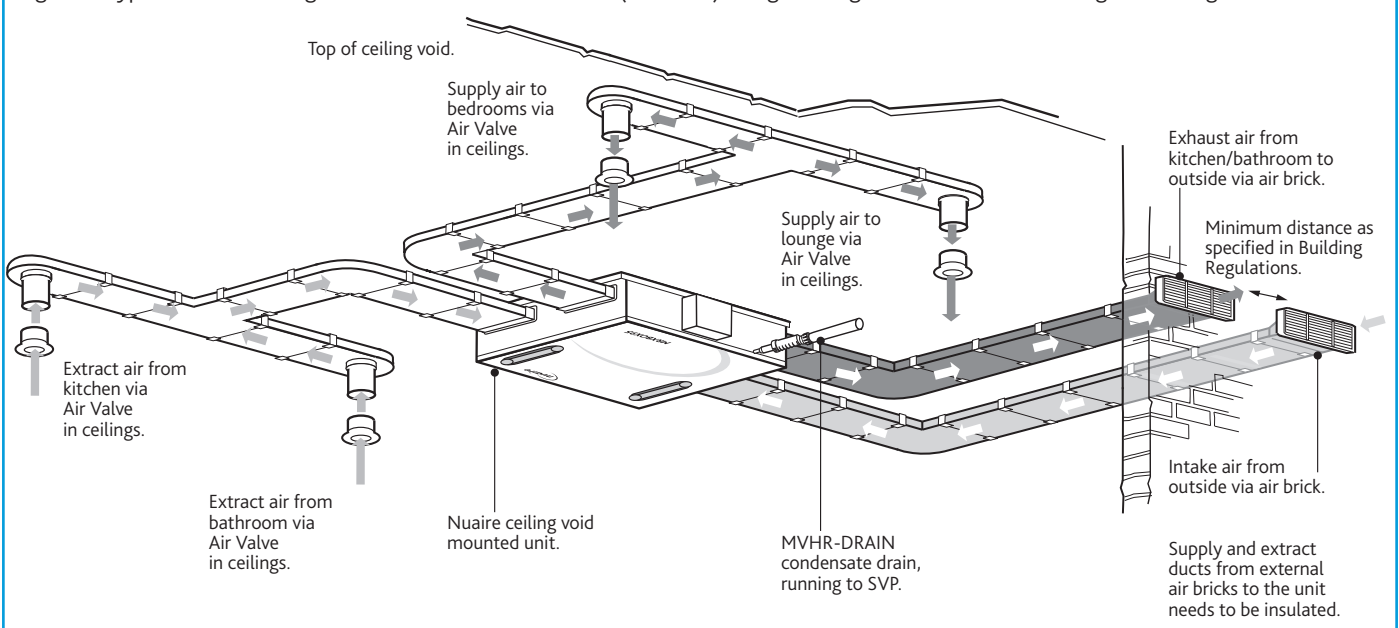

6.0 DIMENSIONS (mm) OPPOSITE HAND CONFIGURATION

Figure 9. Dimensions & Access Requirements (Opposite Hand Unit)

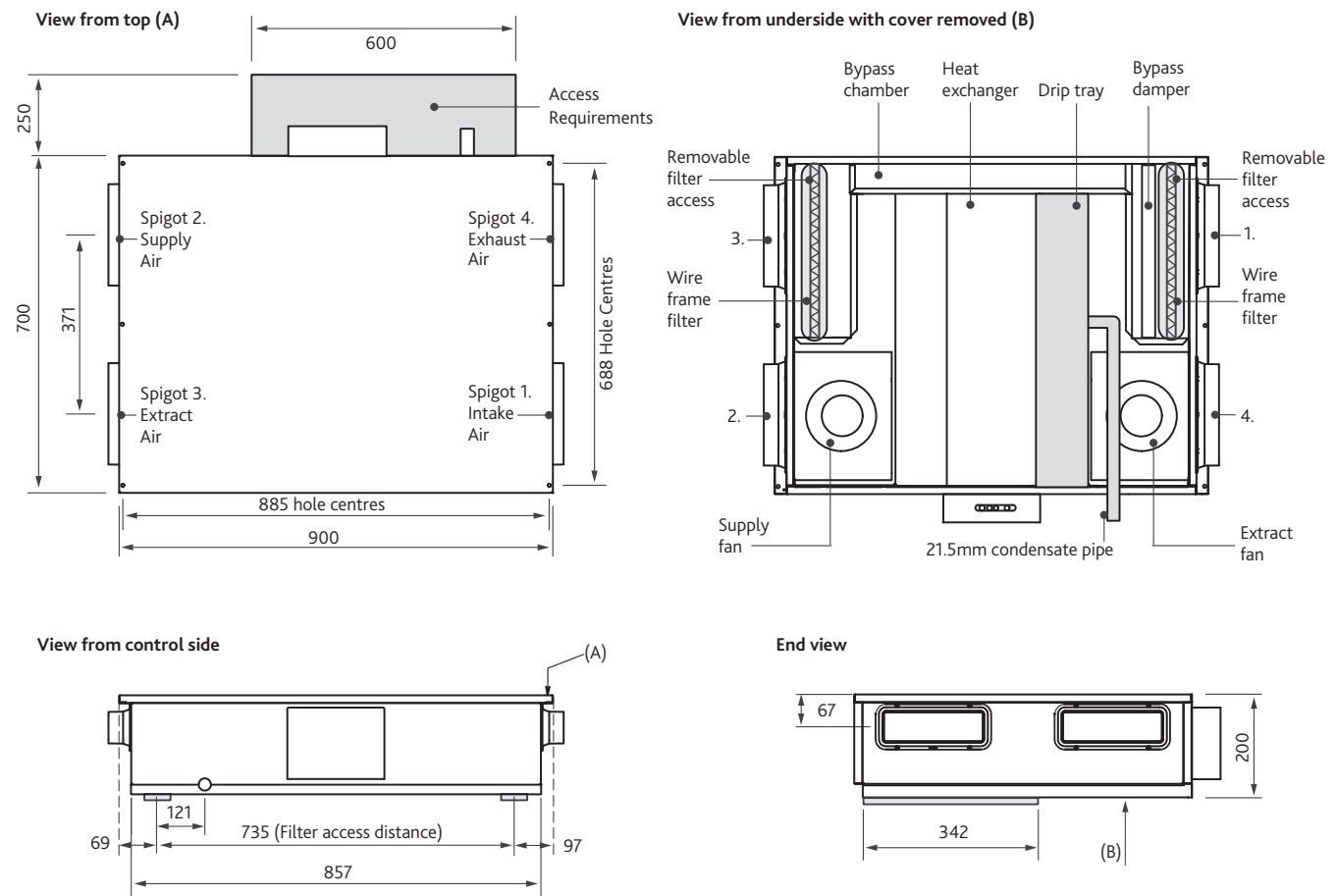

7.0 DUCTING ARRANGEMENTS, OPPOSITE HAND CONFIGURATION

Figure 10. Typical Ducted Arrangement for a Void Mounted Unit (Opposite Hand) Using Rectangular 220 x 90mm Ducting and Ceiling Air Valves

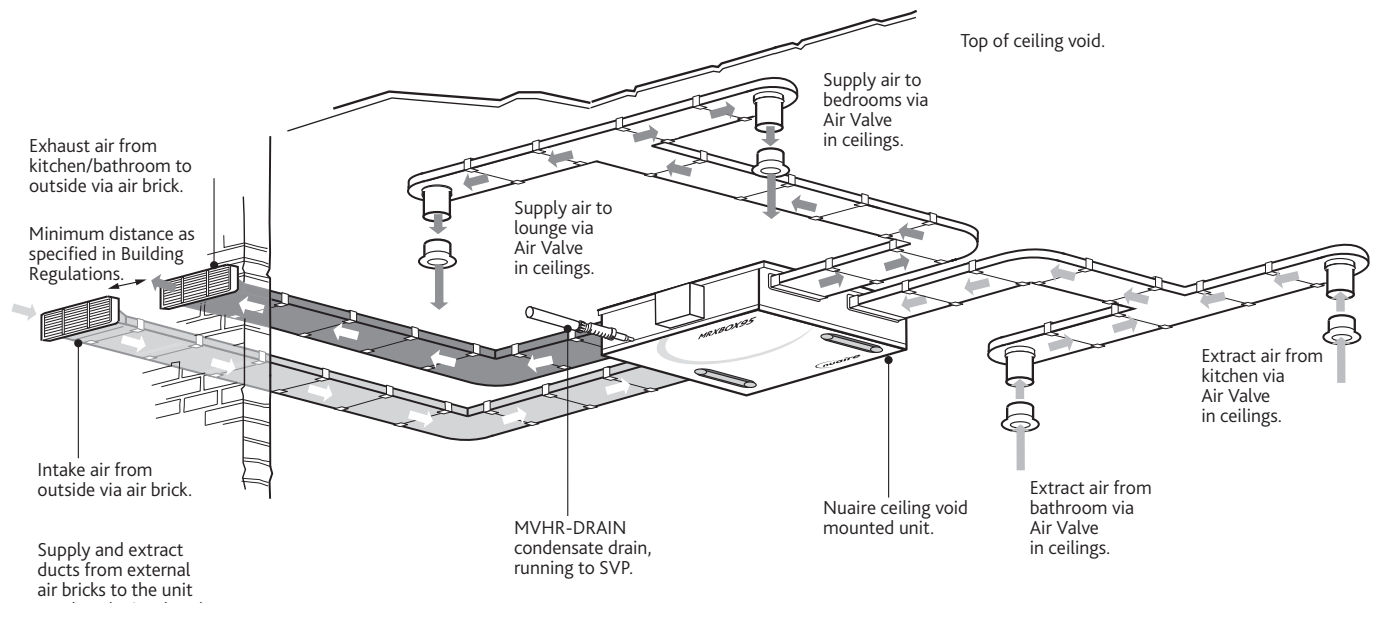

8.0 ELECTRICAL CONNECTION

Figure 11. PCB Details

IMPORTANT

For good EMC engineering practice, any sensor cables or switched live cables should not be placed within 50mm of other cables or on the same metal cable tray as other cables.

Please note: the electrical connection of the unit must be carried out by a qualified electrician. The unit is supplied with a flexible cord for connection to the mains supply.

Electrical details:-
Voltage: 240V 1ph 50Hz
Consumption: LP2 - 1.3 Amps
Fuse rating: 3 Amps

NOTE: This unit must be earthed.
The cable from the mains power supply should be connected to a fixed wiring installation, via a fused isolator, in accordance with current IEE wiring regulations.

Note: Wiring is for reference purposes only as the connections above are factory fitted.

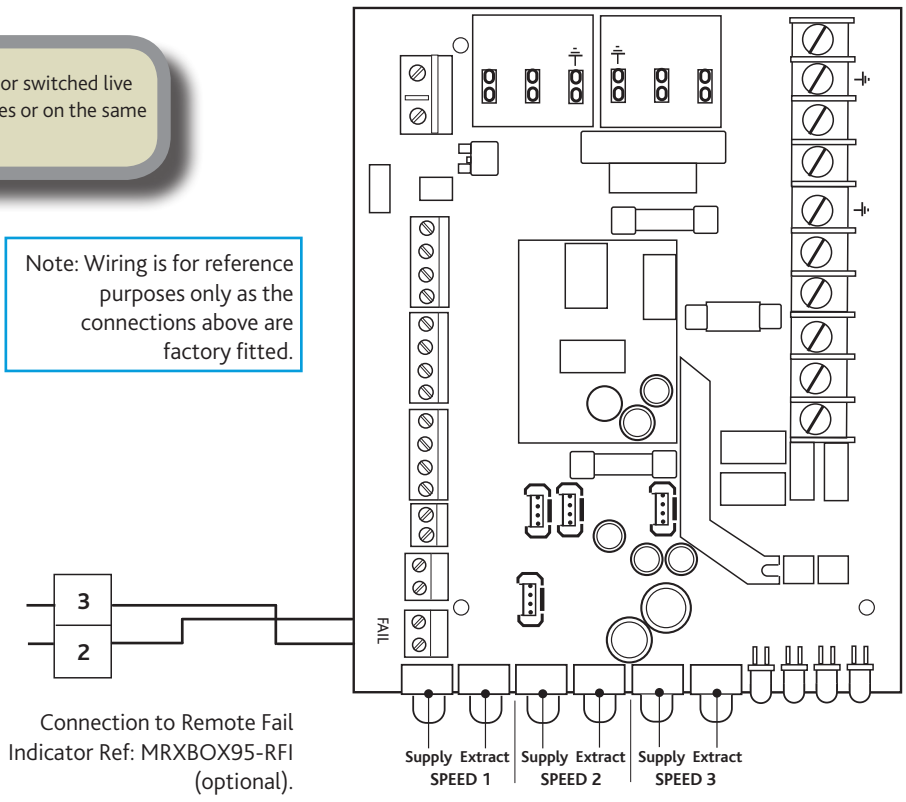

Connection to Remote Fail Indicator Ref: MRXBOX95-RFI (optional).

8.1 Examples of Typical Wiring Layouts

Unit serving kitchen and bathroom

Disconnection from the supply mains must be incorporated within the fixed wiring in accordance with the wiring regulations and shall have a minimum contact separation of 3mm.

Figure 12.

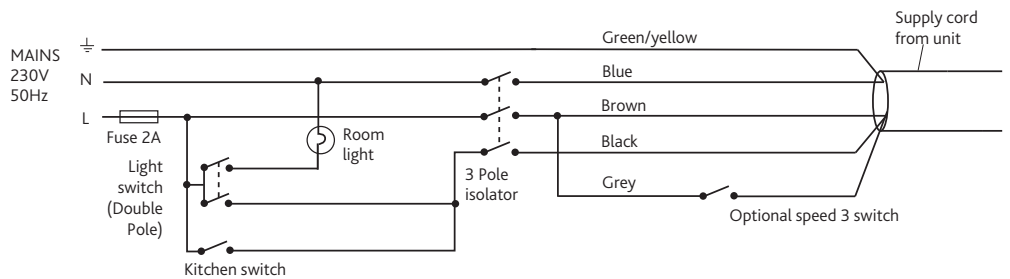

Unit serving kitchen and two bathrooms

Disconnection from the supply mains must be incorporated within the fixed wiring in accordance with the wiring regulations and shall have a minimum contact separation of 3mm.

Figure 13.

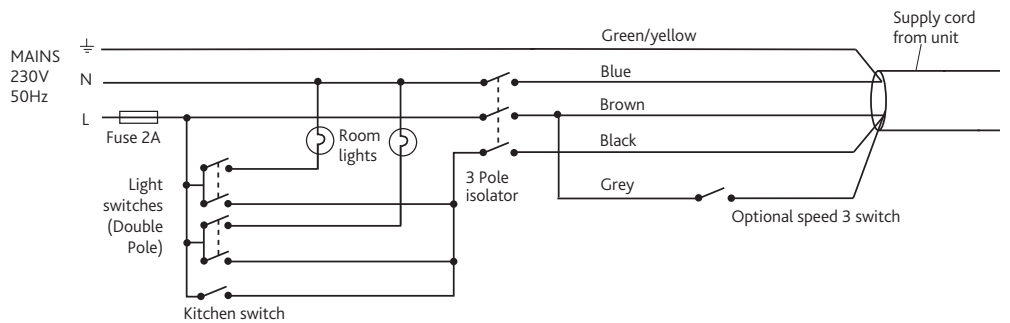

Connection of summer/winter switch

Figure 14.



Volt free Summer / Winter Switch (supplied with unit)
 Polarity is inconsequential
Warning! - Do not connect to mains!

8.2 Optional Controls For further information contact Nuair on 02920 858 400.

9.0 COMMISSIONING

IMPORTANT

The filters fitted inside the unit are protected with a plastic film. Prior to commissioning remove the covers (fig. 13), take off the film and replace.

1. For the required air flow rates please refer to the design specification for the property, follow 2.4, or refer to building regulations ADF 2010.
2. The unit is supplied with independent control for both normal and boost airflows. (see fig. 10).
3. Correct commissioning is essential to ensure the ventilation air flowrates are met. It also ensures the unit is not over ventilating and causing excessive power consumption.
4. Commissioning should be carried out in accordance with building regulations document "Domestic ventilation compliance guide".

A calibrated moving vane anemometer and hood will be required to carry out commissioning.
5. Adjustment valves should be locked in place to prevent further adjustment.
6. Once commissioned the home owner / tenant should be informed that the unit should not be adjusted as it will have a detrimental effect on the indoor air quality and could result in condensation and mould growth. The label covering the control has an adhesive panel which should be removed post commissioning to prevent tampering.

Figure 15. PCB inside enclosure.

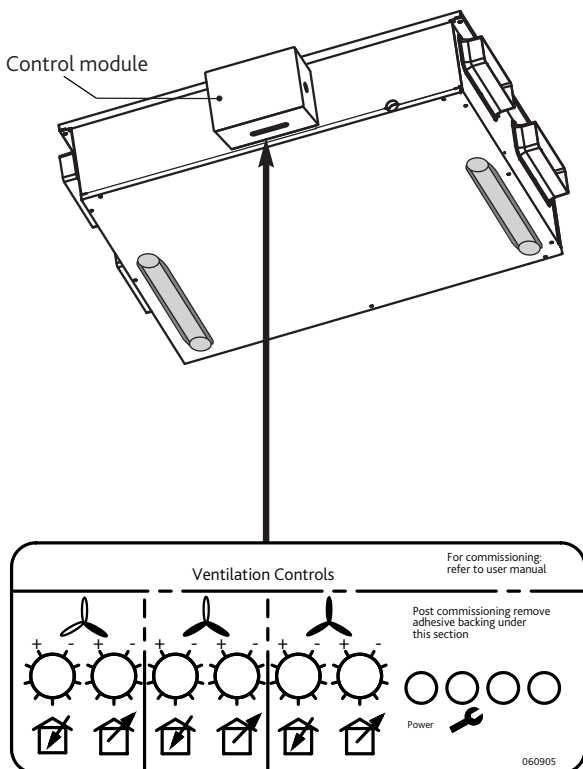

10.0 STATUS INDICATION

The status of the unit is indicated by a series of LED's on the control box cover. The variants are listed below.

Speed 1	●	○	○	○
Speed 2	●	○	☀	○
Speed 3	●	○	☀	○
Supply Fan Fault	●	●	○	○
Extract Fan Fault	●	●	○	○
Frost Protection	●	○	☀	☀
Filter Change	●	○	○	☀
HX Bypass (AB units only)	●	○	☀	☀

Note: The display on the unit control panel will not indicate when a higher speed setting has been triggered by an external source, such as an ES-PIR2 etc.

10.1 Integral automatic HX bypass (AB units only)

Intake and extract temperatures are monitored at the point the airflows enter the unit, if the range falls within the set parameters the bypass damper is opened automatically to target an indoor comfort temperature all year round.

10.2 Summer / Winter Switch

When the switch position is set to Summer, the integral automatic summer bypass is fully operational. In the alternative Winter position, the HX bypass is disabled to ensure the unit is constantly in heat recovery mode.

10.3 Frost Protection

In the event of the intake air temperature at the unit dropping below the predetermined set point (-5°C as standard) the supply fan will reduce to minimum speed, once the temperature rises above the set point the fan will return to its commissioned speed.

Please note this mode will only activate after ten days of continuous run time. If commissioning of the unit is outside of this timeframe please notify the after sales department prior to site visit.

11.0 MAINTENANCE/CLEANING

We recommend that the two filters are inspected after 6 months, and replaced every 12 to 18 months.

The filters can be removed from the unit by removing the two filter covers on the bottom panel of the unit. Take hold of the two circular tabs either end of the filter covers and pull to remove (see fig. 11).

The filter can now be extracted by pulling the removal loop on the edge of the filter. Once the filters have been inspected return or replace them as necessary.

Inspect the heat exchanger every 5 years. Generally check for damage and security of components. Refit cover.

Figure 16. Remove the two filter covers on the underside panel of the unit, and the filters can be pulled out of the unit using the tab on the lower edge of the filter.

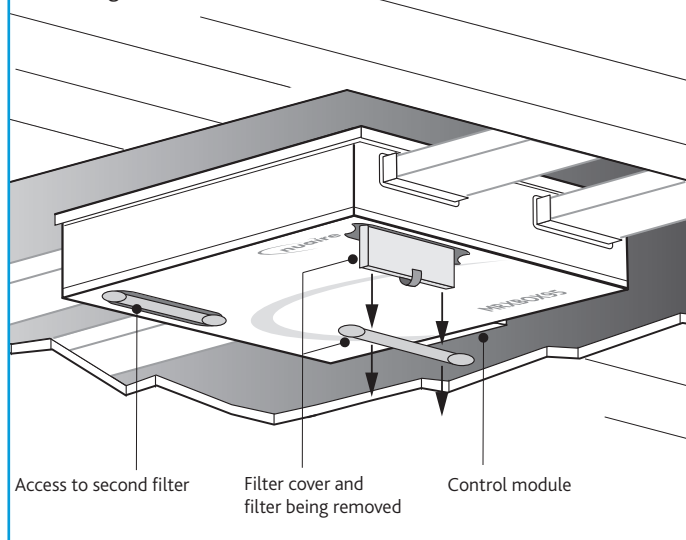

12.0 REPLACEMENT OF PARTS

Nuaire keep extensive stocks for quick delivery, should any component need replacing. Ensure that the unit is electrically isolated, before carrying out any work.

Note: The supply cable must be replaced by an electrically competent person.

When ordering spare parts, please quote the serial number of the unit and the ARC number of the purchase if possible (**this information will be available on the fan label**).

13.0 WARRANTY

The 5 year warranty starts from the day of delivery and includes parts and labour for the first year and parts only for the remaining 4 years. This warranty is conditional on planned maintenance being undertaken.

This warranty is void if the equipment is modified without authorisation, is incorrectly applied, misused, disassembled, or not installed, commissioned and maintained in accordance with the details contained in this manual and general good practice.

The product warranty applies to the UK mainland and in accordance with Clause 14 of our Conditions of Sale. Customers purchasing from outside of the UK should contact Nuaire International Sales office for further details.

14.0 AFTER SALES ENQUIRIES

For technical assistance or further product information, including spare parts and replacement components, please contact the After Sales Department.

Telephone 02920 858 400
aftersales@nuaire.co.uk