



## MRXBOXAB-ECO2-AESW (Standard Unit) MRXBOXAB-ECO2-AEOHSW (Opposite hand Unit)

Mechanical Ventilation Units with Heat Recovery for Wall Mounting

# Installation and Maintenance



## 1.0 INTRODUCTION

The ECO2-AE wall mounted range of units are designed to offer improved sound levels and an aesthetically pleasing installation by housing a Mechanical Ventilation with Heat Recovery unit (MVHR) inside an acoustically lined enclosure.

The MVHR unit is fitted with two independent fans. Each fan has full speed control for background and boost ventilation rates. To recover heat from the extract air the heat exchanger block is utilised. The heat exchanger can recover up to 95% of the normally wasted heat.

If the MVHR unit has integral automatic HX bypass (AB models only), the bypass damper shall open automatically via a wax actuator allowing the air to bypass the heat exchanger to deliver fresh filtered air during the warmer months.

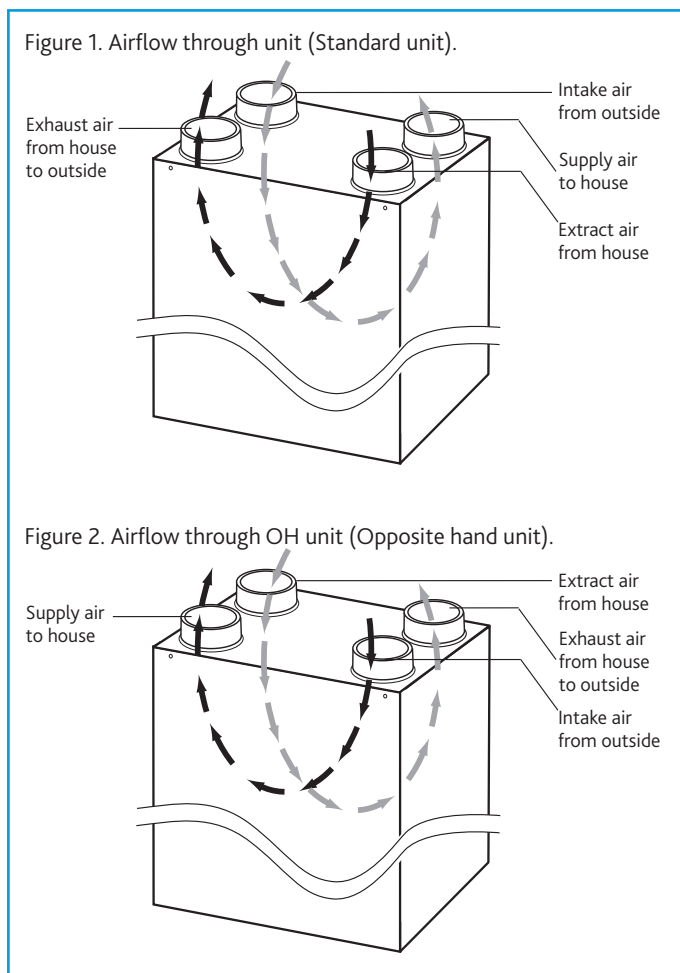

## 2.0 INSTALLATION

Installation must be carried out by competent personnel in accordance with the appropriate authority and conforming to all statutory governing regulations. All mains wiring must be in accordance with the current I.E.E. Regulations, or the appropriate standards. Ensure that the mains supply (Voltage, Frequency and Phase) complies with the rating label.

Please allow a minimum of 350mm in front of the enclosure.

The fan must be installed indoors, on a suitable wall away from direct sources of frost, heat and water spray or moisture generation.

For a vibration-free result the unit must be mounted to a non-reverberant wall.

### 2.1 Transportation fixings

To prevent damage during transportation the product is shipped with securing fixings, these can be found front and centre of the enclosure top panel (fig.3). These must be removed before use, failure to do so will result in excessive vibration and noise. The screws removed can be discarded and replaced with rubber caps provided.

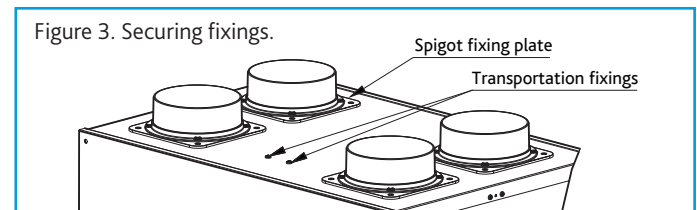

### 2.2 Wall Mounting the MVHR Unit

The unit is designed for wall mounting on a solid wall only, a gypsum block/plasterboard wall will not suffice. Examples of suitable installation are shown overleaf. The wall brackets supplied should be secured to the wall using suitable fixings (supplied by others) as per the dimensions given in fig.4; the head of the chosen fixing should protrude no more than 8mm from the wall bracket. The enclosure assembly can then be lifted using suitable equipment and moved into position so it is sitting directly on the wall brackets (ensuring the rear panel of the enclosure is not in contact with the wall bracket fixings). The enclosure can be secured to the wall brackets using the 4x M8 fixings supplied.

No part of enclosure should be in contact with the building structure, the only components that should be in contact are the wall mounting brackets.

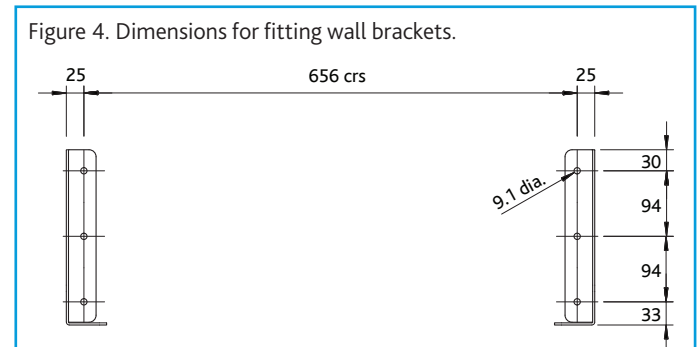

Note: Care must be taken to ensure the unit is installed true in all 3 dimensions. Failure to do so may result in overflow from the internal condensation drip tray.

### IMPORTANT

The unit must remain switched on at all times to maintain ventilation within the dwelling. Turning the unit off will cause long term damage to the unit and building fabric.

This appliance is not intended for use by persons (including children) with reduced physical, sensory or mental capabilities, or lack of experience and knowledge, unless they have been given supervision or instruction concerning the use of the appliance by a person for their safety. Children should be supervised so that they do not play with the appliance.

## 2.3 Option 1: Wall Mounting

The MVHR unit fixed to a solid wall construction using the mounting bracket provided.

Figure 5. Typical example of a cupboard mounted unit (Standard unit) fixed to a block work wall.

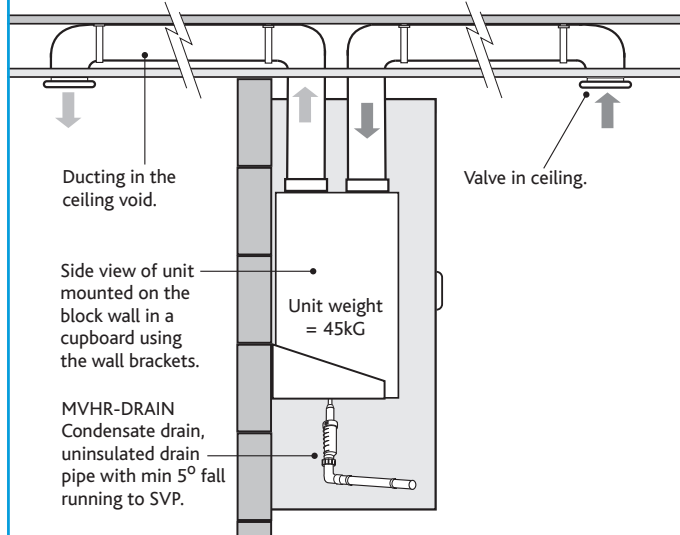

## 2.4 Option 2: Wall Mounting

If it is not practical to use a solid wall, the unit should be fixed to a stud partition with a 25mm minimum thickness MDF panel solidly fixed behind the plasterboard.

If fixing to a stud wall the MDF panel should extend, width wise, over a minimum of 3 vertical studs with centres of no more than 400mm. A vertical stud should be located to correspond with the position each mounting bracket is to be fixed to provide additional support.

Add additional vertical supports if necessary. Height wise, the MDF panel should extend from floor to ceiling.

Fix the mounting bracket to the wall (as fig. 4) and use the wall mounted bracket to mount the unit on (as shown in fig. 6).

Figure 6. Typical example of a cupboard mounted unit (Standard unit) fixed to a stud partition with the MDF panel fixed behind the plasterboard.

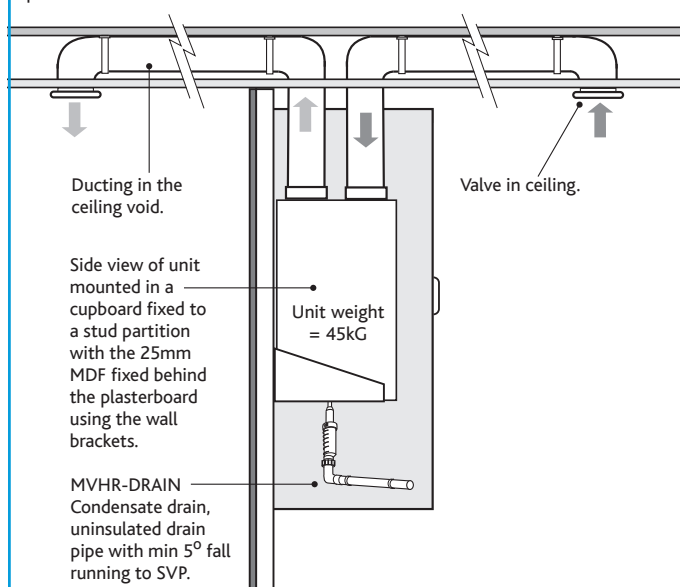

## 2.5 Condensate Drain

The MVHR unit inside the enclosure is fitted with a straight coupling to allow 21.5mm overflow pipe (not supplied) to be attached using solvent cement, the pipe should be passed through the flexible adhesive backed cover plate before the solvent cement is applied.

The pipe can then be inserted into the coupling of the MVHR unit and the cover plate slid along the length to bond against the base panel of the enclosure preventing noise breakout (fig. 7).

Figure 7.

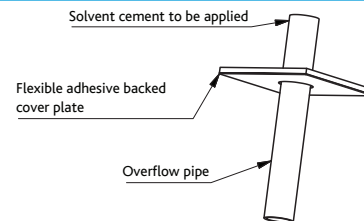

1. The condensate must be discharged under a water level in a U-trap drainpipe or an alternative drain method which acts as an airlock.
2. This condensate discharge connection is suitable for 21.5mm dia. overflow pipe. Solvent cement should be used to make the joint.
3. If using a U-trap please ensure the U-trap has been filled to a suitable level of water to avoid any air locks.
4. If the condensation pipe is fitted in an unheated space the pipe should be in insulated to prevent freezing.

Nuaire recommend MVHR-DRAIN be used as the primary condensate take-off. (see figure 9 and 10).

Figure 8. Wet option:

Condensate pipe connection to unit and a typical example of a "U" trap drainpipe (Standard configuration only).

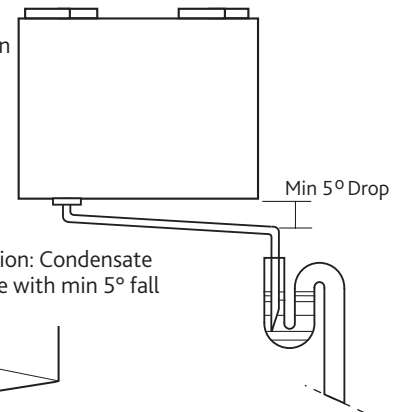
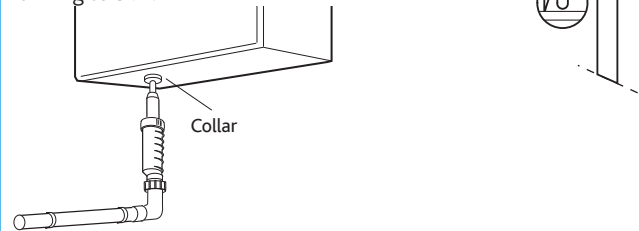
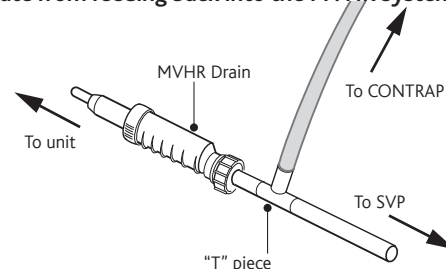

Figure 9. MVHR-DRAIN option: Condensate drain, uninsulated drain pipe with min 5° fall running to SVP.



**Figure 10. IMPORTANT:** When using a "T" Piece to connect the CONTRAP drainage and the MVHR drain pipework the MVHR drain must always be fitted before the "T" Piece to prevent condensate from feeding back into the MVHR system.



## 2.6 Extract/Input Areas

The unit is designed to extract air from all wet rooms e.g. bathroom, kitchen, en-suite, utility room (with sink). WC's do not need to be ventilated if openable windows are fitted.

Supply air should be to all habitable rooms e.g. bedrooms and lounge. Extract / input grilles should be adjustable valve types (not supplied). External grilles are to have a minimum free area of 12,250 mm<sup>2</sup>.

## 2.7 Ducting

Before commencing ducting installation reference should be made to building regulations document "Domestic ventilation compliance guide". This document supports ADF2010 and details installation, testing and commissioning of all ventilation systems.

If the enclosure is to be used in conjunction with an ancillary distribution box (MRXBOX-DB2) refer to additional assembly instructions supplied with the MRXBOX-DB2 as requirements will differ.

Otherwise fit 4x 125mm diameter plastic spigots with the self-tapping screws supplied to the spigot fixings plates found on the top panel of the enclosure, a bead of silicone should be applied to the groove of spigot fixing plate to prevent leakage (see fig. 3).

It is recommended that rigid ducting be used at all times. Flexible ducting has a very high resistance and it is impossible to calculate how much resistance will be on a system if used.

If used the flexible ducting must be kept to a minimum and should always be pulled taut. A maximum of 300mm should be used on each leg.

To prevent condensation on the outside of the outside air inlet duct and the air outlet duct from the unit, these ducts should be insulated.

Ducting must be installed in such a way that resistance to airflow is minimised. Bends should be kept to a minimum.

A minimum distance of 300mm between the appliance and any bends in ductwork is recommended.

Ideally 125mm diameter or 220 x 90mm rectangular ducting should be used. (Refer to dwelling design drawing, figure 10a and 10b on page 5 for further information).

Ducting joints must be sealed with silicone type sealant and shall be adequately and reliably fixed to the appliance.

### IMPORTANT

Any air intake terminal **MUST** be installed in accordance with the appropriate regulation.

As a guide, the BS5440 series of British Standards deals with this issue and currently states that an air intake must be at a minimum distance of 300mm from a gas boiler balanced flue.

Installers are advised to be aware of the requirements of this standard when installing 'through the wall' supply air ducting.

## 2.8 Ventilation Flow Rates

Table 1. ADF 2010 - Extract ventilation rates.

Room	Min high rate	Min low rate
Kitchen	13 l/s	Total extract rate should be at least the whole dwelling ventilation rate given in table 2.
Utility Room	8 l/s	
Bathroom	8 l/s	
Sanitary Accommodation	6 l/s	

Table 2. Whole dwelling ventilation rates.

	Number of bedrooms in dwelling				
	1	2	3	4	5
Whole dwelling ventilation rate (l/s) <small>1,2</small>	13	17	21	25	29

### Notes:

**1. In addition, the minimum ventilation rate should be no less than 0.3 l/s per m<sup>2</sup> of internal floor area. (This includes all floors, e.g. for a two-story building add the ground and first floor areas).**

**2. This is based on two occupants in the main bedroom and a single occupant in all other bedrooms. This should be used as the default value. If a greater level of occupancy is expected add 4 l/s per occupant.**

## Installation and Maintenance

MRXBOXAB-ECO2-AESW Mechanical Ventilation Unit with Heat Recovery

### 2.9 ADF 2010 Ventilation Calculations Design of MVHR Systems

The MVHR system has been sized for the winter period. Additional ventilation may be required during the warmer months and it has been assumed that the provisions for purge ventilation (e.g. openable windows) could be used.

**Step 1:** For any design air permeability, determine the whole dwelling ventilation supply rate from **Table 2**.

As an alternative where the design air permeability is intended to be more than (>) 5m<sup>3</sup>/(h.m<sup>2</sup>) 50 Pa, allow for infiltration for all dwelling types by subtracting from the whole dwelling ventilation supply rate from **Table 2**; 0.04 x gross internal volume of the dwelling heated space (m<sup>3</sup>).

**Step 2:** Calculate the whole dwelling extract ventilation rate by summing the individual room rates for 'minimum high rate' from **Table 1**.

(For sanitary accommodation only, as an alternative, the purge ventilation provisions given in ADF 2010 can be used where security is not an issue. In this case 'minimum high extract rate' for the sanitary accommodation should be omitted from the step 2 calculation).

**Step 3:** The required airflow rates are as follows:

- The maximum whole dwelling extract ventilation rate (e.g. boost) should be at least the greater of step 1 and step 2. Note that the maximum individual room extract rate should be at least those given in **table 1**.
- The minimum air supply rate should be at least the whole building ventilation rate found in step 1.

For Scotland refer to **BRE Digest 398**.

For further information refer to "Domestic Ventilation Compliance Guide" [www.planningportal.gov.uk/buildingregulations/approveddocuments/part1/compliance](http://www.planningportal.gov.uk/buildingregulations/approveddocuments/part1/compliance)

### Pre Commissioning MRXBOX95 MVHR Units

MRXBOX95 units are designed to ventilate the whole dwelling and must not be used during site construction or the clean-up period. Cement and plaster dust can be abrasive and can affect fan performance and reliability. Please ensure that the filters are checked prior to commissioning to ensure there is no build-up of dust or debris.

While the property is drying out, very high moisture levels are likely to occur. Therefore it is advisable that if the installation and building works are complete the unit is left running. If the building works are not complete please close the air valves or cover up the air valves to prevent condensation forming in the ductwork and the MRXBOX95 unit due to natural migration of warm air.

## 3.0 DIMENSIONS (mm)

Figure 11. Unit dimensions.

UNIT WEIGHT = 45Kg

if ancillary distribution box (DB-ECO2) is to be used refer to documentation supplied with DB-ECO2 as requirements will differ.

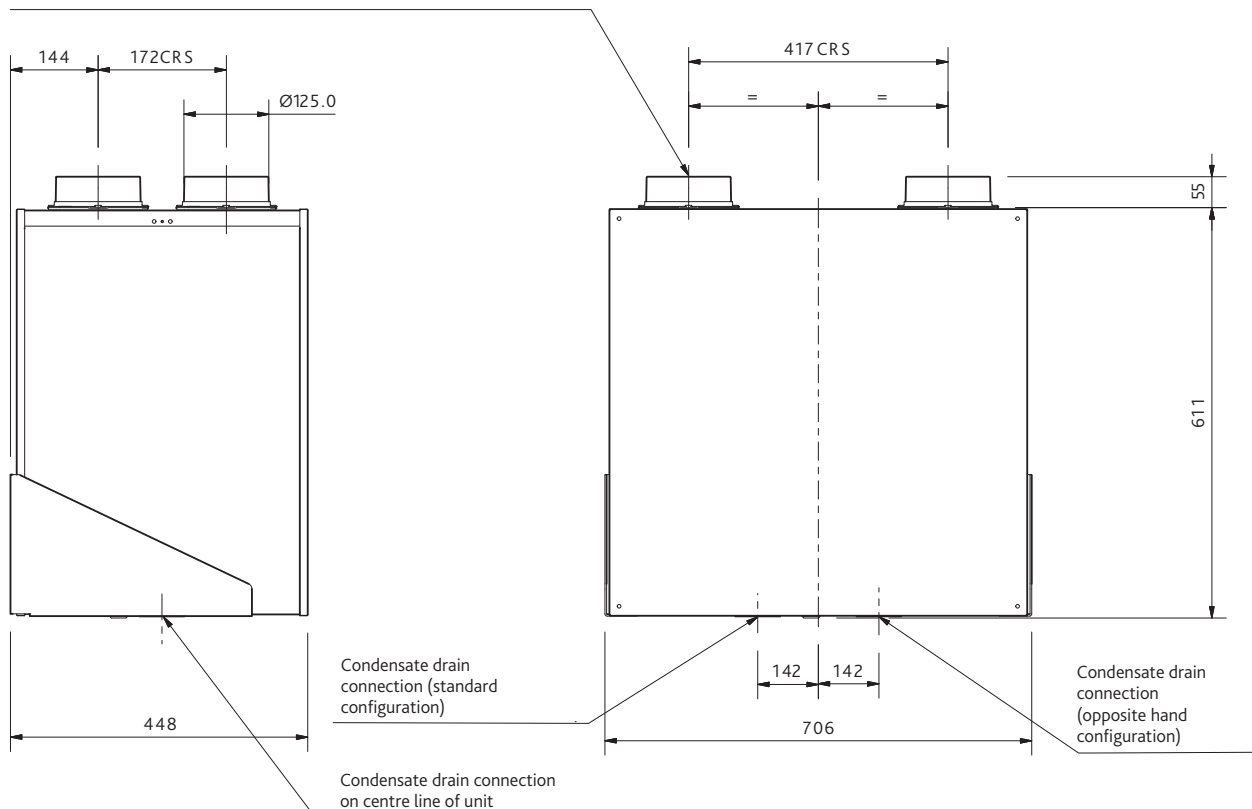

## 4.0 DUCTING ARRANGEMENTS - STANDARD CONFIGURATION

Figure 12. Typical ducted arrangement for a wall mounted unit using circular ducting.

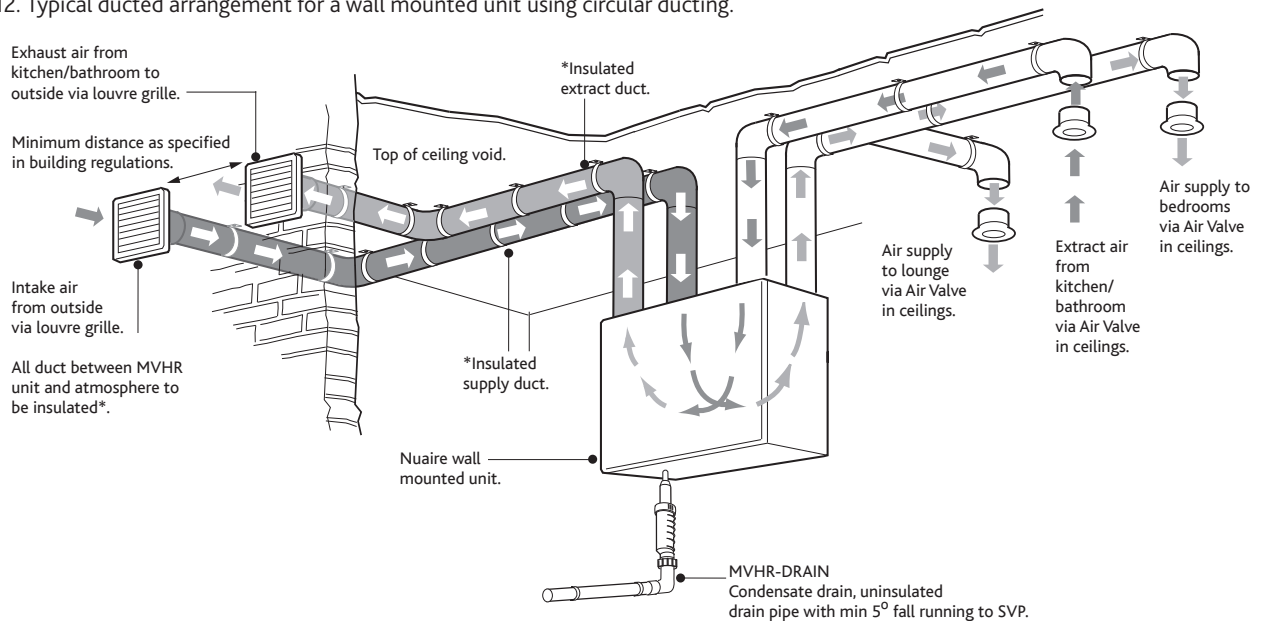
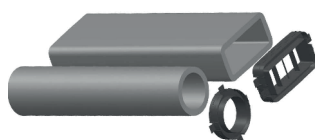
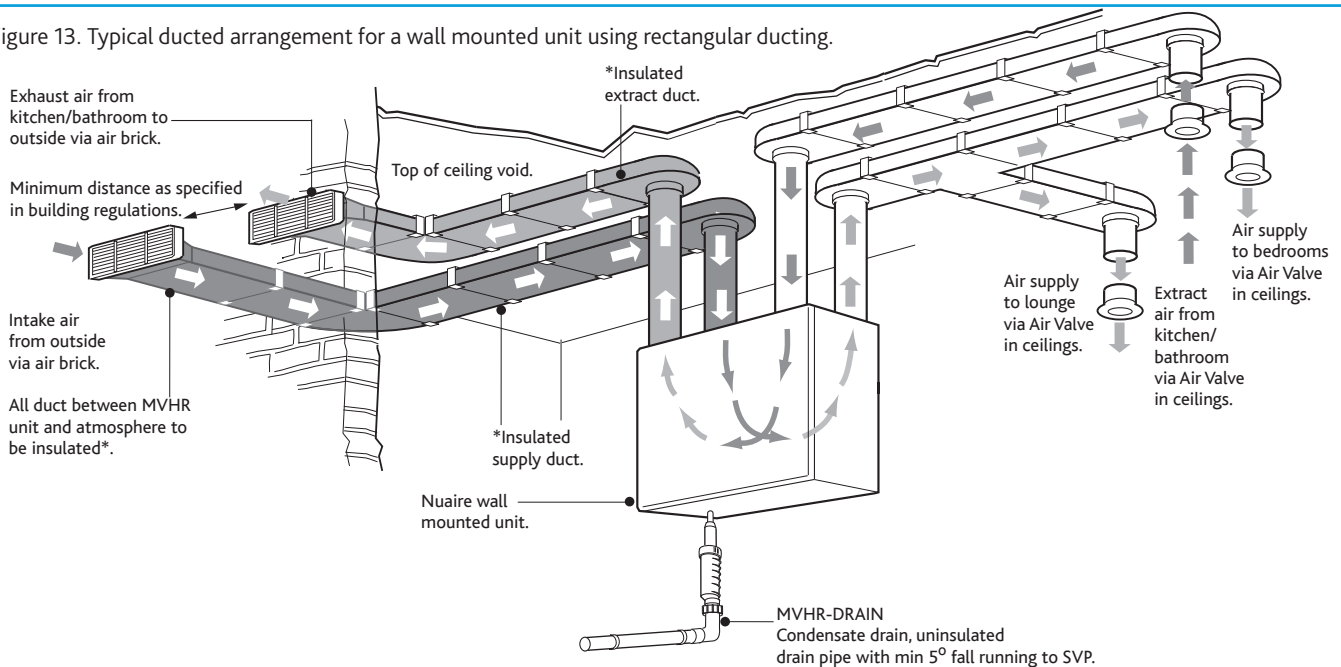

Figure 13. Typical ducted arrangement for a wall mounted unit using rectangular ducting.



ALSO FROM NUAIRE -

New **ductmaster** range of thermal ducting, an all-in-one insulated ducting system (see installation document 671780)

## 5.0 ELECTRICAL CONNECTION

Figure 14. PCB Details

### IMPORTANT

For good EMC engineering practice, any sensor cables or switched live cables should not be placed within 50mm of other cables or on the same metal cable tray as other cables.

Please note: the electrical connection of the unit must be carried out by a qualified electrician.

The unit is supplied with a flexible cord for connection to the mains supply.

#### Electrical details:-

**Voltage: 240V 1ph 50Hz**

**Consumption: 1.2 Amp**

**Fuse rating: 3 Amp**

**NOTE This unit must be earthed.**

The cable from the mains power supply should be connected to a fixed wiring installation, via a fused isolator, in accordance with current IEE wiring regulations.

Note: Wiring is for reference purposes only as the connections in fig. 14 are factory fitted. The unit is pre-wired with a 2 metre fly lead.

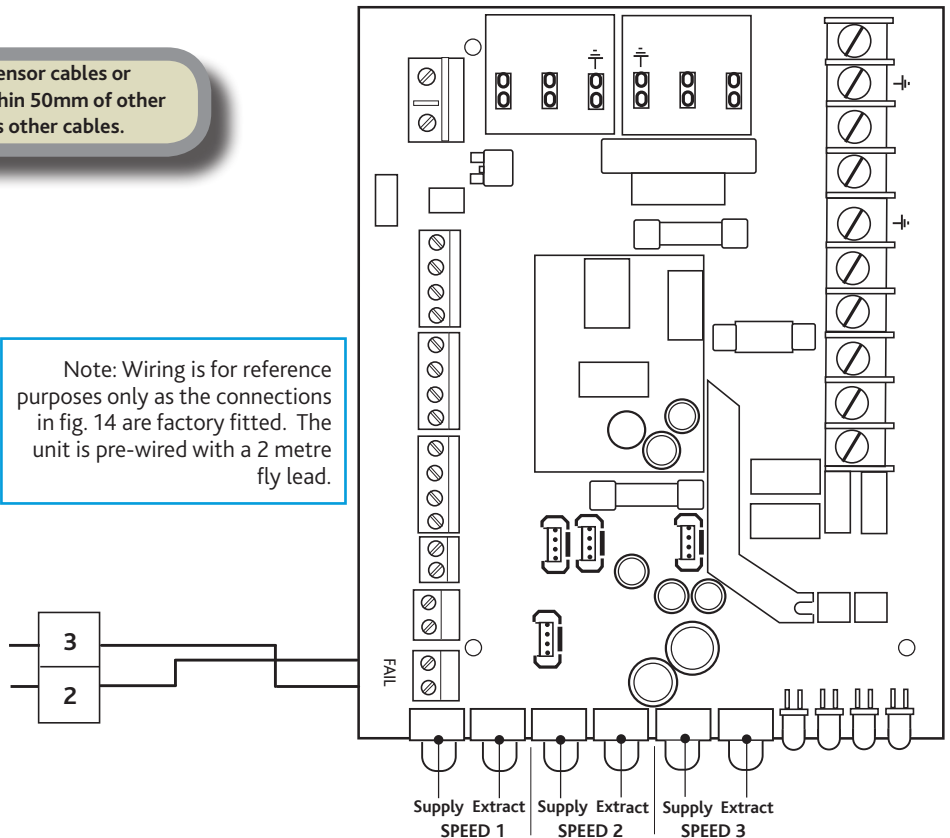

### Unit serving kitchen and bathroom

Figure 15.

Disconnection from the supply mains must be incorporated within the fixed wiring in accordance with the wiring regulations and shall have a minimum contact separation of 3mm.

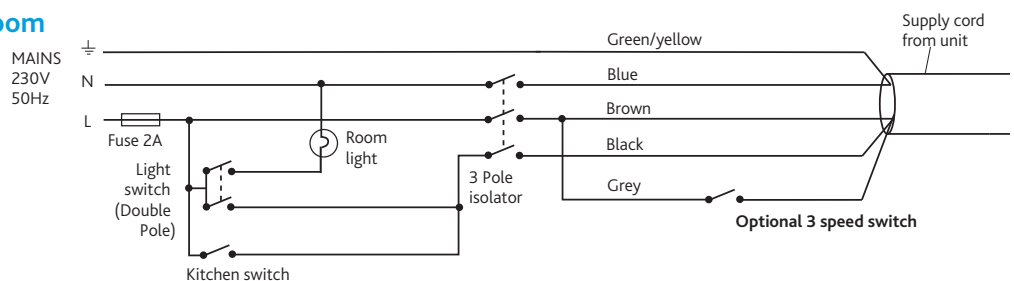

### Unit serving kitchen and two bathrooms

Figure 16.

Disconnection from the supply mains must be incorporated within the fixed wiring in accordance with the wiring regulations and shall have a minimum contact separation of 3mm.

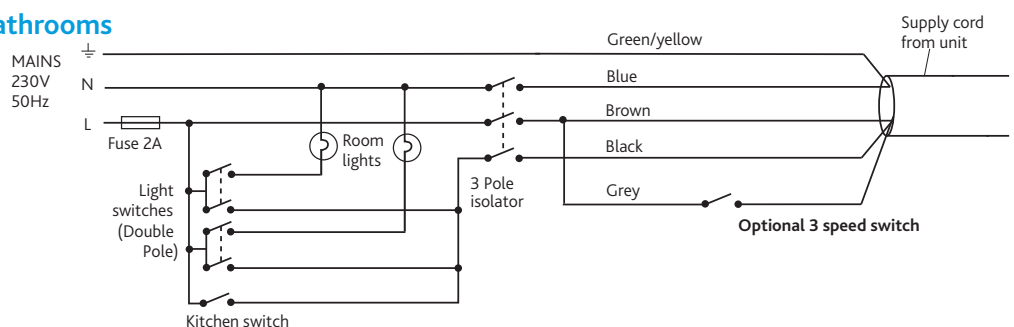

### Connection of summer/winter switch

Figure 17. Summer / Winter switch

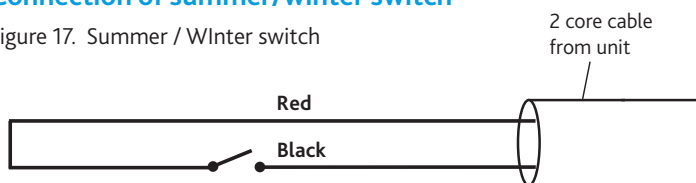

Volt free Summer / Winter Switch (supplied with unit)  
Polarity is inconsequential  
Warning! - Do not connect to mains!

**5.1 Optional Controls - For further information regarding optional controls, contact Nuair on 02920 858 400.**

## 6.0 COMMISSIONING

### IMPORTANT

The filters fitted inside the unit are protected with a plastic film. Prior to commissioning remove the covers (figs. 15 & 16), take off the film and replace.

1. For the required air flow rates please refer to the design specification for the property, follow 2.4, or refer to building regulations ADF 2010.
2. The unit is supplied with independent control for both normal and boost airflows (see fig. 18).
3. Correct commissioning is essential to ensure the ventilation air flow rates are met. It also ensures the unit is not over ventilating and causing excessive power consumption.
4. Commissioning should be carried out in accordance with building regulations document "Domestic ventilation compliance guide". [www.planningportal.gov.uk/building-regulations/approved-documents/partf/associated](http://www.planningportal.gov.uk/building-regulations/approved-documents/partf/associated)  
A calibrated moving vane anemometer and hood will be required to carry out commissioning.
5. Adjustment valves should be locked in place to prevent further adjustment.
6. Once commissioned the home owner / tenant should be informed that the unit should not be adjusted as it will have a detrimental effect on the indoor air quality and could result in condensation and mould growth. The clear panel covering the control has an adhesive panel which should be exposed and sealed post commissioning to prevent tampering.
7. Speed 1 is limited to never exceed speed 2, when commissioning speed 2 should always be set first.

Figure 18. Detail of unit control on front panel (standard configuration only).

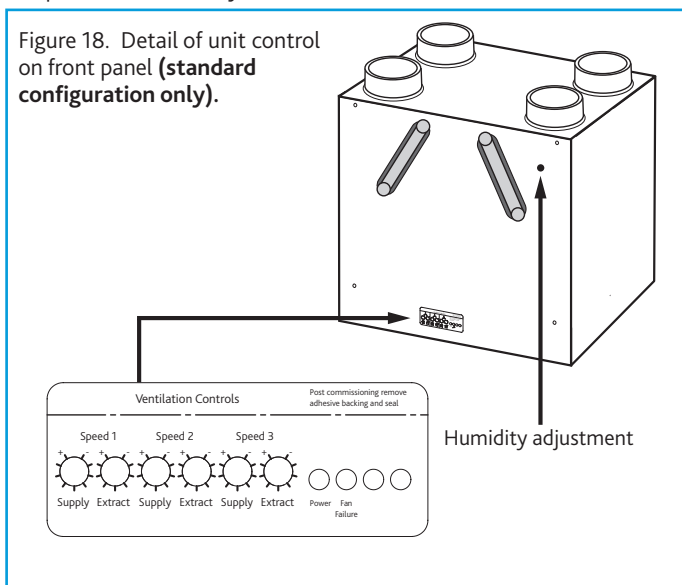

### 6.1 Humidity adjustment

This product contains an internal humidity sensor fitted into the air-flow extracting from the wet rooms. When the unit senses that the humidity exceeds the set point the unit will boost to that set by the commissioned boost speed. The set point can be found on the front of the unit (see fig. 18) and is at its least sensitive when turned fully clockwise. Note that the sensor is measuring humidity from all the wet rooms at the same time and should not be relied on to solely boost the unit. Additional switch should be used local to the wet rooms (see wiring diagrams).

## 7.0 STATUS INDICATION

The status of the unit is indicated by a series of LED's on the front cover. The variants are listed below.

Speed 1	●	○	○	○
Speed 2	●	○	☀	○
Speed 3	●	○	●	○
Supply Fan Fault	●	●	○	○
Extract Fan Fault	●	●	○	○
Frost Protection	●	○	●	●
Filter Change	●	○	☀	☀
HX Bypass (AB units only)	●	○	☀	☀

**Note:** The display on the unit control panel will not indicate when a higher speed setting has been triggered by an external source, such as an ES-PIR2 etc.

## 8.0 INTEGRAL AUTOMATIC HX BYPASS

Intake and extract temperatures are monitored at the point the airflows enter the unit, if the range falls within the set parameters the bypass damper is opened automatically to target an indoor comfort temperature all year round.

### 8.1 Summer / Winter Switch

When the switch position is set to Summer the integral automatic summer bypass is fully operational, in the alternative Winter position the HX bypass is disabled to ensure the unit is constantly in heat recovery mode.

### 8.2 Frost Protection

In the event of the intake air temperature at the unit dropping below the predetermined set point (-5°C as standard) the supply fan will reduce to minimum speed, once the temperature rises above the set point the fan will return to its commissioned speed.

Please note this mode will only activate after ten days of continuous run time. If commissioning of the unit is outside of this timeframe please notify the after sales department prior to site visit.

## 9.0 MAINTENANCE

### IMPORTANT

Isolation - Before commencing work make sure that the unit, switched live and Nuaire control are electrically isolated from the mains supply and switched live supply.

We recommend that the two filters are inspected after 6 months and replaced every 12 to 18 months. The filters can be removed from the unit by removing the two filter covers on the front panel of the unit. Take hold of the two circular tabs either end of the filter covers and pull out.

The filter can now be extracted by pulling the removal loop on the front edge of the filter. Once the filters have been inspected return or replace them as necessary. Inspect the heat exchanger every 5 years. Generally check for damage and security of components. Refit cover.

Figure 19. Removing the two filter covers on the front panel of the unit. The filters can be removed by pulling on the black tab on the visible end of the filters.

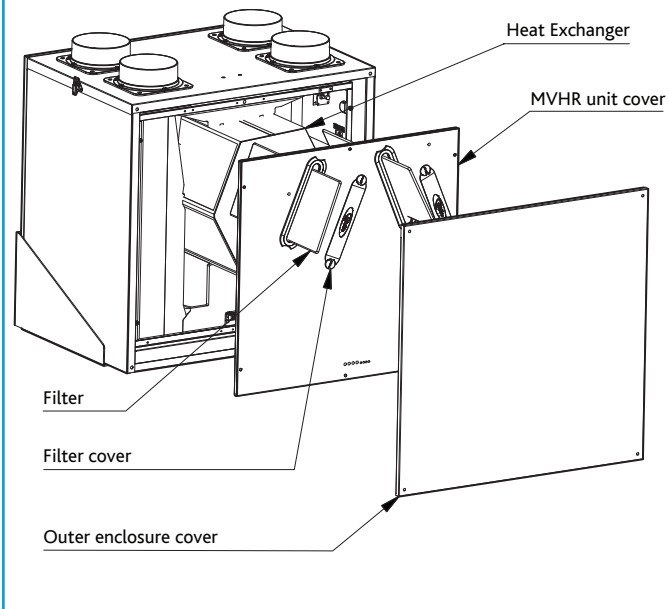

## 10.0 REPLACEMENT OF PARTS

Should any component need replacing, Nuair keep extensive stocks for quick delivery. Ensure that the unit is electrically isolated, before carrying out any work.

Note: The supply cable must be replaced by an electrically competent person.

When ordering spare parts, please quote the serial number of the unit and the ARC number of the purchase, if possible. (This information will be available on the fan label).

## 11.0 WARRANTY

The 5 year warranty starts from the day of delivery and includes parts and labour for the first year and parts only for the remaining 4 years.

This warranty is void if the equipment is modified without authorisation, is incorrectly applied, misused, disassembled, or not installed, commissioned and maintained in accordance with the details contained in this manual and general good practice.

The product warranty applies to the UK mainland and in accordance with Clause 14 of our Conditions of Sale. Customers purchasing from outside of the UK should contact Nuair International Sales office for further details.

## 12.0 AFTER SALES

For technical assistance or further product information, including spare parts and replacement components, please contact the After Sales Department.

**Telephone 02920 858 400**  
[aftersales@nuaire.co.uk](mailto:aftersales@nuaire.co.uk)