

Installation and Maintenance

1.0 SAFETY INFORMATION

- This appliance should not be used by children or persons with reduced physical, sensory or mental capabilities or lack of experience and knowledge, unless they have been given supervision or instruction concerning the safe use of the appliance by a person responsible for their safety. Children shall not play with the appliance. Cleaning and user maintenance shall not be carried out by children.

1.1 Symbols



REFER TO INSTRUCTION MANUAL

Read and understand the installation and maintenance manual before installing, operating or maintaining this product.

1.2 Important Information

This manual contains important information on the safe and appropriate assembly, transport, commissioning, operation, maintenance, disassembly and simple troubleshooting of the product.

While the product has been manufactured according to the accepted rules of current technology, there is still a danger of personal injury or damage to equipment if the following general safety instructions and the warnings contained in these instructions are not complied with.

- **Read these instructions completely and thoroughly before working with the product.**
- **Keep these instructions in a location where they are accessible to all users at all times.**
- **Always include the operating instructions when you pass the product on to third parties.**

1.3 Personal Protective Equipment

The following minimum Personal Protective Equipment (PPE) is recommended when interacting with Nuaire product:

- **Protective Steel Toed Shoes** - when handling heavy objects.
- **Full Finger Gloves (Marigold PU800 or equivalent)** - when handling sheet metal components.
- **Semi Fingerless Gloves (Marigold PU3000 3DO or equivalent)** - when conducting light work on the unit requiring tactile dexterity.
- **Safety Glasses** - when conducting any cleaning/cutting operation or exchanging filters.
- **Reusable Half Mask Respirators** - when replacing filters which have been in contact with normal room or environmental air.

Nuaire would always recommend a site specific risk assessment by a competent person to determine if any additional PPE is required.

2.0 INTRODUCTION

The MRXBOX-AV2 is designed to provide a method of installation that isolates the unit from the structure of the property; the product accommodates both wall and floor mounting.

3.0 MECHANICAL INSTALLATION

Installation must be carried out by competent personnel in accordance with the appropriate authority and conforming to all statutory governing regulations.

The fan must be installed indoors on a suitable wall away from direct sources of frost, heat and water spray or moisture generation. For a vibration free result the unit must be mounted on a solid wall.

The hanging brackets of the MVHR unit and any ancillary silencer are redundant when fitting the MRXBOX-AV2 and should not be used.

For specific installation requirements of the MVHR unit to be installed please refer to the installation and maintenance guide supplied with the unit, the document covers additional items including access requirements, airflow configurations, condensate drainage, electrical connection and maintenance requirements that may influence the location the MRXBOX-AV2 is to be installed.

Care must be taken to ensure the unit is installed true in all the dimensions, failure to do so may result in overflow from the internal condensation drip tray. To allow the anti-vibration mounts to operate effectively no part of the MVHR unit should be in direct contact with the building structure including any boxing in of the duct connections, the only component of the assembly that should be in contact is the mounting bracket.

3.1 Installation Procedure

All items referenced below including relevant fixings are supplied with the MRXBOX-AV2, the exception being the fixings to secure the wall brackets and the frame/plinth for floor mounting as these are specific for the individual installation.

3.2 Support Tray (Floor / Wall Mounting)

Fix 4x rubber stand offs to the top face of the support tray using four M4 x 20 screws. Fix 4x Anti-vibration mounts to the underside of the support tray using two M4x 16 screws and washers per anti-vibration mount.

Next take the MVHR unit to be mounted and remove the two rubber stand offs found on the rear panel and place the unit on the support tray, the two fixing points now free can be used to secure the unit to the tray using two M5 screws and large washers.

Continue to the appropriate section for the next steps of the installation depending on if the unit is to be floor or wall mounted, there is also additional information to assist installation in a loft space.

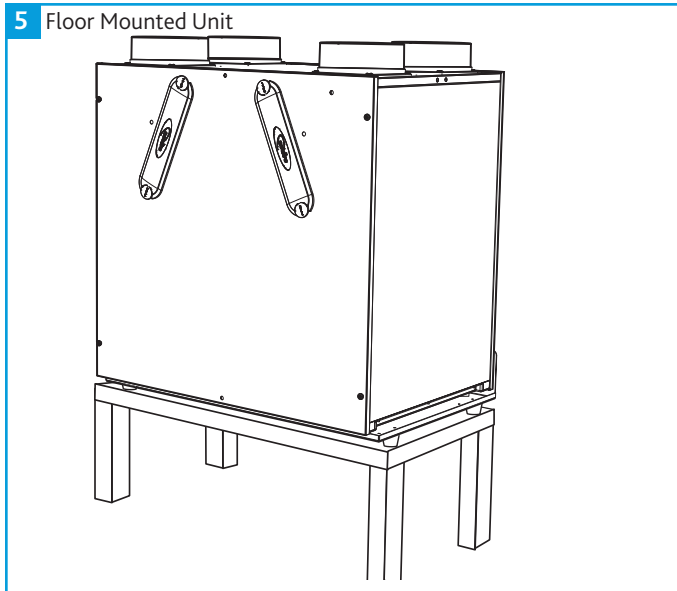
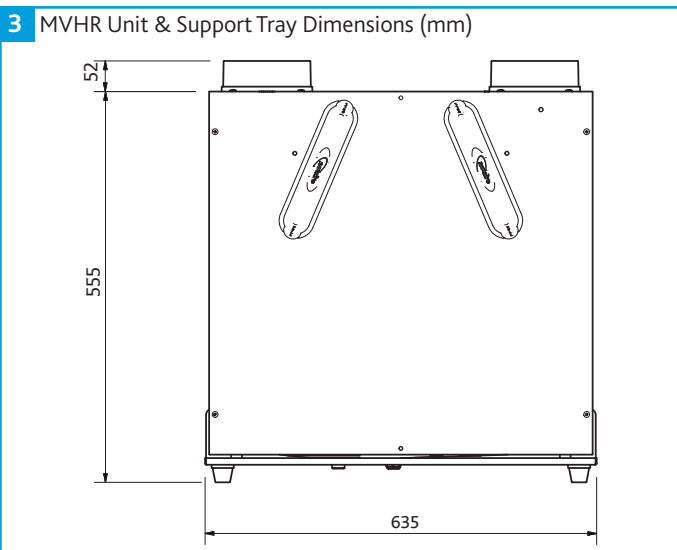
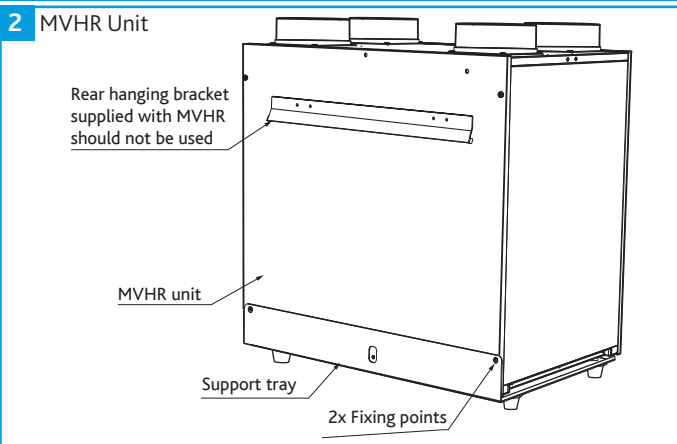
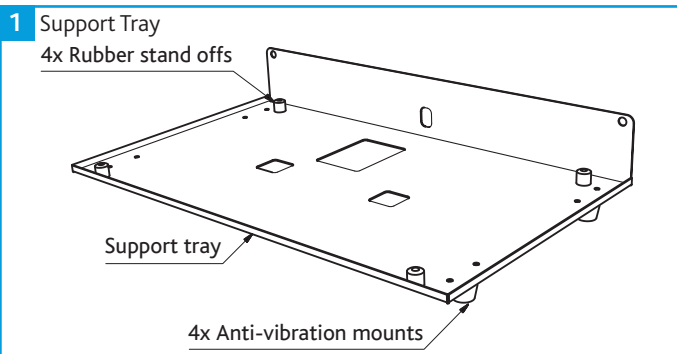

3.4 Wall Mounting

The unit is designed for mounting on a solid wall, a gypsum block or stud/plasterboard wall will not suffice. If fixing to a stud wall a piece of MDF at least 25mm thick should be solidly fixed behind the board, the MDF panel should ideally run from floor to ceiling but must be a minimum of 2m. The MDF panel should also extend width wise over a minimum of three studs with centres no more than 400mm, additional vertical supports may be required.

Fit the two angle brackets (Figure 6) to suitable mounting structure (fixings not supplied) and secure cross brace using M5 screws.

The unit and support tray sub-assembly (Figure 7) can then be placed on the wall brackets and secured in place using the four M8 bolts for each of the threaded AV mounts.

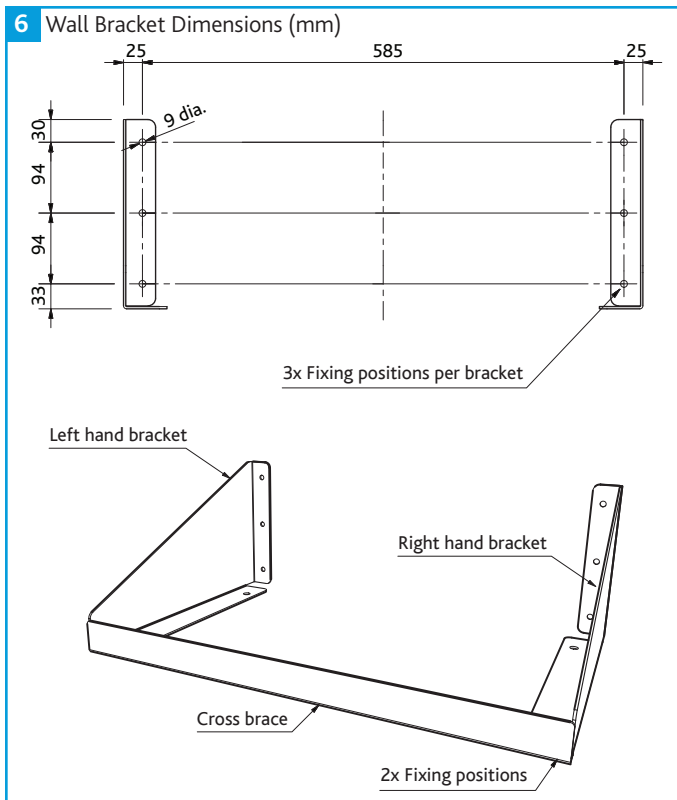

3.3 Floor Mounting

The assembly is now completed and can be secured to the desired frame/plinth (not provided) using the four M8 bolts or each of the threaded AV mounts (Figures 4 and 5).

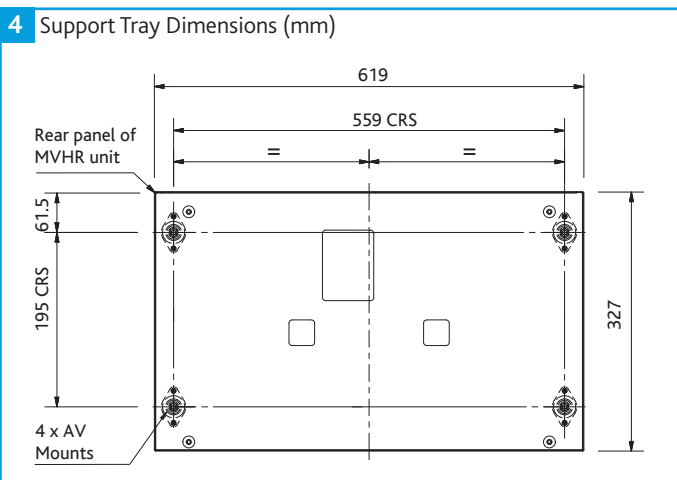

7 Wall Mounted Unit

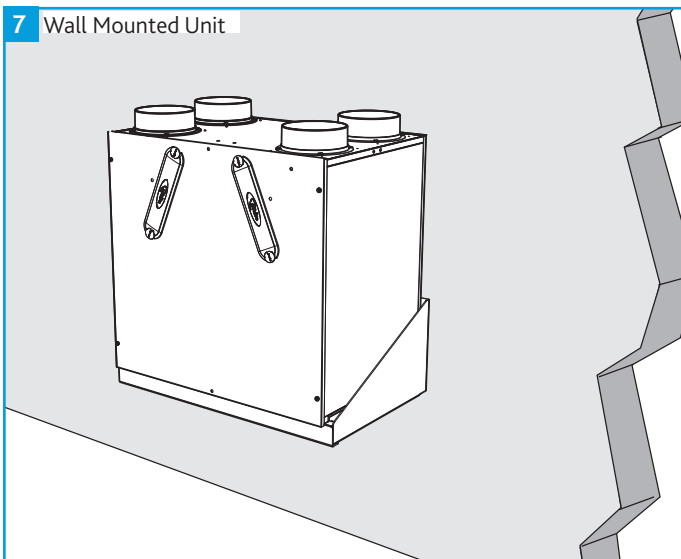

3.5 Loft Mounting

If mounting the unit in a loft space either the floor mounting method can be utilised or a false wall will need to be created to allow installation as per the wall mounting method. The false wall should be a MDF panel with a minimum thickness 25mm that is vertically fixed across the roof trusses to form a solid structure, additional vertical supports may also be necessary (Figure 8).

8 Loft Mounted Unit

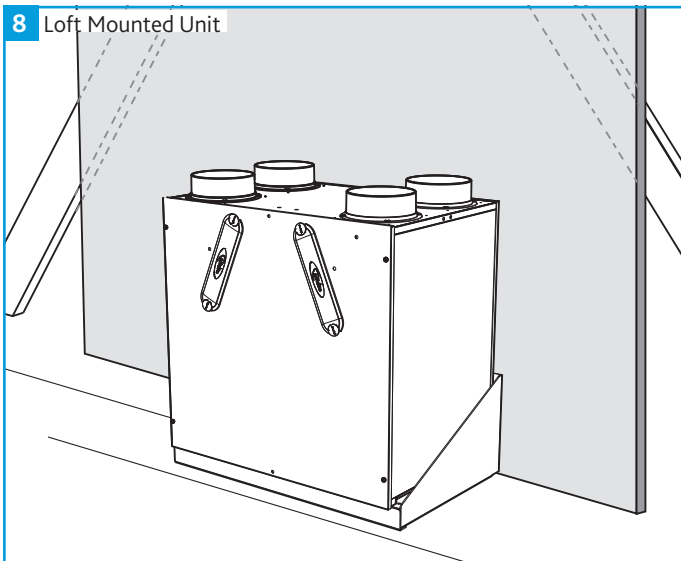

5.0 END-OF-LIFE AND RECYCLING

Where possible Nuaire use components which can be largely recycled when the product reaches its end-of-life:

- Fans, motors, controls, actuators, cabling and other electrical components can be segregated into WEEE recycling streams.
- Sheet metal parts, aluminium extrusion, heating/cooling coils and other metallic items can be segregated and fully recycled.
- EPP, plastic ducting, nylon corner pieces, plastic heat exchangers, packaging material and other plastic components can be segregated into mixed plastic and widely recycled.
- Cardboard packaging, wood, used filters and other paper components can be largely recycled or fully processed in energy from waste centres.
- Remaining Items can be further segregated and processed in accordance with the zero waste hierarchy. Please call After Sales Support for further information on items not listed above.

Ensure that Nuaire product is made safe from any electrical / water / refrigerant supplies before dismantling commences. This work should only be undertaken by a qualified person in accordance with local authority regulations and guidelines, taking into account all site based risks.

6.0 AFTER SALES AND REPLACEMENT PARTS

For technical assistance or further product information, including spare parts and replacement components, please contact the After Sales Department.

If ordering spares please quote the serial number of the unit together with the part number, if the part number is not known please give a full description of the part required. The serial number will be found on the identification plate attached to the unit casing.

Telephone 02920 858 400
aftersales@nuaire.co.uk

Technical or commercial considerations may, from time to time, make it necessary to alter the design, performance and dimensions of equipment and the right is reserved to make such changes without prior notice.

4.0 WARRANTY

The warranty starts from the day of delivery and includes parts and labour for the first year. The remaining period covers replacement parts only.

This warranty is void if the equipment is modified without authorisation, is incorrectly applied, misused, disassembled, or not installed, commissioned and maintained in accordance with the details contained in this manual and general good practice.

The product warranty applies to the UK mainland and in accordance with Clause 14 of our Conditions of Sale. Customers purchasing from outside of the UK should contact Nuaire International Sales office for further details.

Only genuine Nuaire parts and filters may be used to maintain the unit. Failure to maintain the unit as recommended will invalidate the warranty.

