

# XB-EFA-8L-GT & XB-EFA-8R-GT

## Supply & Extract Ventilation Unit with Heat Recovery

### Installation, Operating and Maintenance Instructions

The information contained in this document provides details of installation, operation and maintenance for installers and users of the XB-EFA-8 Supply and Extract Ventilation Unit with Heat Recovery.

This supply and extract air handling unit comprises a combination of high efficiency centrifugal fans with EC motors, controls, a counterflow design enthalpy type plate heat exchanger, and supply and extract filters.

The unit casing includes highly absorbent acoustic treatment.

General information regarding performance and specifications for the equipment may be obtained from the project specific documentation.

#### Code description:

Left Hand unit: XB-EFA-8L-GT

Right Hand unit: XB-EFA-8R-GT

## 1.0 Unit Access

**Note - This product is available in functionally identical Left and Right hand variants.**

The unit Supply and Extract connections are positioned at one end of the unit (room-side connections).

The corresponding Intake and Discharge connections are positioned at the other end of the unit.

The unit must be installed with at least 600mm clearance from a wall / barrier on the access side (as required by ADF 2010).

With this clearance, access panels may be removed allowing unit filters to be changed, and the fans and heat exchanger may be inspected and cleaned as necessary.

#### IMPORTANT

**Safety first!** –before commencing any work ensure:

- That all appropriate risk assessments have been carried out, and the required safety measures have been taken
- That you understand the work required
- That you are trained and competent to carry it out

## 2.0 Delivery of equipment

### 2.1 Receipt of equipment

All equipment is inspected prior to despatch and leaves the factory in good condition.

Upon receipt of the equipment an inspection should be made and any damage indicated on the delivery note.

Particulars of damage and/or incomplete delivery should be endorsed by the driver delivering the goods before offloading by the purchaser.

No responsibility will be accepted for damage sustained during the offloading from the vehicle or on the site thereafter.

All claims for damage and/or incomplete delivery must be reported to Nuair within two days of receipt of the equipment.

### 2.2 Offloading and handling from the delivery vehicle

The weight of the unit modules and palletised items is displayed on the unit rating plate or on the packaging. Some products have an uneven weight distribution, and this will be indicated by labelling where appropriate. Ensure that lifting and handling equipment is adequately rated.

Offloading and positioning of the equipment is the responsibility of the purchaser.

Spreaders should be used when lifting with slings to avoid damage to the unit casing. Care must be taken to ensure that slings are correctly positioned to avoid crushing and twisting of the unit casing.

Figure 1: Lifting.

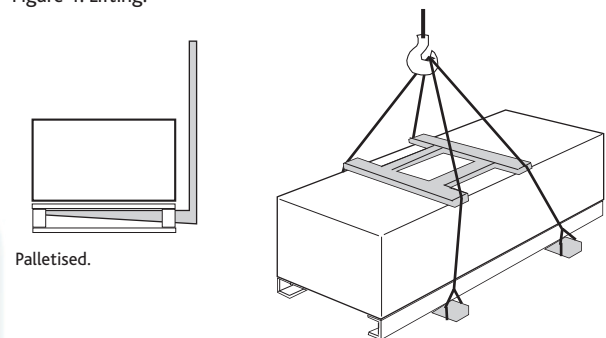

Slings via spreaders fitted to unit with base frame.

### 2.3 Storage

The equipment must be stored in a dry, internal location.

Ductwork connection apertures shall be sealed against the ingress of dust, water and vermin.

If the storage period is to exceed two months, contact Nuair for guidance on the appropriate "mothballing" procedures.

**Do not stack units, modules or components.**

### 3.0 Erection and Assembly

Units must be installed in accordance with good industry practice.

These units may only be mounted horizontally and must be fully levelled in the horizontal plane.

The units are heavy, and should be mounted using the fixing brackets supplied or other suitable methods of support.

The supporting structure must be assessed for structural suitability.

Electrical connections to the unit shall be made in accordance with the appropriate product (see below); and installation wiring diagrams, and shall use appropriately sized and rated cables.

Only the prepared apertures in the unit casing may be used for cable entry. Do not drill or cut the unit casing for this purpose. Cable access points are provided at the control enclosure.

NB to avoid conflict with the unit access panels, it is recommended that electrical and plumbing service connections to the unit are run at 90 degrees to the main air flow axis.

Control circuit connections must be segregated (i.e. routed separately) from power connections.

The unit rating label shows the maximum electrical load of the equipment. Connections to the unit may include single phase supply connections, and control circuits.

Control circuit connections must be segregated (i.e. routed separately) from power connections.

The equipment must be earthed and earth-bonded. Means of local isolation for maintenance purposes are generally required (by others).

Ensure that all mains connections are isolated.

### 4.0 Commissioning & Setting to work

#### IMPORTANT

Isolation - Before commencing work make sure that the unit and Nuaire control are electrically isolated from the mains supply.

#### 4.1 Filters

Remove filter access panels (observe and note airflow direction labels), inspect filters for contamination with construction debris, replace as necessary. Replace access panels.

Filter pressure drops will depend on actual flow rate and condition. If required, observe and record filter pressure drops after performance commissioning. Typically, filter "dirty" condition occurs when the initial filter "clean" readings have been increased by 25Pa.

#### 4.2 Fan Sections

Access to the fan section is via lift off panels.

Wiring to the unit terminal box should be mechanically protected and in made in accordance with the details on the motor name plate.

With the unit electrically isolated, gently rotate the fan impellers manually, checking that they spin freely.

**Check all fixings are secure.**

Units must not be operated without all access panels in place – damage to equipment or injury to personnel may result.

Units must not be operated unless control interlocks are in place – damage to equipment may result. Test run motor for condition and correct rotation. Check that the correct current overloads are fitted and that the current being drawn does not exceed the motor name-plate value.

Excessive current normally indicates that the ductwork system resistance is different to design.

### 5.0 Unit Wiring

The electrical wiring must be carried out by competent persons, in accordance with good industry practice and should conform to all governing and statutory bodies i.e. IEE, CIBSE, COHSE etc.

Connection diagrams are provided on page 4.

## 6.0 Control Specification

The HRU is supplied with a CYLON CBT12 based control.

### Software

(By others).

### Tacho Signal Converter (Fan Run Relay)

A PCB is fitted which provides a volt free relay output so show the fan running state. The relay is energized while all fans are running and de-energized if any fans stop.

Please note that the PCB requires at least one fan to start before the software routine runs.

### Temperature Sensors (Internal)

The unit is fitted with 3 x 10K3A1 thermistors for extract, supply and fresh air temperature.

### Fan Output

A 0-10v signal is required to run the supply and extract fans. The minimum starting voltage is 2 V.

### Belimo Actuator

The relay is used to power the 24 V AC face damper actuator.

### Supply Voltage

AC 207 – 253 V AC AC line Frequency

Hz 47 – 53Hz Supply Current

Total unit load 3A

### Operating Environment

-10 to 40°C

### Safety

- Installation must be by qualified personnel in accordance with local applicable standards.
- This equipment must be earthed.
- Access is limited to service personnel only. Live parts are accessible when cover is removed.
- Residual risk of contact with fan. Maintenance personnel should take due care and attention.
- EC Fans use Capacitors to store mains voltage. Contact with the mains wiring must be avoided for 5 minutes following supply disconnection.

7.0 Unit Wiring Information

Figure 2:

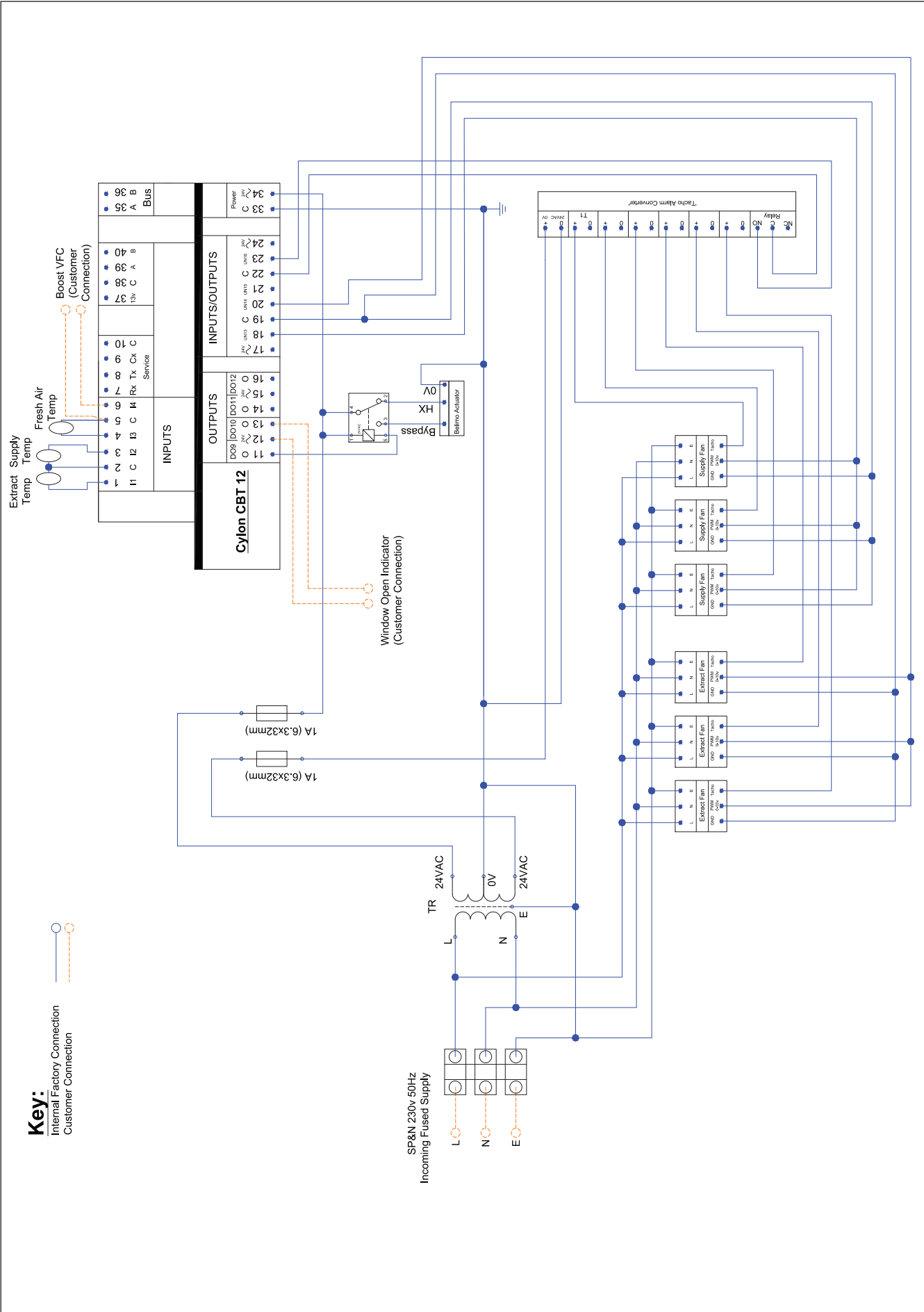

### 8.0 Unit Drawings

Figure 3: XB-EFA-8L-GT unit.

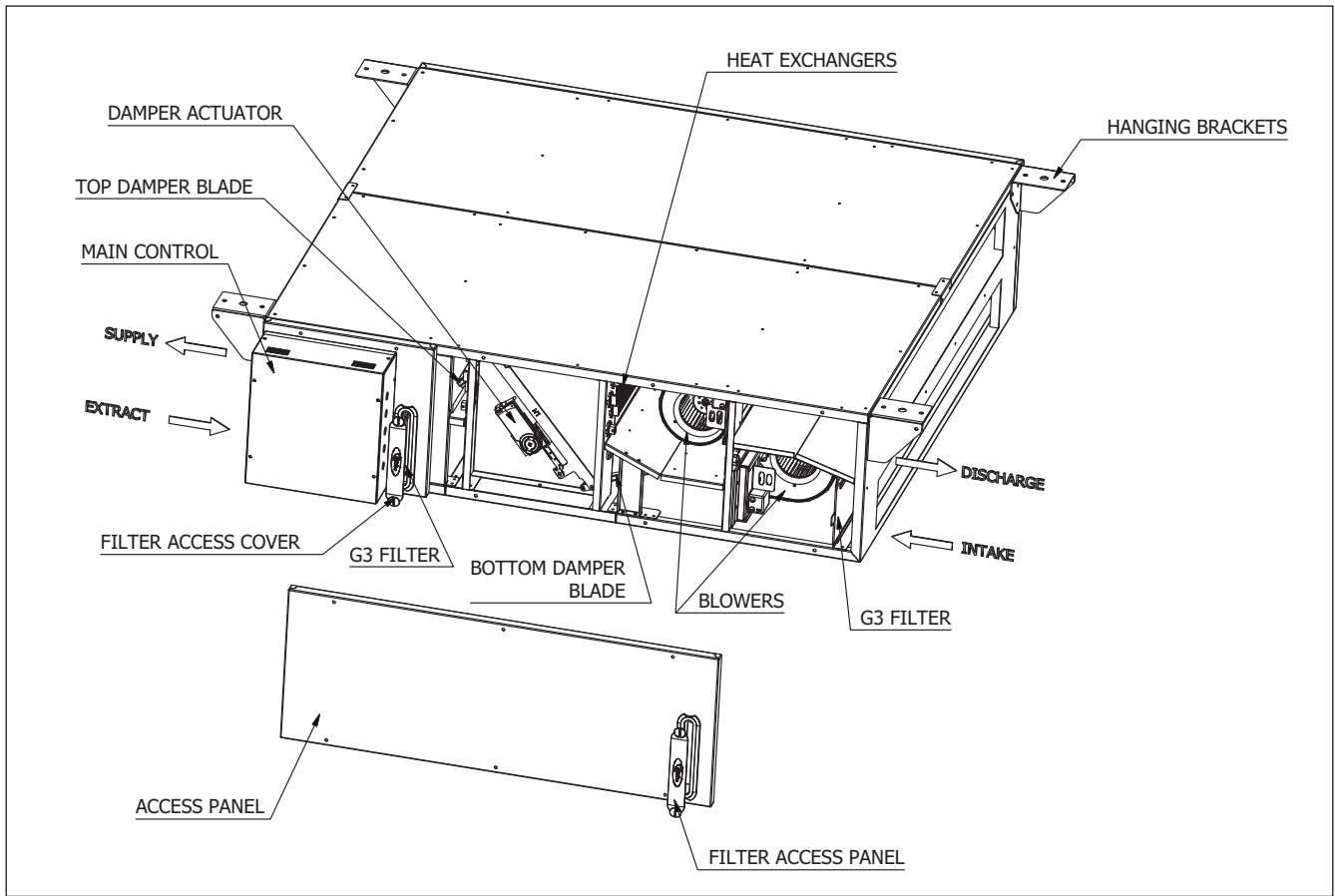
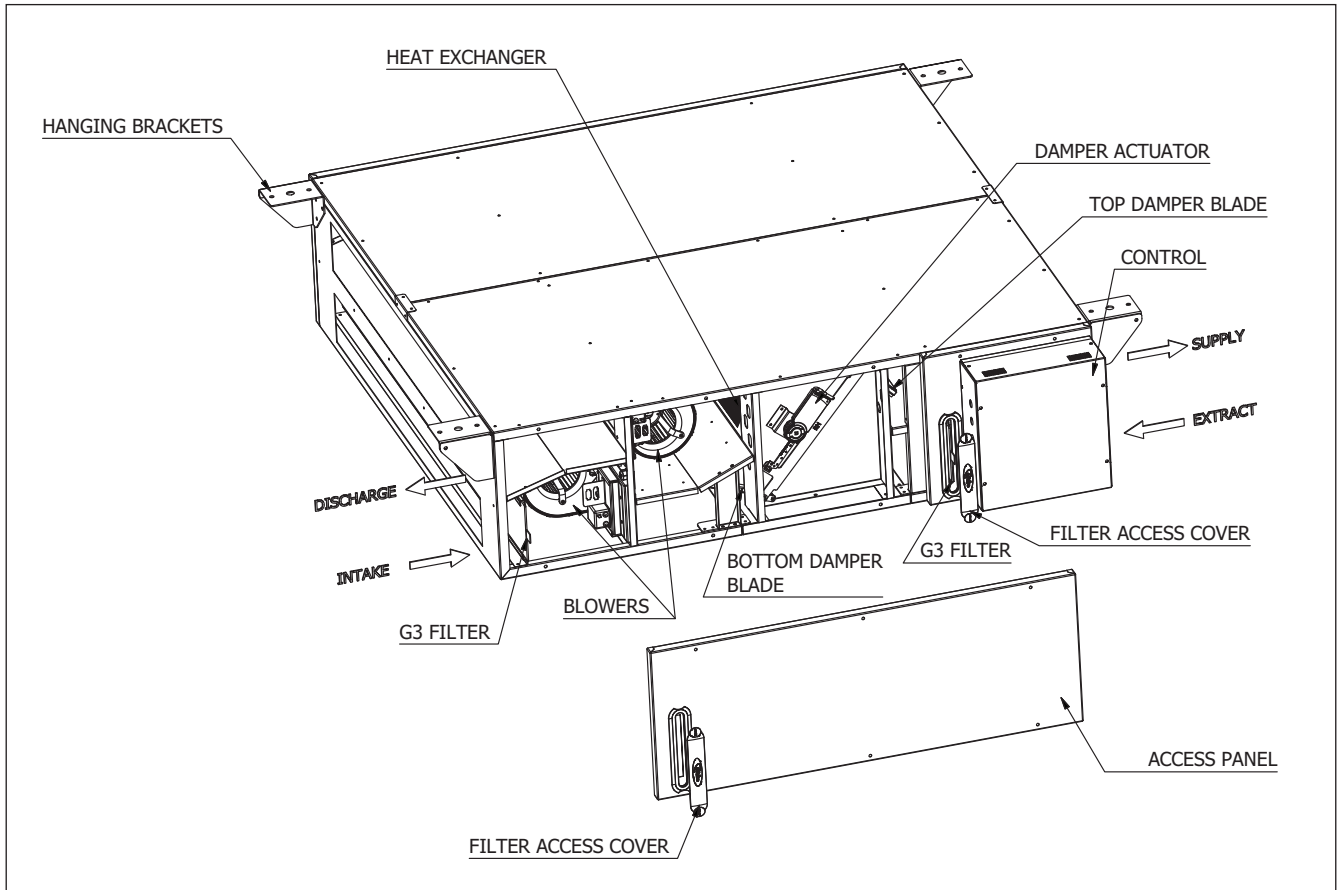

Figure 4: XB-EFA-8R-GT unit.



### 9.0 Unit Dimensions

Figure 5: XB-EFA-8L-GT Left handed unit.

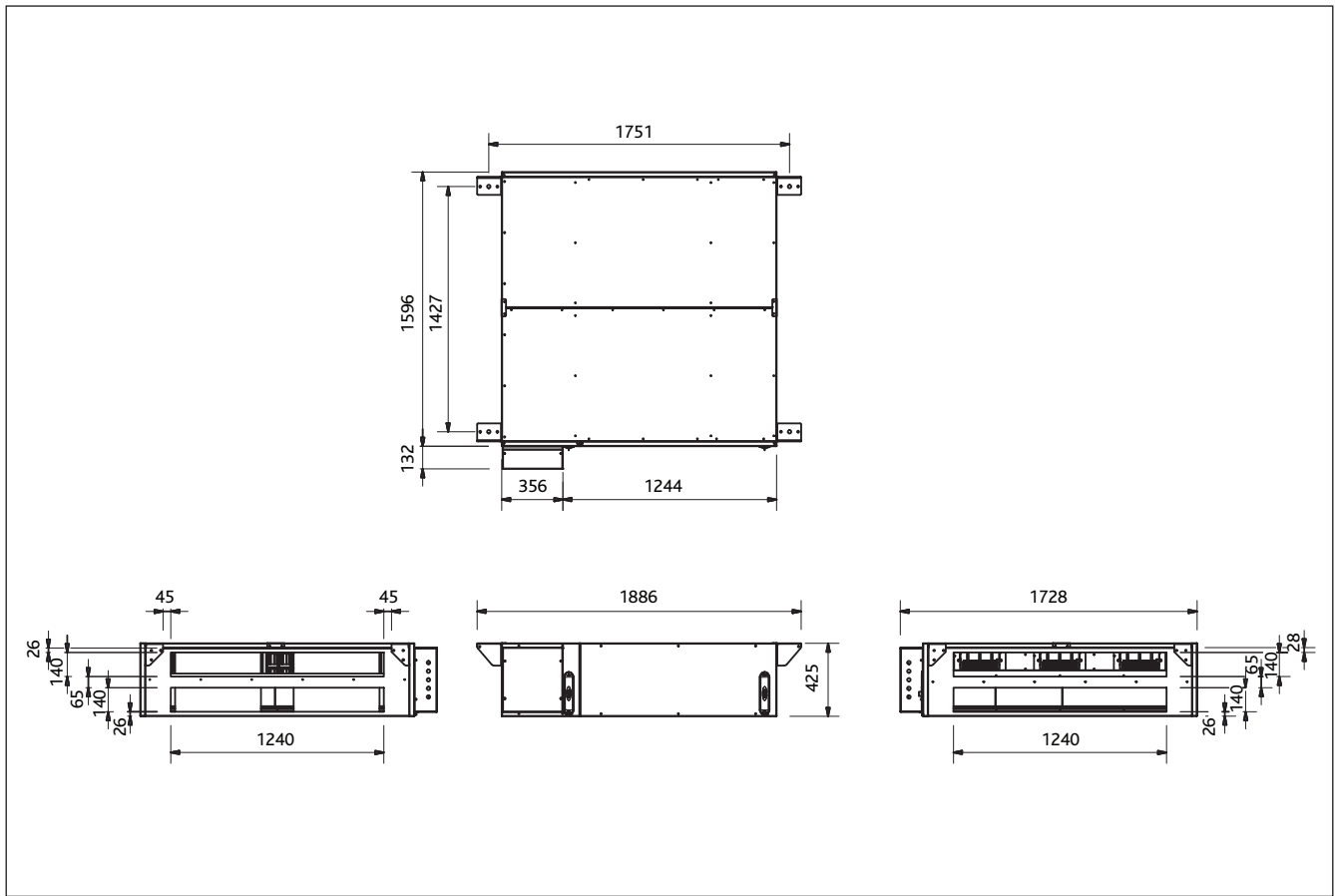
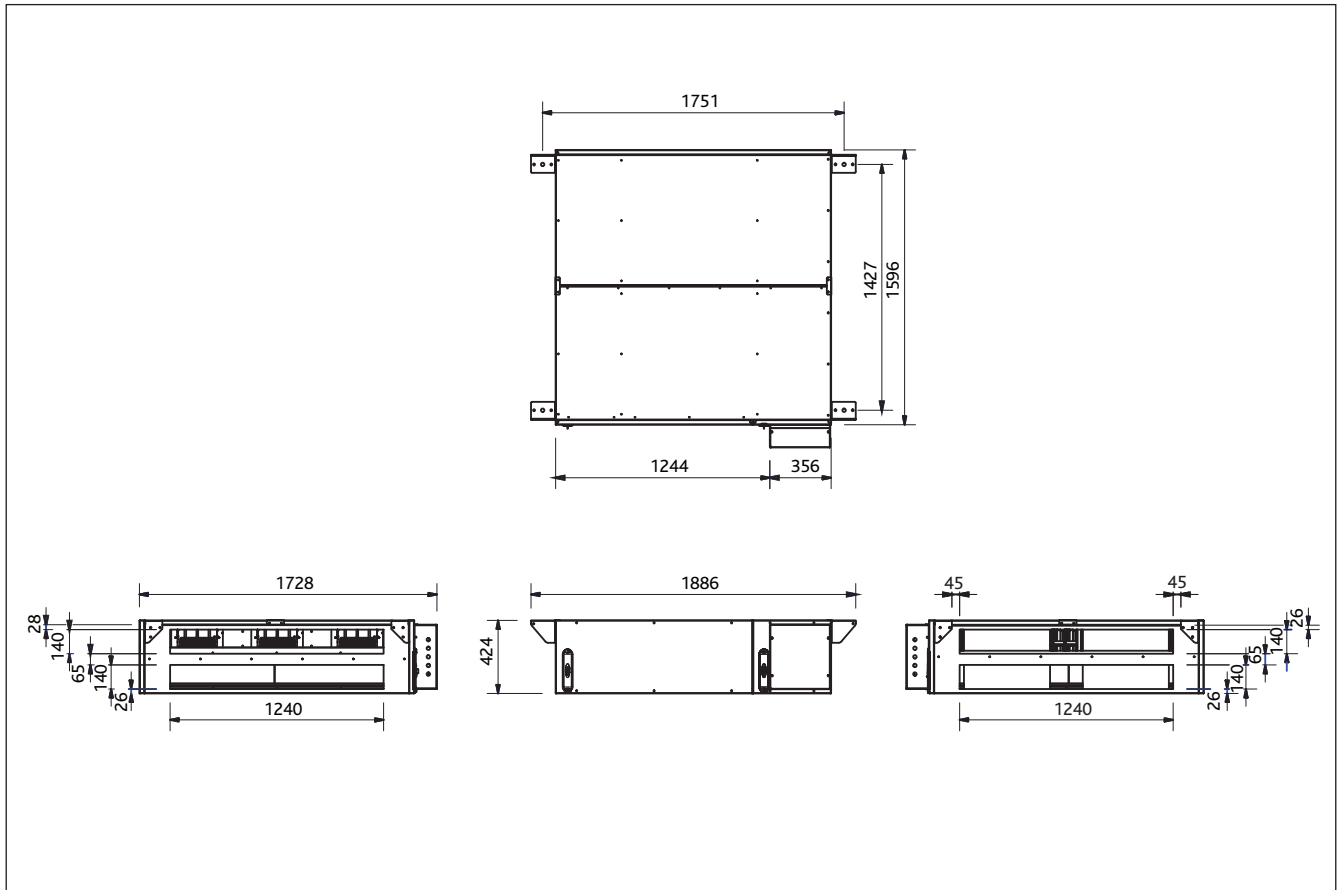

Figure 6: XB-EFA-8R-GT Right handed unit.



## 10.0 Maintenance

It is recommended that PPE is always used during the maintenance of Air Handling Equipment – gloves, eye shields and respiratory mask.

### IMPORTANT

**Isolation - Before commencing work make sure that the unit and Nuair control are electrically isolated from the mains supply.**

The appropriate maintenance interval will depend on the operating environment. It is recommended that an initial inspection be carried out after 3 months of normal operation, and the ongoing maintenance programme determined based on the unit's condition.

As noted previously, contamination occurring if the unit is operated during the construction phase, may be considerably greater than in normal operation.

### 10.1 Filters (2 x G3 Fitted as standard)

Disposable filters should be changed when an appropriate pressure drop is achieved. The filters may also be cleaned by vacuuming.

### 10.2 Counter-flow Plate Heat Exchanger

The heat exchanger block is normally protected from dust and contamination by upstream pre-filters. It is possible to clean the unit with compressed air in the case of dust deposits or by spraying with clean water. Do not use cleaning water at temperatures over 30 deg C. It is essential that the heat exchanger is air dried (without the application of heat) before being refitted to the unit.

Note that the heat exchanger is constructed from an advanced polymer that allows moisture transfer. On no account replace the heat exchanger with a physically similar type without this facility, as condensate leakage will occur.

### 10.3 Fans and Motors

Fan bearings should be manually checked at regular intervals for condition. Standard fan bearings are supplied as 'sealed for life' and have an anticipated life of 40,000 hours.

Motors have an enclosed bearing housing and are pre-greased for life.

**Check all fixings are secure.**

## 10.4 General

Inspect all internal and external surfaces to check for corrosion. Thoroughly clean affected areas with a wire brush, apply a coat of zinc rich primer or similar, and re-touch with suitable finishing paint.

Ensure tightness of all nuts, bolts, and fixings.

**Check all components for general condition.**

## 11.0 Warranty

Project specific warranty arrangements apply to this product – refer to project documentation.

This warranty is void if the equipment is modified without authorisation, is incorrectly applied, misused or not installed, commissioned and maintained in accordance with the details contained in this manual and general good practice.

**The product warranty applies to the UK mainland and in accordance with Clause 14 of our Conditions of Sale.**

**Customers purchasing from outside of the UK should contact Nuair International Sales office for further details.**

## 12.0 After Sales

For technical assistance or further product information, including spare parts and replacement components, please contact the After Sales Department.

**Telephone 029 2085 8400  
Fax 029 2085 8444**

## DECLARATION OF INCORPORATION AND INFORMATION FOR SAFE INSTALLATION, OPERATION AND MAINTENANCE

We declare that the machinery named below is intended to be assembled with other components to constitute a system of machinery. All parts except for moving parts requiring the correct installation of safety guards comply with the essential requirements of the Machinery Directive. The machinery shall not be put into service until the system has been declared to be in conformity with the provisions of the EC Machinery Directive.

Designation of machinery: XB-EFA-8L-GT & XB-EFA-8R-GT  
 Machinery Types: Supply & Extract fans with Heat Recovery  
 Relevant EC Council Directives: 2006/42/EC (Machinery Directive)  
 Applied Harmonised Standards: BS EN ISO 12100-1, BS EN ISO 13857, EN60204-1, BS EN ISO 9001  
 Applied National Standards: BS548 Parts 1, 2.2 and 5  
 Note: All standards used were current and valid at the date of signature.

Signature of manufacture representatives:

Name:	Position:	Date:
1) C. Biggs	Technical Director	26.04.14
2) A. Jones	Manufacturing Director	26.04.14



## INFORMATION FOR SAFE INSTALLATION, OPERATION AND MAINTENANCE OF NUAIRE VENTILATION EQUIPMENT

To comply with EC Council Directives 2006/42/EC' Machinery Directive and 2004/108/EC (EMC).

To be read in conjunction with the relevant Product Documentation (see 2.1)

### 1.0 GENERAL

1.1 The equipment referred to in this Declaration of Incorporation is supplied by Nuairé to be assembled into a ventilation system which may or may not include additional components.

The entire system must be considered for safety purposes and it is the responsibility of the installer to ensure that all of the equipment is installed in compliance with the manufacturers recommendations and with due regard to current legislation and codes of practice.

### 2.0 INFORMATION SUPPLIED WITH THE EQUIPMENT

2.1 Each item of equipment is supplied with a set of documentation which provides the information required for the safe installation and maintenance of the equipment. This may be in the form of a Data sheet and/or Installation and Maintenance instruction.

2.2 Each unit has a rating plate attached to its outer casing. The rating plate provides essential data relating to the equipment such as serial number, unit code and electrical data. Any further data that may be required will be found in the documentation. If any item is unclear or more information is required, contact Nuairé.

2.3 Where warning labels or notices are attached to the unit the instructions given must be adhered to.

### 3.0 TRANSPORTATION, HANDLING AND STORAGE

3.1 Care must be taken at all times to prevent damage to the equipment. Note that shock to the unit may result in the balance of the impeller being affected.

3.2 When handling the equipment, care should be taken with corners and edges and that the weight distribution within the unit is considered. Lifting gear such as slings or ropes must be arranged so as not to bear on the casing.

3.3 Equipment stored on site prior to installation should be protected from the weather and steps taken to prevent ingress of contaminants.

### 4.0 OPERATIONAL LIMITS

4.1 It is important that the specified operational limits for the equipment are adhered to e.g. operational air temperature, air borne contaminants and unit orientation.

4.2 Where installation accessories are supplied with the specified equipment eg. wall mounting brackets. They are to be used to support the equipment only. Other system components must have separate provision for support.

4.3 Flanges and connection spigots are provided for the purpose of joining to duct work systems. They must not be used to support the ductwork.

4.4 **Local Environment - Humidity.** Ambient humidity (the humidity at the unit's installed location) shall be within the range: 10 to 95% (for controls, non-condensing). Air humidity (the humidity of the air passing through the unit) shall be within the range: 10 to 95% (for controls, non-condensing).

### 5.0 INSTALLATION REQUIREMENTS

In addition to the particular requirements given for the individual product, the following general requirements should be noted.

5.1 Where access to any part of equipment which moves, or can become electrically live are not prevented by the equipment panels or by fixed installation detail (eg ducting), then guarding to the appropriate standard must be fitted.

5.2 The electrical installation of the equipment must comply with the requirements of the relevant local electrical safety regulations.

5.3 For EMC all control and sensor cables should not be placed within 50mm or on the same metal cable tray as 230V switched live, lighting or power cables and any cables not intended for use with this product.

### 6.0 COMMISSIONING REQUIREMENTS

6.1 General pre-commissioning checks relevant to safe operation consist of the following:

Ensure that no foreign bodies are present within the fan or casing.

Check electrical safety. e.g. Insulation and earthing.

Check guarding of system.

Check operation of Isolators/Controls.

Check fastenings for security.

6.2 Other commissioning requirements are given in the relevant product documentation.

### 7.0 OPERATIONAL REQUIREMENTS

7.1 Equipment access panels must be in place at all times during operation of the unit, and must be secured with the original fastenings.

7.2 If failure of the equipment occurs or is suspected then it should be taken out of service until a competent person can effect repair or examination. (Note that certain ranges of equipment are designed to detect and compensate for fan failure).

### 8.0 MAINTENANCE REQUIREMENTS

8.1 Specific maintenance requirements are given in the relevant product documentation.

8.2 It is important that the correct tools are used for the various tasks required.

8.3 If the access panels are to be removed for any reason the electrical supply to the unit must be isolated.

8.4 A minimum period of two minutes should be allowed after electrical disconnection before access panels are removed. This will allow the impeller to come to rest.

**NB: Care should still be taken however since airflow generated at some other point in the system can cause the impeller to "windmill" even when power is not present.**

8.5 Care should be taken when removing and storing access panels in windy conditions.

Technical or commercial considerations may, from time to time, make it necessary to alter the design, performance and dimensions of equipment and the right is reserved to make such changes without prior notice.