

AXUS SVTC

300°C for 2hr High Temperature
Induction Centrifugal Fans

Installation and Maintenance

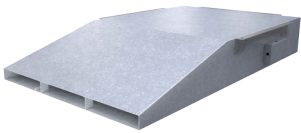

1.0 Introduction

The Nuair SVTC induction unit comprises a high temperature centrifugal fan enclosed in a galvanised steel casing.

The impeller shall be made from a welded and painted steel sheet.

The air intake of the SVTC is on the lower side. The air is conveyed over the motor and then directed towards a horizontal discharge nozzle at the front of the unit.

The electrical cable is specified for high thermal loads, protected against mechanical stresses, and connects to a metal isolator box placed on the casing side.

The units are designed for ceiling installation (hanging) and may only be fitted with the mounting brackets using certified anchoring bolts.

Figure 1. Unit Airflow

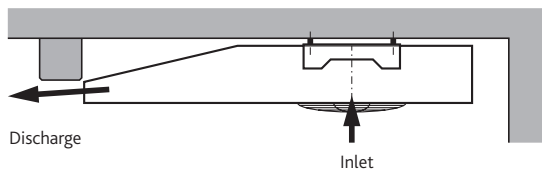

1.1 Fan Code Descriptions

SVTC 8-50-T8-G

1 2 3 4 5

- SVTC - Axus Induction Centrifugal Range
- Performance Range
- No Suffix = Single Speed Suitable for Frequency Inverter
T8 = 2 Speed 4/8 Pole
- No Suffix = 400V, 50Hz
G = 460V, 60Hz
J = 380V, 60Hz

The Nuair SVTC unit comprising fan/motor assembly shall be certified for high temperature operation at 300°C for 2 hours.

The range shall have been type tested to EN12101-3.

The units shall be either 2 speed or inverter driven providing, low speed for day to day environmental ventilation and one off operation for emergency ventilation (S1 duty).

The Nuair SVTC unit shall have an inlet guard for safety purposes and also to prevent debris being sucked through the fan.

EN12101-3 compliant, refer to EC certificate of conformity 0086-CPR-672476.

2.0 Handling

Always handle the units carefully to avoid damage and distortion. If mechanical aids are used to lift the unit, spreaders should be employed and positioned so as to prevent the slings, webbing etc. making contact with the casing.

3.0 Installation

Installation must be carried out by competent personnel in accordance with the appropriate authority and conforming to all statutory governing regulations.

Figure 2. Unit Installation

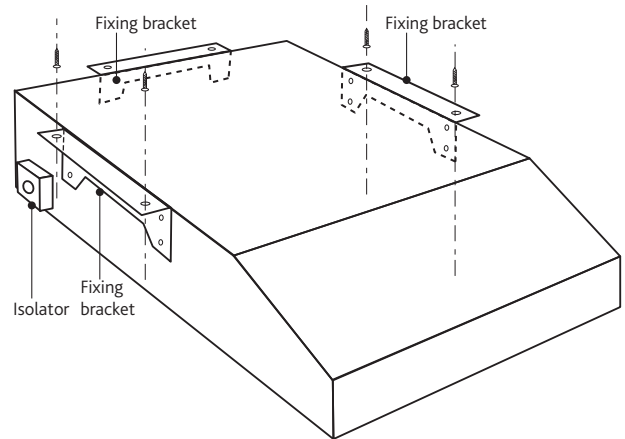

Raise the SVTC unit up into the chosen mounting position. Using the four holes in the top side of the two brackets either side of the unit attach the unit to the ceiling/support crossbars with certified anchoring bolts (see fig. 2). The rear mounted bracket is utilised in installations where drop rods are used to provide additional stability on fan startup.

4.0 Dimensions

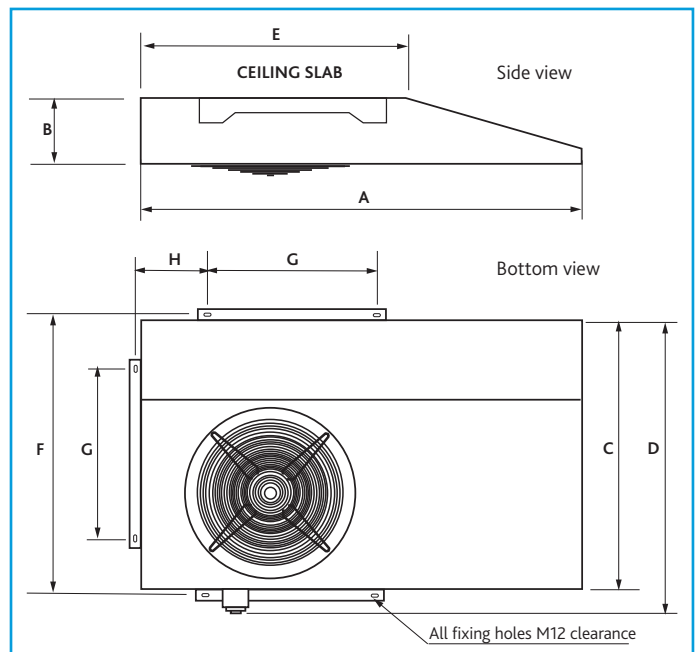

Model	A	B	C	D	E	F	G	H	Weight
SVTC-50	1265	226	790	893	710	844	448	234	100kg
SVTC-100	1900	278	1150	1260	1150	1204	730	319	195kg

5.0 Electrical Information

Motors are totally enclosed and protected to IP55 (Dust and low pressure water jets). Motors comply with BS5000, EN600034 and IEC34-1. Enclosures are to IP55 with class H insulation. Motors are tested in accordance with EN12101-3 2015. Take note of the maintenance requirements for the motor.

Failure to comply with the recommendations will invalidate any warranty claim.

5.1 Wiring

Electrical supply wiring connection is to an externally mounted isolator box on the case exterior. The box is pre-wired to the motor with heat resisting cable.

Figure 3.

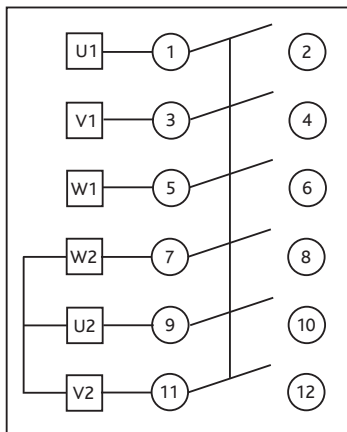

3 PHASE STAR CONNECTION (3kW & BELOW)

STAR

- L1 - U1
- L2 - V1
- L3 - W1

Figure 4.

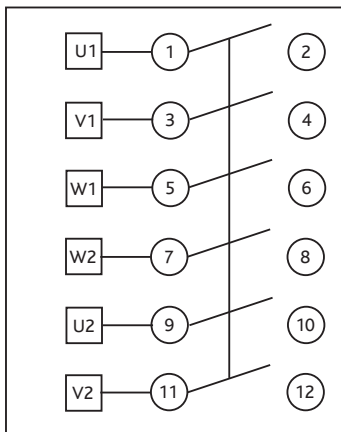

3 PHASE STAR / DELTA CONNECTION (4kW & ABOVE)

STAR

- L1 - U1
- L2 - V1
- L3 - W1

DELTA

- L1 - U1 - W2
- L2 - V1 - U2
- L3 - W1 - V2

LINK W2, U2, V2

Figure 5.

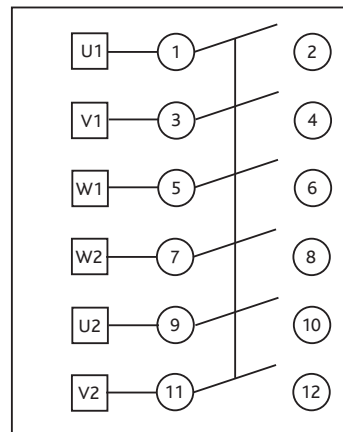

3 PHASE TWO SPEED TAP/PAM WOUND MOTORS (D.O.L STARTING BOTH SPEEDS)

HIGH SPEED

- L1 - 2U
- L2 - 2V
- L3 - 2W

LOW SPEED

- L1 - U1
- L2 - V1
- L3 - W1

LINK U1, V1, W1

N.B. Individual wiring instruction are included with each unit.

MATCHED FREQUENCY INVERTER

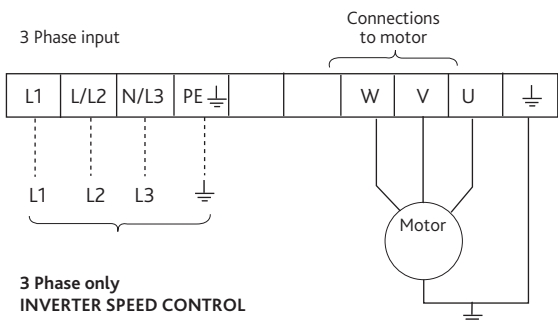

N.B. Total length of motor leads should not exceed 50 metres. If a screened motor cable is used, maximum length should be 25 metres. Consult our Technical Department if you wish to use longer leads. Inverters are configured to suit specific fans and control applications as described on the Customer Order free of charge.

IMPORTANT

For good EMC engineering practice, any sensor cables or switched live cables should not be placed within 50mm of other cables or on the same metal cable tray as other cables.

IMPORTANT

Before loosening bolts (2) of the motor impeller (3), care must be taken to prevent the unit from falling down e.g. by using a lifting device or elevating platform.

6.0 Start-up Procedure

Ensure that the impeller rotation follows the label arrow indicator on the casing. Should the direction be incorrect on three phase units, reverse any two of the supply leads. Care should be taken to set correct rotation as incorrect rotation may result in damage to the motor. Equipment should be run for approx. 30 minutes to ensure correct operation. If any fault occurs, the equipment should be switched off. **Do not re-start until the fault has been rectified.**

7.0 Maintenance

7.1 General

Nuaire recommends all products maintained in accordance with the HVCA "Standard Maintenance Specification for Mechanical Services in Buildings" - Volume II Ventilating and Air Conditioning.

For guidance only due to the different periods of operation from the time of installation and conditions of use, no rigid inspection and maintenance periods can be recommended. We suggest, therefore that the inspection and if necessary cleaning should be carried out at regular intervals of 1000 hours of operation or 3 months, whichever is the sooner. For a routine inspection, check the tightness of all nuts, keys, grub screws and end bolts etc. Remove any build-up of dirt or dust with a brush.

7.2 Motor / Impeller Inspection

If the motor or impeller has to be removed for cleaning the following procedures are recommended:

Inspection of the motor/impeller must be made by using the intake and discharge openings.

- Motor connection cables to be unfastened within metal isolator box (1).
- Taking care, feed the cable contact back into the unit casing.
- **Before loosening bolts (2) of the motor impeller (3) care must be taken to prevent the unit from falling down - e.g. by using a lifting device or elevating platform.**
- To remove motor/impeller - loosen bolts (2). See important note above.
- Remove impeller from unit (3) by lowering it out of casing.

The assembly is made in reverse order to above.

Figure 6. Removing and dismantling impeller.

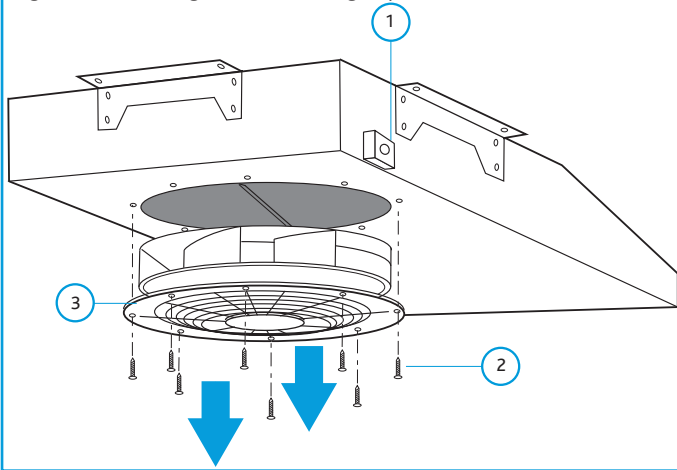

7.3 Ongoing Maintenance

Induction motors, by their very nature require minimal maintenance. However, a regular regime of inspection is recommended to ensure minor problems do not escalate into breakdowns. Typical intervals would be 1000 hours of operation or 3 months, whichever is the sooner.

7.4 Checklist

- No visible damage i.e. impeller cracked, fan cowl bent, foot cracked etc.
- No accumulation of dust or fibres on the frame or around the fan inlet.
- No significant corrosion of the lifting lugs/eyebolts.
- No excessive vibration.
- No loose fasteners.
- Cables and earths are sound.
- Sealing of the motor and gland plate are in good condition.
- Insulation resistance adequate, imperative this is checked after prolonged shutdown.

8.0 Specific Commissioning and Servicing Requirements

8.1 Motors for Smoke Extract Fans

Exposure temperature/time: 300°C for 120 minutes.

These motors are used to provide a SAFETY FUNCTION for people in the event of fire in public premises or in the home: they are therefore subject to strict constraints concerning their operating and maintenance.

8.2 Operating Constraints

- Check on the nameplate that the selected motor corresponds to the maximum exposure temperature and duration.**
- Non ventilated motors MUST be placed in the airflow from the driven fan. Ventilated motors can be placed outside the flow.**
- AFTER THE MOTOR HAS BEEN SUBJECTED TO ONE EMERGENCY DUTY OPERATION, IT MUST BE REPLACED.**
- With variable speed control. Ensure that the maximum speed never exceeds the speed of the motor supplied by the mains and that the delivered power corresponds to the previous definitions.

These qualifications ensure the qualification of the driven fan by the manufacturer.

9.0 Replacement of Parts

When ordering spares it is important to state the unit serial number to ensure that the correct spares will be supplied.

N.B. - Fixing bolts, nuts, studs, screws, spacers or washers are not included with these parts and if required, should be clearly specified on the order in addition to the part description number.

10.0 Warranty

The three year warranty starts from the day of delivery and includes parts and labour for the first year. The labour element is subject to full, free and safe access to the equipment as recommended by the CDM regulations. The remaining two years covers replacement parts only.

This warranty is void if the equipment is modified without authorisation, is incorrectly applied, misused, disassembled, or not installed, commissioned and maintained in accordance with the details contained in this manual and general good practice.

The product warranty applies to the UK mainland and in accordance with Clause 14 of our Conditions of Sale. Customers purchasing from outside of the UK should contact Nuair International Sales office for further details.

11.0 After Sales Enquiries

For technical assistance or further product information, please contact the After Sales Department. Contact must be made prior to any remedial action being taken under the warranty. Please quote the motor serial number in all such cases with detailed description of the problem.

Telephone 02920 858 400
aftersales@nuaire.co.uk

DECLARATION OF INCORPORATION AND INFORMATION FOR SAFE INSTALLATION, OPERATION AND MAINTENANCE

We declare that the machinery named below is intended to be assembled with other components to constitute a system of machinery. All parts except for moving parts requiring the correct installation of safety guards comply with the essential requirements of the Machinery Directive. The machinery shall not be put into service until the system has been declared to be in conformity with the provisions of the EC Machinery Directive.

Designation of machinery: AXUS SVTC Induction Fan
Machinery Types: High Temperature Centrifugal Fans
Relevant EC Council Directives: 2006/42/EC (Machinery Directive)
Applied Harmonised Standards: BS EN ISO 12100-1, BS EN ISO 12100-2, BS EN ISO 60204-1, BS EN ISO 9001, BS EN ISO 13857
Applied National Standards: BS848 Parts 1, 2.2 and 5

Signature of manufacture representatives:

Name:	Position:	Date:
1) C. Biggs 	Technical Director	27. 04. 16
2) A. Jones 	Manufacturing Director	27. 04. 16

Note: All standards used were current and valid at the date of signature.

INFORMATION FOR SAFE INSTALLATION, OPERATION AND MAINTENANCE OF NUAIRE VENTILATION EQUIPMENT

To comply with EC Council Directives 2006/42/EC Machinery Directive and 2014/30/EU (EMC). To be read in conjunction with the relevant product documentation (see 2.1)

- 1.0 GENERAL**
- 1.1 The equipment referred to in this Declaration of Incorporation is supplied by Nuairé to be assembled into a ventilation system which may or may not include additional components. The entire system must be considered for safety purposes and it is the responsibility of the installer to ensure that all of the equipment is installed in compliance with the manufacturers recommendations and with due regard to current legislation and codes of practice.
- 2.0 INFORMATION SUPPLIED WITH THE EQUIPMENT**
- 2.1 Each item of equipment is supplied with a set of documentation which provides the information required for the safe installation and maintenance of the equipment. This may be in the form of a Data sheet and/or Installation and Maintenance instruction. Each unit has a rating plate attached to its outer casing. The rating plate provides essential data relating to the equipment such as serial number, unit code and electrical data. Any further data that may be required will be found in the documentation. If any item is unclear or more information is required, contact Nuairé.
- 2.2 Where warning labels or notices are attached to the unit the instructions given must be adhered to.
- 3.0 TRANSPORTATION, HANDLING AND STORAGE**
- 3.1 Care must be taken at all times to prevent damage to the equipment. Note that shock to the unit may result in the balance of the impeller being affected.
- 3.2 When handling the equipment, care should be taken with corners and edges and that the weight distribution within the unit is considered. Lifting gear such as slings or ropes must be arranged so as not to bear on the casing.
- 3.3 Equipment stored on site prior to installation should be protected from the weather and steps taken to prevent ingress of contaminants.
- 4.0 OPERATIONAL LIMITS**
- 4.1 It is important that the specified operational limits for the equipment are adhered to e.g. operational air temperature, air borne contaminants and unit orientation.
- 4.2 Where installation accessories are supplied with the specified equipment e.g. wall mounting brackets. They are to be used to support the equipment only. Other system components must have separate provision for support.
- 4.3 Flanges and connection spigots are provided for the purpose of joining to duct work systems. They must not be used to support the ductwork.
- 4.4 **Local Environment - Humidity.** Ambient humidity (the humidity at the unit's installed location) shall be within the range: 10 to 95% (for controls, non-condensing). Air humidity (the humidity of the air passing through the unit) shall be within the range: 10 to 95% (for controls, non-condensing).

5.0 INSTALLATION REQUIREMENTS

- In addition to the particular requirements given for the individual product, the following general requirements should be noted.
- 5.1 Where access to any part of equipment which moves, or can become electrically live are not prevented by the equipment panels or by fixed installation detail (e.g. ducting), then guarding to the appropriate standard must be fitted.
- 5.2 The electrical installation of the equipment must comply with the requirements of the relevant local electrical safety regulations.
- 5.3 For EMC all control and sensor cables should not be placed within 50mm or on the same metal cable tray as 230V switched live, lighting or power cables and any cables not intended for use with this product.

6.0 COMMISSIONING REQUIREMENTS

- 6.1 General pre-commissioning checks relevant to safe operation consist of the following: Ensure that no foreign bodies are present within the fan or casing. Check electrical safety. e.g. Insulation and earthing. Check guarding of system. Check operation of Isolators/Controls. Check fastenings for security.
- 6.2 Other commissioning requirements are given in the relevant product documentation.

7.0 OPERATIONAL REQUIREMENTS

- 7.1 Equipment access panels must be in place at all times during operation of the unit, and must be secured with the original fastenings.
- 7.2 If failure of the equipment occurs or is suspected then it should be taken out of service until a competent person can effect repair or examination. (Note that certain ranges of equipment are designed to detect and compensate for fan failure).

8.0 MAINTENANCE REQUIREMENTS

- 8.1 Specific maintenance requirements are given in the relevant product documentation.
- 8.2 It is important that the correct tools are used for the various tasks required.
- 8.3 If the access panels are to be removed for any reason the electrical supply to the unit must be isolated.
- 8.4 A minimum period of two minutes should be allowed after electrical disconnection before access panels are removed. This will allow the impeller to come to rest.
- NB: Care should still be taken however since airflow generated at some other point in the system can cause the impeller to "windmill" even when power is not present.**
- 8.5 Care should be taken when removing and storing access panels in windy conditions.

Technical or commercial considerations may, from time to time, make it necessary to alter the design, performance and dimensions of equipment and the right is reserved to make such changes without prior notice.