



ecosmart
classic

XBOXER XBC

UNIT SIZES 10 - 65 WITH
ECOSMART CLASSIC (ES) OR BASIC CONTROL (BC)
INSTALLATION, OPERATING AND
MAINTENANCE INSTRUCTIONS



FOR THE COMPLETE VENTILATION SOLUTION



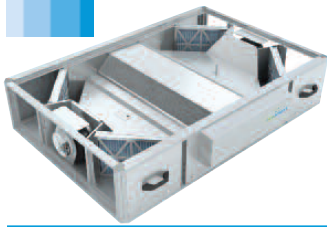

XBOXER XBC 10-65 (ES & BC Controls)

Supply & Extract Ventilation Unit with Heat Recovery Installation and Maintenance



The EMC Directive
2014/30/EU
The Low Voltage
Directive
2014/35/EU

1.0 Introduction

The information contained in this document provides details of installation, operation and maintenance for installers and users of the XBOXER XBC Supply and Extract Ventilation Unit with Heat Recovery.

This supply and extract air handling unit range comprises an combination of high efficiency centrifugal fans with EC motors, a Counterflow design plate heat exchanger, filters, optional heaters (LPHW and Electric) and a casing with high mass acoustic treatment.

A range of matched, close coupled attenuators with a similar construction method to that of the unit is available. The attenuators can be flipped for positioning on the left or right of the fan unit (see Figure 1) allowing flexibility for duct layout.

Attenuators are available in 1050, 1250 and 1600mm lengths and a matching attenuator flange is attached to the fan unit.

General information regarding performance and specifications for the equipment may be obtained from our Technical Literature, and/or project specific documentation.

Figure 1. Layout Overview of the XBC unit viewed from above and shown with matched room side and atmospheric side attenuators. Access for maintenance and inspection of the standard XBOXER XBC units is from the side of the unit.

Code description: XBOXER XBC Ventilation Unit

XBC 45 - H - L - ES - WP - R - BA
 1 2 3 4 5 6 7 8

1. XBOXER XBC Range
2. Unit size 10, 15, 25, 45, 55 and 65
3. H = Horizontal Side by Side layout
4. N = No Heater
L = LPHW Heater
E = Electric Heater
5. ES = Ecosmart Control
BC = Basic Control
6. WP = Separate Matched Weather Roof if required
7. R = Opposite arrangement (control box, heater battery and condensate pipe connection on opposite side)
8. BA = Bottom access (filter only, see section 2.0)
CP = Constant Pressure

Code description: Matched Combined Attenuator

XBC 25 - HS - MS10
 1 2 3 4

1. XBOXER XBC Range
2. Unit size 10, 15, 25, 45, 55 and 65
3. HS = Horizontal Supply/Discharge Attenuator
HE = Horizontal Extract/Intake Attenuator
4. MS10 = 1050mm Attenuator
MS12 = 1250mm Attenuator
MS16 = 1600mm Attenuator

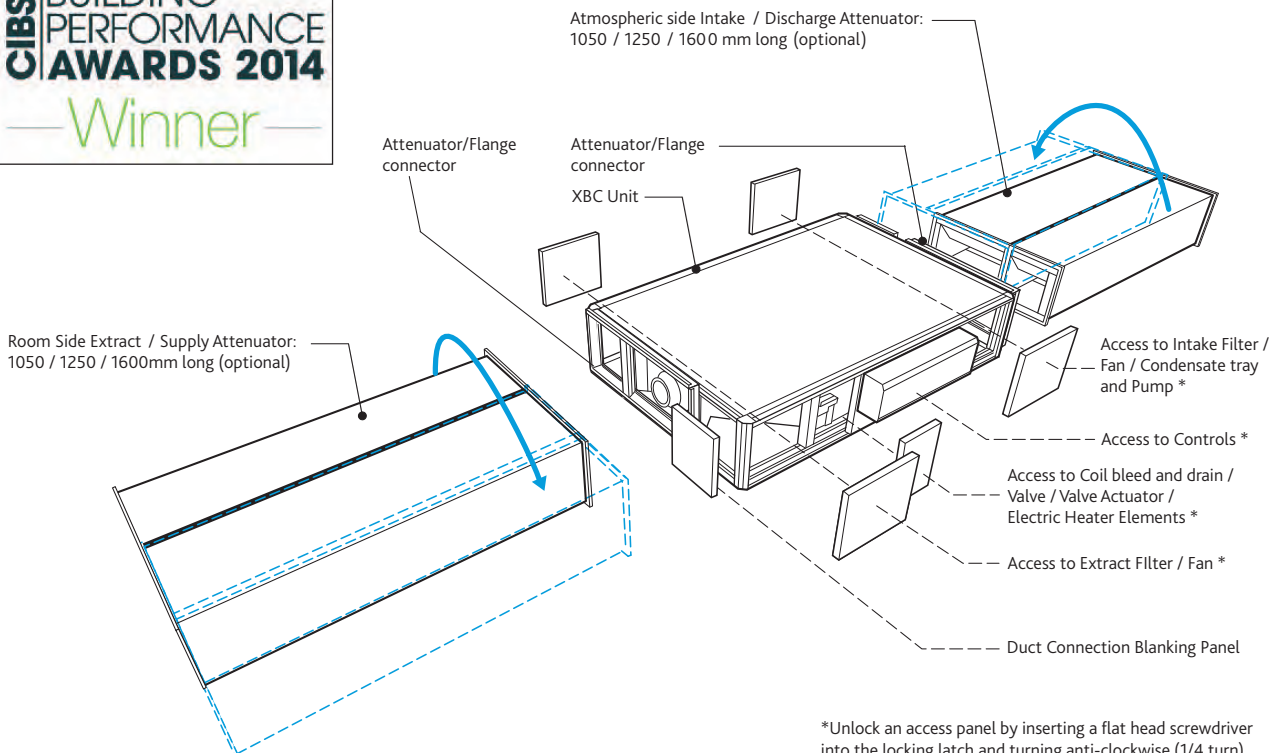

*Unlock an access panel by inserting a flat head screwdriver into the locking latch and turning anti-clockwise (1/4 turn).
Note: Bottom access unit (BA) Filters cannot be accessed from the side of the unit.

2.0 XBOXER XBC Unit Access Concepts

In this product range, several unique concepts have been implemented with a view to simplifying the installation design.

1. The unit configuration is such that the supply and discharge connections are positioned on the unit centre line. The corresponding Intake and Extract connections may be positioned on either side of the unit, allowing greater flexibility in the layout of ductwork in the space, (Figure 3) with the blanking panel re-positioned to suit.
2. The standard Ecosmart XBC unit configuration is shown below. **Unit handing information will not be requested for this range**, and units will be supplied in this format as standard.
3. The unit must be installed with at least 250mm clearance from a wall / barrier. With this absolute minimum clearance, the unit may be connected to the power supply and control connections since the control may be rotated by 90 degrees to face downwards. (Note: - cable connections must allow for the relative movement when the control is re-positioned).
4. With this clearance, unit filters may be changed, and the fans coils, heat exchanger and condensate tray may be inspected and cleaned if necessary.
5. The LPHW and Electrical heater settings, coil bleed and drain, and all other control adjustments are similarly accessible (see Figure 1).
6. Side access, where possible, is preferred in all cases in terms of safe working access to the equipment under the CDM regulations.
7. Note however, that access in the situation is difficult and does not allow for major maintenance including component replacement. Nuair recommend as best practice guidance, to allow for a minimum of around 600mm clearance (as stated in ADF 2010).
8. Where these arrangements are not suitable, the Consultant's and Contractor's project specific requirements will always be accommodated where possible.
9. Bottom access only units (Example

code: XBC15-H-LES BA), provide access to filters only (see Figure 6).

Filter removal is not available from the sides on these units. Bottom access units must be installed with the following minimum clearance below the units.

XBC15 = 225mm, XBC25 = 300mm XBC45 = 360mm.

Note: Bottom access is not available on XBC55 or XBC65 units.

Figure 2. The control side of the unit must be installed with at least 250mm clearance from a wall / barrier to gain access from the side.

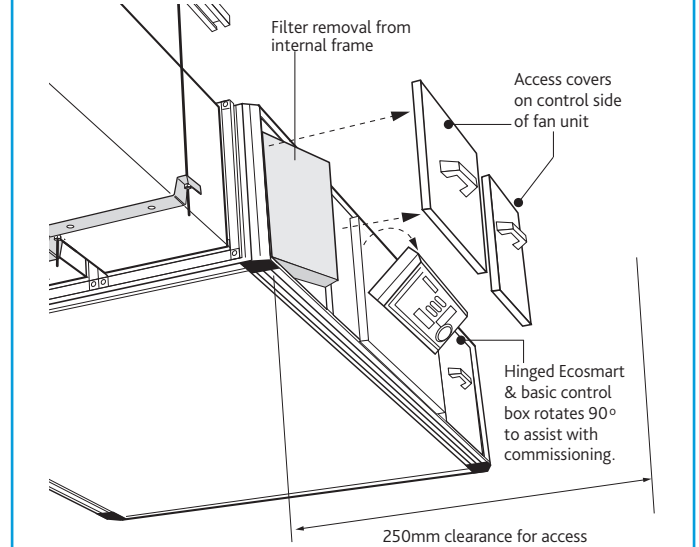

IMPORTANT

Unlocking an access panel is achieved by inserting a flat head screwdriver into the locking latch groove and turning anti-clockwise (1/4 turn), keys are neither required nor provided by Nuair.

Figure 3. Selectable Duct Connections (Top view).

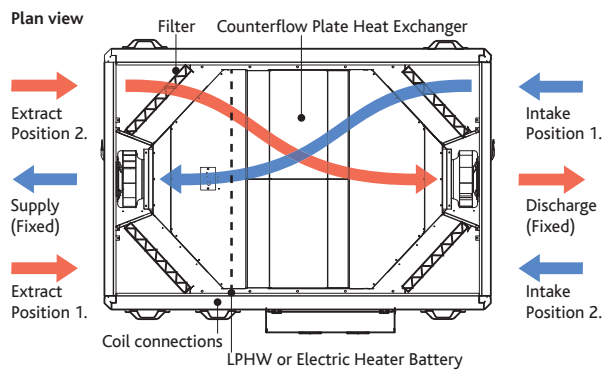

Note: The unit is shipped with four G4 filters in place, two of which are included as spares. For F7 filters contact Nuair.

Figure 4. Standard Unit Format (Top view).

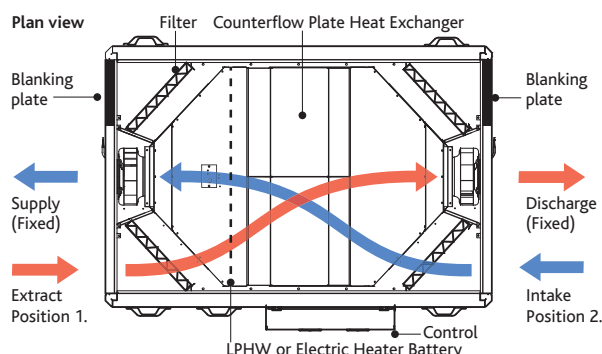

Figure 5. Opposite unit arrangement (R) side access (Top view).

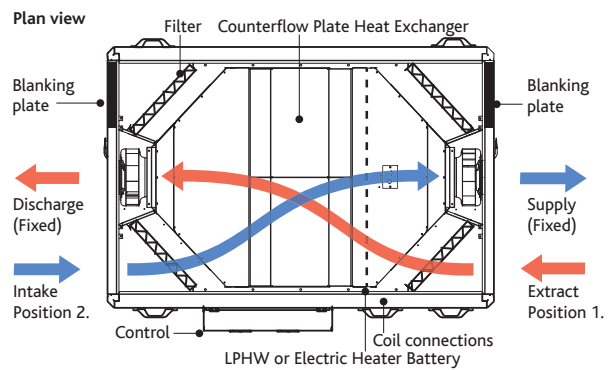
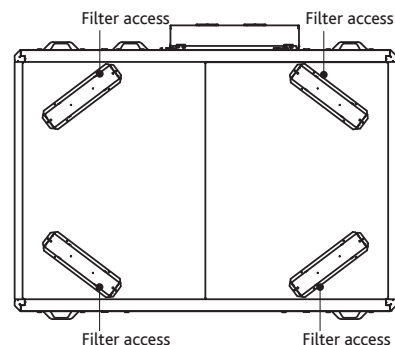

Figure 6. Bottom access only unit (Example code: XBC15-H-LES-BA).



IMPORTANT

Safety first! – Before commencing any work ensure:

- That all appropriate risk assessments have been carried out and the required safety measures have been taken.
- That you understand the work required.
- That you are trained and competent to carry it out.

3.0 Delivery of Equipment

3.1 Receipt of equipment

All equipment is inspected prior to despatch and leaves the factory in good condition. Upon receipt of the equipment an inspection should be made and any damage indicated on the delivery note.

Particulars of damage and/or incomplete delivery should be endorsed by the driver delivering the goods before offloading by the purchaser.

No responsibility will be accepted for damage sustained during the offloading from the vehicle or on the site thereafter.

All claims for damage and/or incomplete delivery must be reported to Nuair within two days of receipt of the equipment.

3.2 Offloading and Handling from the delivery Vehicle

The weight of the unit modules and palletised items is displayed on the unit rating plate or on the packaging. Some of the modules have an uneven weight distribution, and this will be indicated by labelling where appropriate. Ensure that lifting and handling equipment is adequately rated.

Offloading and positioning of the equipment is the responsibility of the purchaser.

Spreaders should be used when lifting with slings to avoid damage to the casings. Care must be taken to ensure that slings are correctly positioned to avoid crushing and twisting of the unit castings.

Where channels and/or support frames are bolted to the underside of the unit casing, slings or fork-lift arms should be positioned to locate in the apertures in the channels. If lifting eyes have been supplied / fitted it is recommended that they are used.

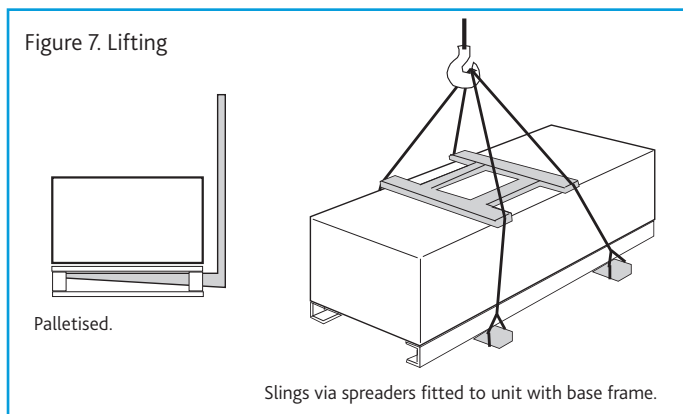

XBOXER XBC unit sections will be delivered to site in one section.

Each Section will be labelled with the direction of air flow.

The direction convention must be observed during assembly.

The unit may only be operated in its intended horizontal installation plane.

The unit must be fully levelled during installation (this is essential to ensure that condensate drains correctly).

See "Dimensions and Weights" on page 5 for dimensions and weights.

3.3 Storage

The equipment must be stored in a dry, internal location. Ductwork connection apertures shall be sealed against the ingress of dust, water and vermin.

If the storage period is to exceed two months, contact Nuair for guidance on the appropriate "mothballing" procedures.

Do not stack units, modules or components.

4.0 Erection and Assembly

Units must be installed in accordance with good industry practice.

These units may only be mounted horizontally and must be fully levelled in the horizontal plane. The units are heavy, and should be mounted using the fixing brackets supplied or other suitable methods of support. The supporting structure must be assessed for structural suitability.

Heat recovery components and modules that incorporate cooling coils may produce condensation during use. An insulated drip tray and condensate pump is provided. The drain connection must be connected to a suitable drainage point (see Figure 22 on page 13 for details).

4.1 Condensate Pump Alarm

The condensate pump incorporates an alarm function. If the water level in the condensate tray exceeds a maximum level (for example, as a result of the discharge tube becoming blocked or frozen), the alarm contact will open. This contact is internally connected to the heat exchanger bypass actuator, and the unit will automatically be placed into bypass mode, preventing further condensate production. Unit operation will otherwise be unaffected.

Condensate pump specification

Maximum flow rate = 12 l/h

Maximum head = 20m Vertical, 100m Horizontal

Pipe Connection size (Condensate) XBOXER XBC = 8 mm

LPHW Coils, if fitted, are tested during manufacture to 16 Bar (using dry compressed air). Coil and valve assemblies are similarly tested to 10 Bar. Operation of standard equipment is rated at PN6, if the intended system requires higher operating pressures; please contact the Nuair Technical department for advice.

Electrical connections to the unit shall be made in accordance with the appropriate product (see below); and installation wiring diagrams, and shall use appropriately sized and rated cables.

Only the prepared apertures in the unit casing may be used for cable entry. Do not drill or cut the unit casing for this purpose. Cable access points are provided at the ends of the control enclosure.

If the control is rotated to aid connection of cables, please ensure that sufficient flexibility is provided in the final connection run.

N.B. To avoid conflict with the unit access panels, it is recommended that electrical and plumbing service connections to the unit are run at 90 degrees to the main air flow axis.

Control circuit connections must be segregated (i.e. routed separately) from power connections.

The unit rating label shows the maximum electrical load of the equipment. Connections to the unit may include single phase supply connections, and a variety of control circuits.

Only the prepared apertures in the unit casing may be used for cable entry. Do not drill or cut the unit casing for this purpose.

The equipment must be earthed and earth-bonded. Means of local isolation for maintenance purposes are generally required (by others). Ensure that all mains connections are isolated.

5.0 Dimensions and Weights

5.1 XBOXER XBC (ES and BC) Unit Dimensions (mm) and Weights (kg)

Figure 8. Standard unit dimensions (mm) and weights (kg).

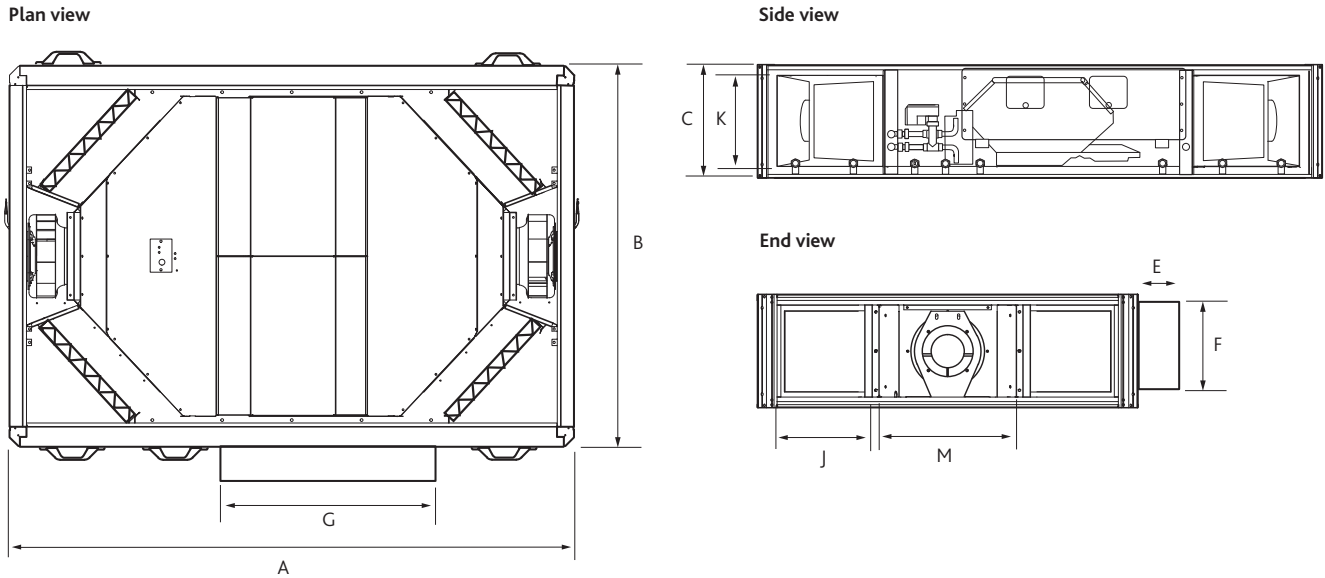

Unit Code	Unit Dimensions (mm)						Control Dimensions (mm)			Unit Weights (kg)	Packed Weights (kg)
	A	B	C	J	K	M	E	F	G		
XBC10-H-LES	1600	1000	260	238	220	347	120	200	670	145	195
XBC10-H-NBC	1600	1000	260	238	220	347				141	191
XBC15-H-LES	1600	1000	260	238	220	347	120	200	670	187	237
XBC15-H-NBC	1600	1000	260	238	220	347				183	233
XBC25-H-LES	1700	1150	340	252	302	471	120	200	670	235	285
XBC25-H-NBC	1700	1150	340	252	302	471				231	281
XBC45-H-LES	1900	1250	400	270	360	531	120	200	670	291	391
XBC45-H-NBC	1900	1250	400	270	360	531				287	387
XBC55-H-LES	1900	1560	470	398	430	588	120	200	670	368	418
XBC55-H-NBC	1900	1560	470	398	430	588				364	414
XBC65-H-LES	1900	1560	620	398	580	588	120	200	670	469	619
XBC65-H-NBC	1900	1560	620	398	580	588				465	615

2 attenuator flange connections are attached to every unit. Add 50mm to dimension 'A' to include both flanges.

5.2 XBOXER XBC Unit Hanging Bracket Positions

Figure 9. Plan view of unit with 4 hanging brackets attached (two each side of the unit).

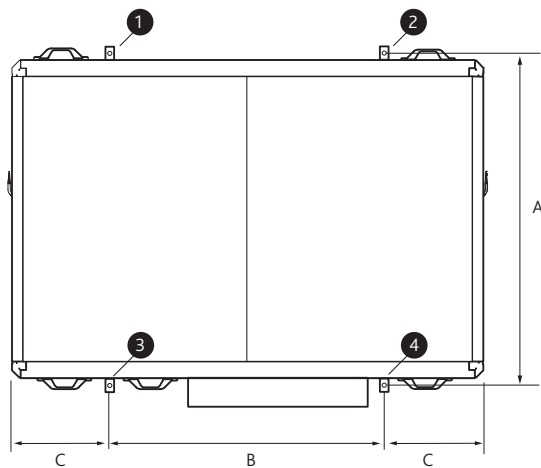

Unit Code	Dimensions to Hole Centres (mm)		
	A	B	C
XBC10-H-LES	1059	858	371
XBC15-H-LES	1059	858	371
XBC25-H-NBC	1207	888	406
XBC45-H-NBC	1309	1008	446
XBC55-H-NBC	1619	1058	421
XBC65-H-NBC	1619	1058	421

Compatible with 20mm Mez.

5.3 XBOXER XBC Attenuator Flange Connector Dimensions (mm)

Figure 10. Attenuator flange connector dimensions.

XBC10 & 15 Flange Connector

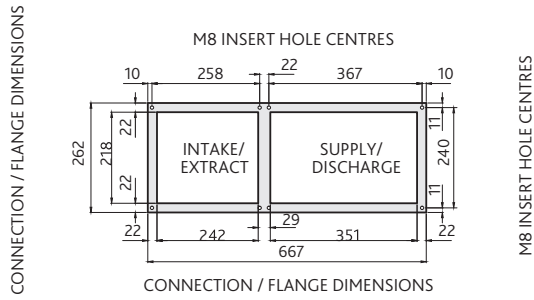

XBC25 Flange Connector

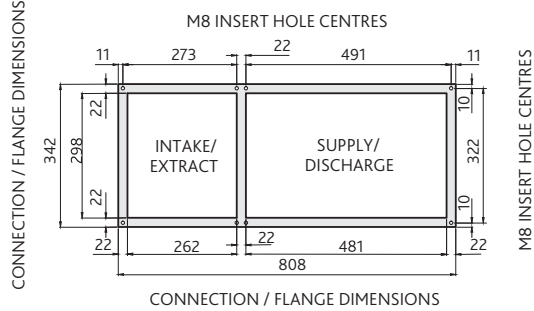

XBC45 Flange Connector

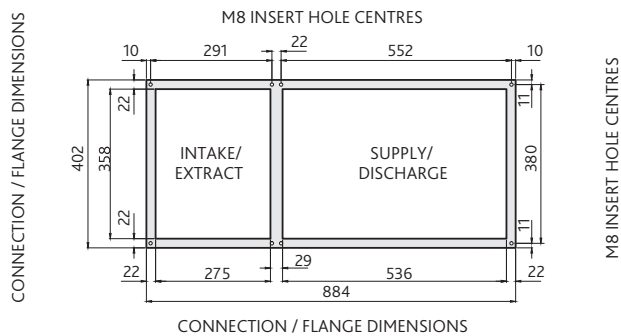

XBC55 Flange Connector

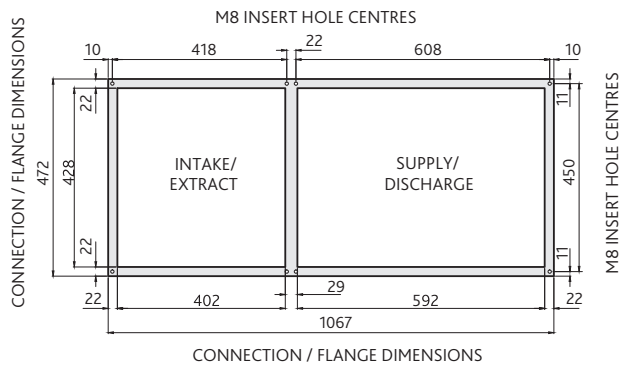

XBC65 Flange Connector

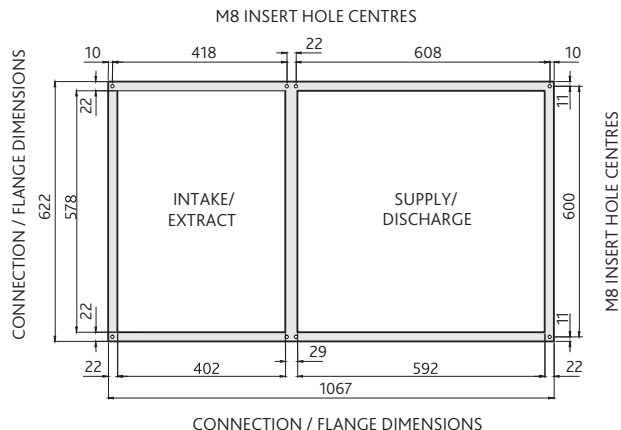

Hole centres.

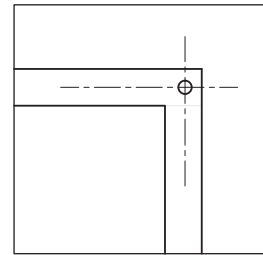

Compatible with 20mm Mez.

Note: The flange connector leaves factory attached to unit.

5.4 XBOXER XBC Attenuator Dimensions (mm) and Weights (kg)

Figure 11. Attenuator dimensions (mm).

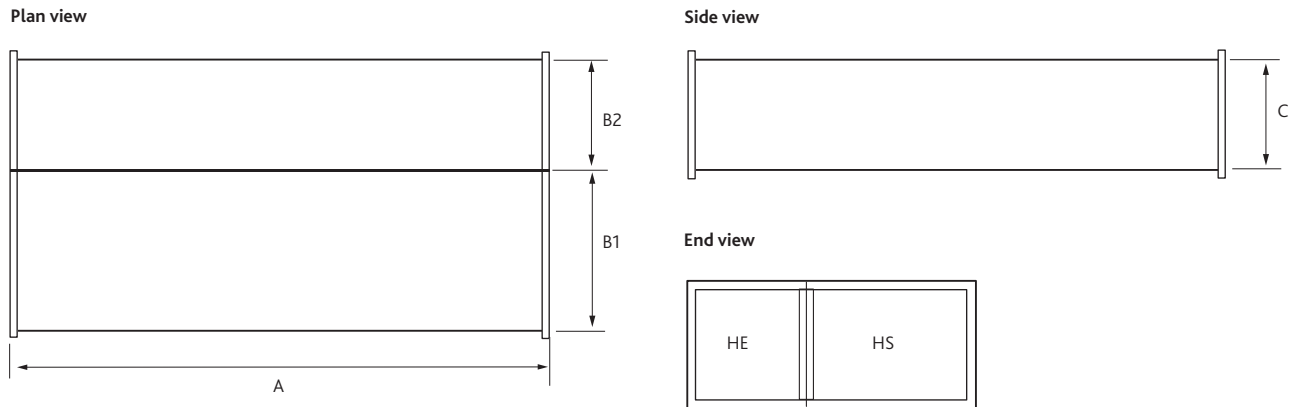

Attenuator Code	Dimensions (mm)				Attenuator Weights (kg)
	A	B1	B2	C	
XBC15-HS-MS10*	1050	347		220	30
XBC15-HE-MS10*	1050		238	220	24
XBC15-HS-MS12*	1250	347		220	35
XBC15-HE-MS12*	1250		238	220	29
XBC15-HS-MS16*	1600	347		220	44
XBC15-HE-MS16*	1600		238	220	36
XBC25-HS-MS10*	1050	471		302	29
XBC25-HE-MS10*	1050		252	302	29
XBC25-HS-MS12*	1250	471		302	34
XBC25-HE-MS12*	1250		252	302	34
XBC25-HS-MS16*	1600	471		302	42
XBC25-HE-MS16*	1600		252	302	42
XBC45-HS-MS10*	1050	531		360	32
XBC45-HE-MS10*	1050		270	360	32
XBC45-HS-MS12*	1250	531		360	40
XBC45-HE-MS12*	1250		270	360	37
XBC45-HS-MS16*	1600	531		360	47
XBC45-HE-MS16*	1600		270	360	47
XBC55-HS-MS10*	1050	588		430	32
XBC55-HE-MS10*	1050		398	430	36
XBC55-HS-MS12*	1250	588		430	37
XBC55-HE-MS12*	1250		398	430	42
XBC55-HS-MS16*	1600	588		430	47
XBC55-HE-MS16*	1600		398	430	52
XBC65-HS-MS10*	1050	588		580	43
XBC65-HE-MS10*	1050		398	580	46
XBC65-HS-MS12*	1250	588		580	51
XBC65-HE-MS12*	1250		398	580	54
XBC65-HS-MS16*	1600	588		580	63
XBC65-HE-MS16*	1600		398	580	67

2 attenuator flange connections are attached to every unit. Add 50mm to dimension 'A' to include both flanges.

5.5 XBOXER XBC Bend Attenuator Dimensions (mm) and Weights (kg)

Figure 12. Bend attenuator dimensions (mm).

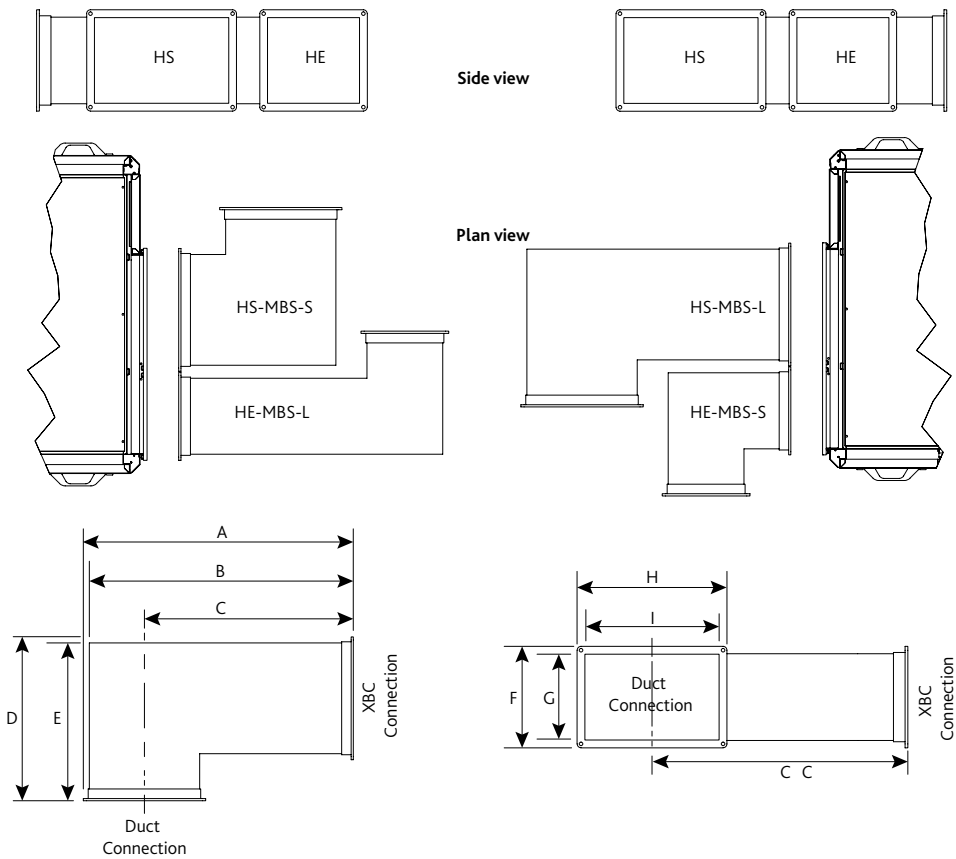

Attenuator Code	Unit Dimensions (mm)									Attenuator Weights (kg)
	A	B	C	D	E	F	G	H	I	
XBC15-HS-MBS-S	515	496	322	515	496	260	220	386	346	20
XBC15-HS-MBS-L	852	833	659	515	496	260	220	386	346	29
XBC15-HE-MBS-S	406	387	268	406	387	260	220	277	237	14
XBC15-HE-MBS-L	852	833	714	406	387	260	220	277	237	23
XBC25-HS-MBS-S	640	621	385	640	621	342	302	511	471	32
XBC25-HS-MBS-L	992	973	737	640	621	342	302	511	471	44
XBC25-HE-MBS-S	421	402	275	421	402	342	302	292	252	17
XBC25-HE-MBS-L	992	973	846	421	402	342	302	292	252	32
XBC45-HS-MBS-S	700	681	415	700	681	400	360	571	531	39
XBC45-HS-MBS-L	1070	1051	785	700	681	400	360	571	531	55
XBC45-HE-MBS-S	439	420	284	439	420	400	360	310	270	19
XBC45-HE-MBS-L	1070	1051	915	439	420	400	360	310	270	38
XBC55-HS-MBS-S	756	737	443	756	737	470	430	627	587	48
XBC55-HS-MBS-L	1253	1234	940	756	737	470	430	627	587	72
XBC55-HE-MBS-S	566	547	348	566	547	470	430	437	397	31
XBC55-HE-MBS-L	1253	1234	1035	566	547	470	430	437	397	58
XBC65-HS-MBS-S	756	737	443	756	737	620	580	627	587	54
XBC65-HS-MBS-L	1253	1234	940	756	737	620	580	627	587	82
XBC65-HE-MBS-S	566	547	348	566	547	620	580	437	397	36
XBC65-HE-MBS-L	1253	1234	1035	566	547	620	580	437	397	68

Coding:

HS - Denotes the type of silencer required for the supply or discharge.

HE - Denotes the type of silencer required for the extract or intake.

*Note: XBC15 silencers are also suitable for XBC10 units.

6.0 Installing the XBC Fan Units and Attenuators

The ventilation unit must be installed first—with consideration made for the length of the associated attenuators.

Installation of the XBOXER XBC units, including all external services and controls should be installed in accordance with the appropriate site procedures, and MUST conform to all governing regulations e.g. CDM, CIBSE, IEE, and in strict accordance with the applicable Building Regulations.

The correct installation position for the units shall be decided with due regard to access and maintenance requirements, and the objective of minimising the system ductwork resistance.

The recommended installation method is to use standard Unistrut channel secured to the slab / steelwork above the unit.

Four suitable drop rods should be secured to the Unistrut channel and extended to be fixed to the unit's four mounting brackets, (two each side of the fan unit) or to other horizontal supports by others where wider load distribution is required.

6.1 Installing the Attenuators

It is recommended that additional Unistrut channels are used to support the matched attenuators. M8 Drop rods should be secured to the Unistrut channel and extended to be fixed to the four piece support brackets to be used on the underside of the attenuators (see Figure 14).

Note – once the attenuators are supported and levelled, and immediately before securing the attenuator to the attenuator flange connector, remove the backing from the Foam Sealing Strip.

The attenuators must be secured to the unit using the screws provided.

Figure 13. Installing the fan unit.

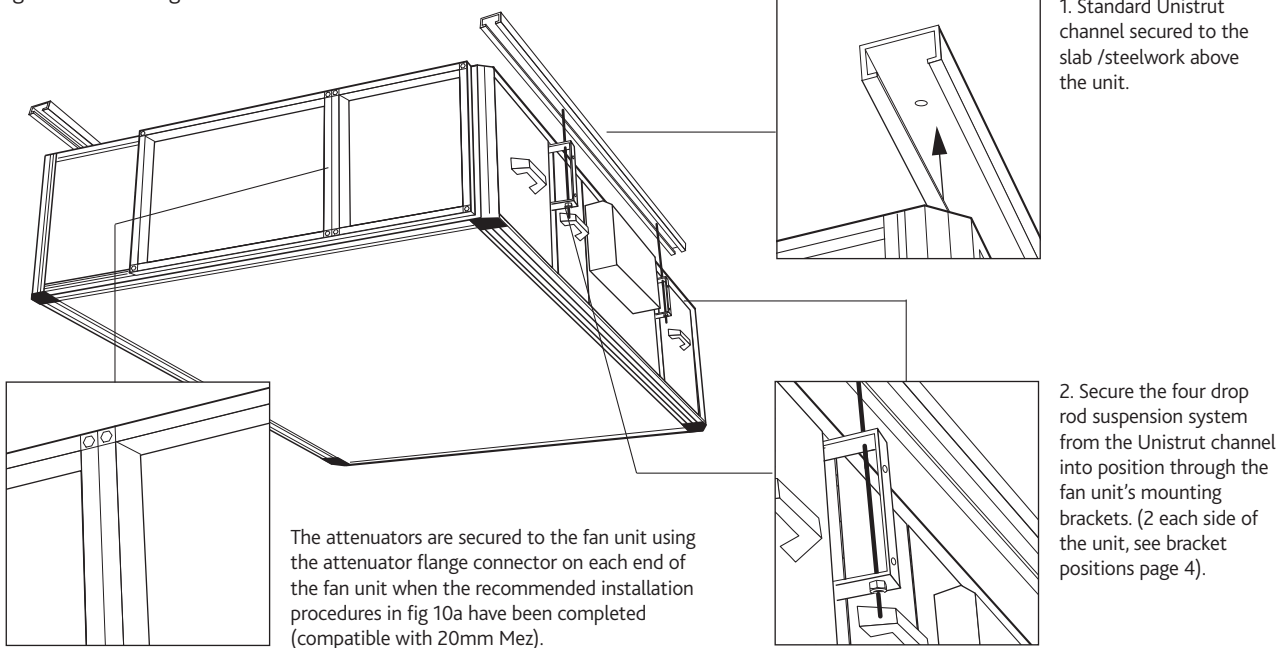
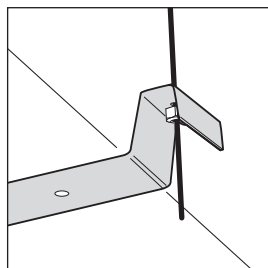

Figure 14. Installing the unit attenuators.

1. Secure standard Unistrut channel to the slab/ steelwork above the attenuators.
2. Secure M8 drop rods from the Unistrut channel into position.
3. Raise up the attenuator into position and attach the four piece support brackets onto the drop rods. (2 on each attenuator).
4. Utilising the 2 x 5.6mm dia holes in each bracket use relevant self tapping screws to fix into position on the underside of the attenuators.
5. Immediately before securing the attenuator to the connector, remove the backing from the Foam Sealing Strip.
6. Secure the attenuators to the attenuator flange connector on the end of the fan unit. (see fig 10).



6.2 Installing the XBC Weatherproof Roof on Ecosmart (ES) and Basic Control Fan Units (BC)

Having installed the ventilation unit and attenuators, the Weatherproof Roof can now be installed if required.

The Roof assembly and control cover must be secured to the unit using the fixing channel provided.

When the roof has been installed onto the fan unit please ensure that the edges of the roof are fully sealed where it joins the fan unit. This does not apply to the control cover as this will have to be removed if necessary.

Weatherproof Components

Item	Description	Quantity
A	Roof Assembly	1
B	Control Cover	1
C	Fixing Channel	

Optional Exhaust and Inlet Terminals

Item	Description	Quantity
D	Exhaust RT	1
E	Inlet RT	1

Unit Codes for Optional Exhaust and Inlet Terminals

XBC10-EXHAUST-RT
XBC10-INTAKE-RT
XBC15-EXHAUST-RT
XBC15-INTAKE-RT
XBC25-EXHAUST-RT
XBC25-INTAKE-RT
XBC45-EXHAUST-RT
XBC45-INTAKE-RT
XBC55-EXHAUST-RT
XBC55-INTAKE-RT
XBC65-EXHAUST-RT
XBC65-INTAKE-RT

Figure 15. Installing the weatherproof roof, exhaust and intake terminals.

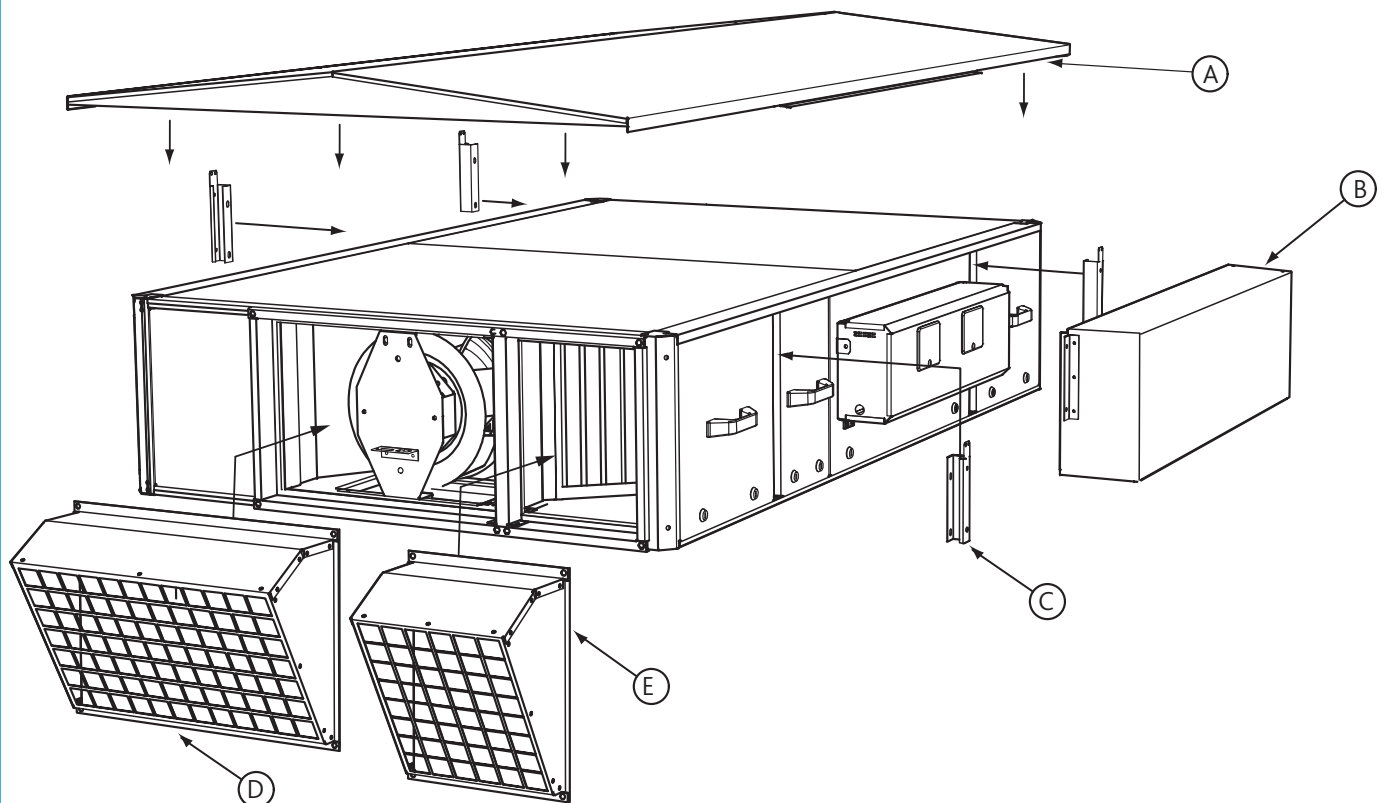

6.3 XBC Motorised Dampers

Internal version (example code: XBC15-MD).

External weather proof version (example code: XBC15-MD-WP).

If matching length Nuaire silencers (example codes: XBC15-HS-MS16 & XBC15-HE-MS16) are being fitted to the fan unit, the motorised damper (example code XBC15-MD) should be fitted after the silencers (as Figure 16). This ensures that breakout noise levels are kept to a minimum.

Where unmatched silencers are being fitted to the fan unit, the motorised damper should be fitted before the silencers.

The motorised damper units will be supplied loose and are designed to fit directly onto the flange connector (by others).

- Fully interlocking parallel blades, half inch diameter electroplated mild steel spindle.
- Nylatron bushes and external nylon/aluminium blade interconnection linkage.
- Fitted with Belimo SM230A-S drive open/drive close actuator complete with switch.
- Motorised damper wiring will require connection on site and possible extension of the cable looms.

Figure 16. Motorised damper installation options.

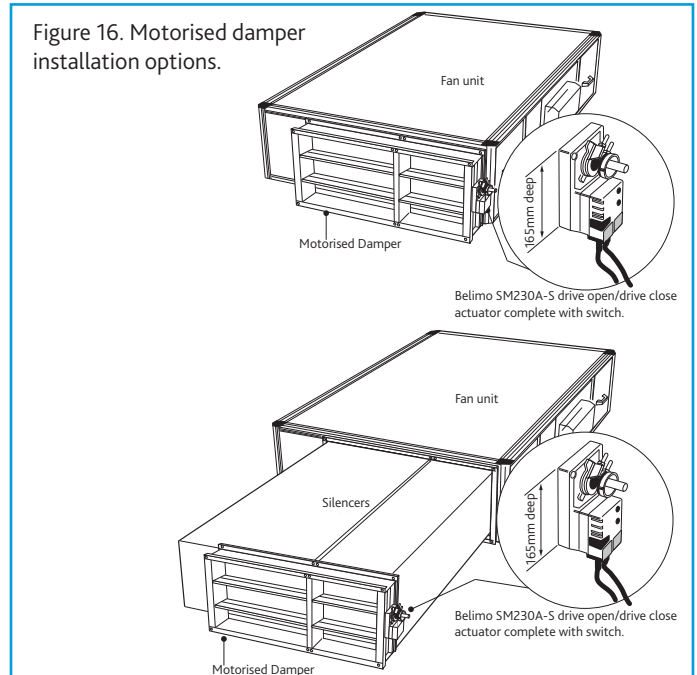

6.4 Constant Pressure Range (CP) - Controlling Static Pressure at Fan Inlet

Ecosmart constant pressure extract fans are supplied to control the static pressure at the fan inlet.

This set up is suitable for the majority of applications. When ancillaries with high pressure losses are fitted to the inlet side of the fan, the low pressure tapping must be moved from the fan chamber to a location upstream of the ancillaries, as shown below in Figure 18.

Failure to do this will result in excessive pressure being applied to the dampers at the rooms when the system is running in trickle mode.

Figure 17. Motorised damper wiring connections.

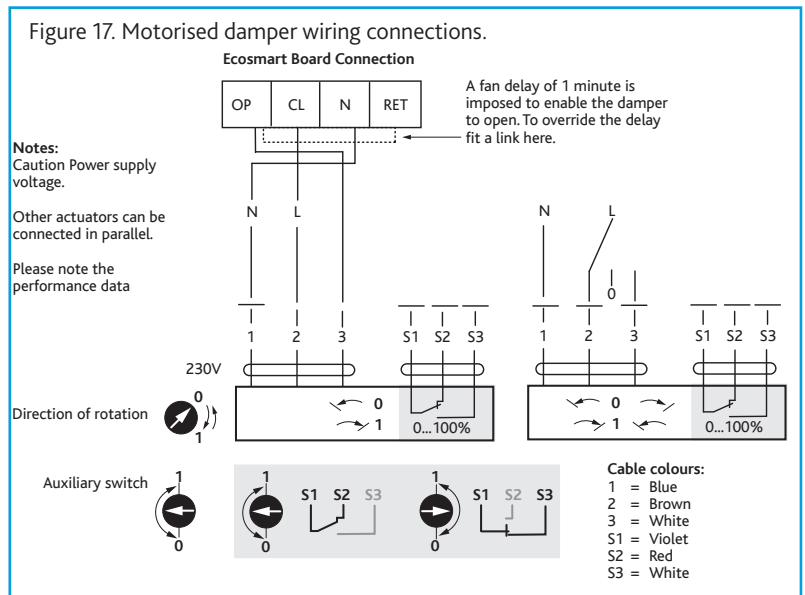
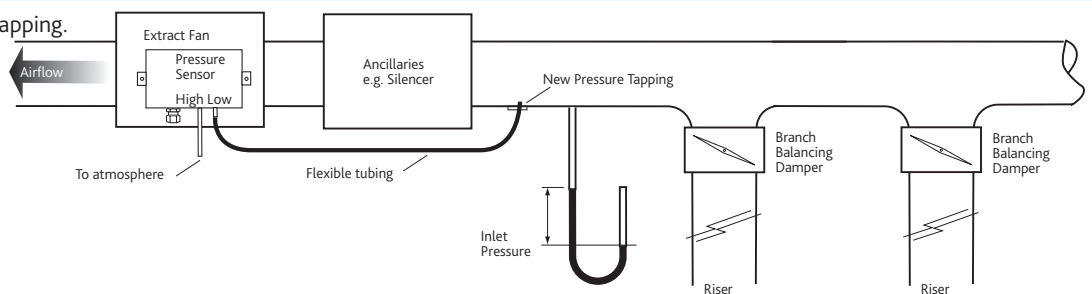

Figure 18. Constant pressure tapping.



6.5 Dirty Filter Pressure Switch

XBC units come with pre fitted pressure tapplings for use with the dirty filter alarms (supplied loose) on both the supply and extract air streams. The IP54 pressure switch is equipped with a red visual LED alarm which will illuminate when the pressure reading surpasses that set by the adjustable knob.

6.5.1 Mounting the Switches

Using the four mounting lugs provided, mount the pressure switches to a flat vertical surface using fixings appropriate for the surface. Any fixings used must have a maximum diameter of 8.0 mm. Do not tighten the fixings so much that the base of the device is deformed.

6.5.2 Connecting Pressure Tubing

IMPORTANT

Pressure tubing must not be kinked. Pay particular attention to this point if running hoses over an edge, it is better to form a loop.

For connection to the pressure switch, two fittings inherent in the housing are provided for hoses with an internal diameter of 6.0 mm.

- Connect a hose from the after filter (AF) pressure tapping to socket P1 which is located on the lower section of the housing.

- Connect a hose from the before filter (BF) pressure tapping to socket P2 which is located on the middle section of the housing.

After you have installed the hoses, it is absolutely essential to check them for tightness of fit at the connection points and to make sure that they run without any kinks.

6.5.3 Wiring

The cable gland is designed for cables with alternative sheath diameters of 7 mm or 10 mm. Only use these sizes. Otherwise the screw cable connection cannot seal adequately. The connections are intended for crimp-type sockets, 6.3 mm.

- Remove switch cover.
- Wire the main unit to the terminal block within the switch as per the below wiring diagrams (see Figure 19) ensuring the feed line is fused to suit Max 1.5A / 250 Vac.
- Refit switch cover.

6.5.4 Setting Switch Pressure

Make absolutely certain that there is no voltage on the electrical connections before you carry out any setting on the pressure switch, there is the possibility of an electric shock if you accidentally touch live parts.

Nuaire recommend the pressure switch be set to trigger when the filters experience a 125 Pa increase above the clean filter resistance for the largest commissioned airflow rate. Use the adjustment dial to set the pressure at which the switch will trip. When the pressure falls below this set value, the switch returns to its resting position.

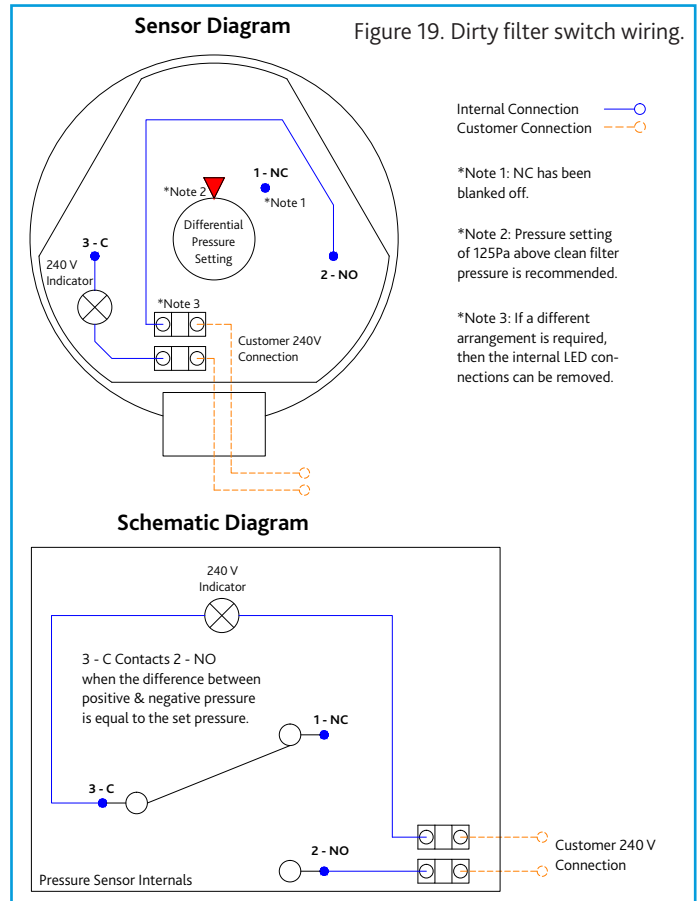

Figure 20. Access side view of pressure tapping layout of units with standard handing.

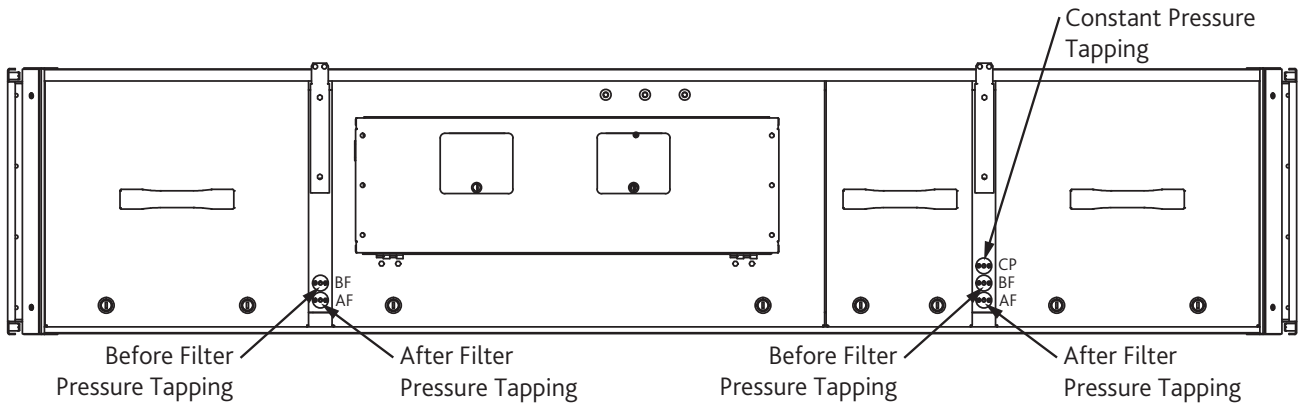

Figure 21. Access side view of pressure tapping layout of units with opposite handing.

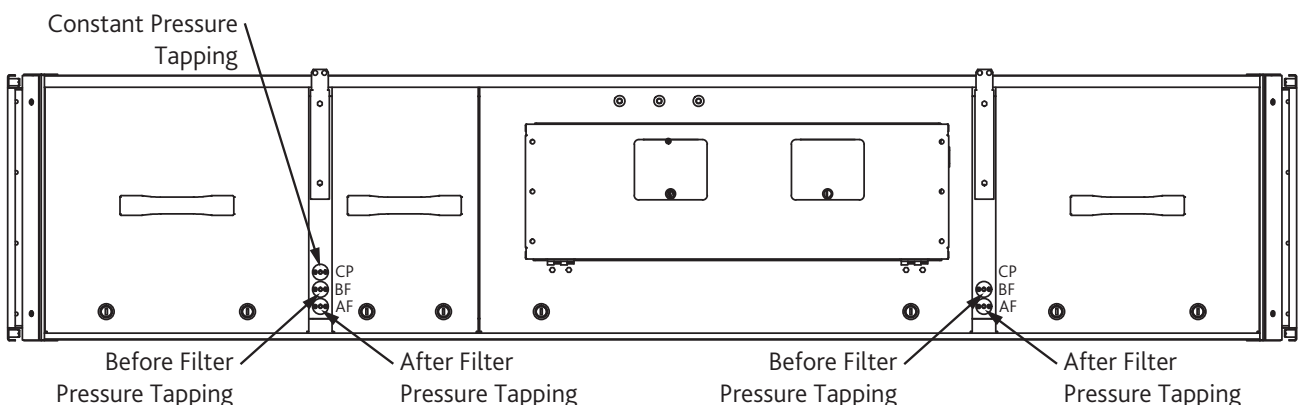
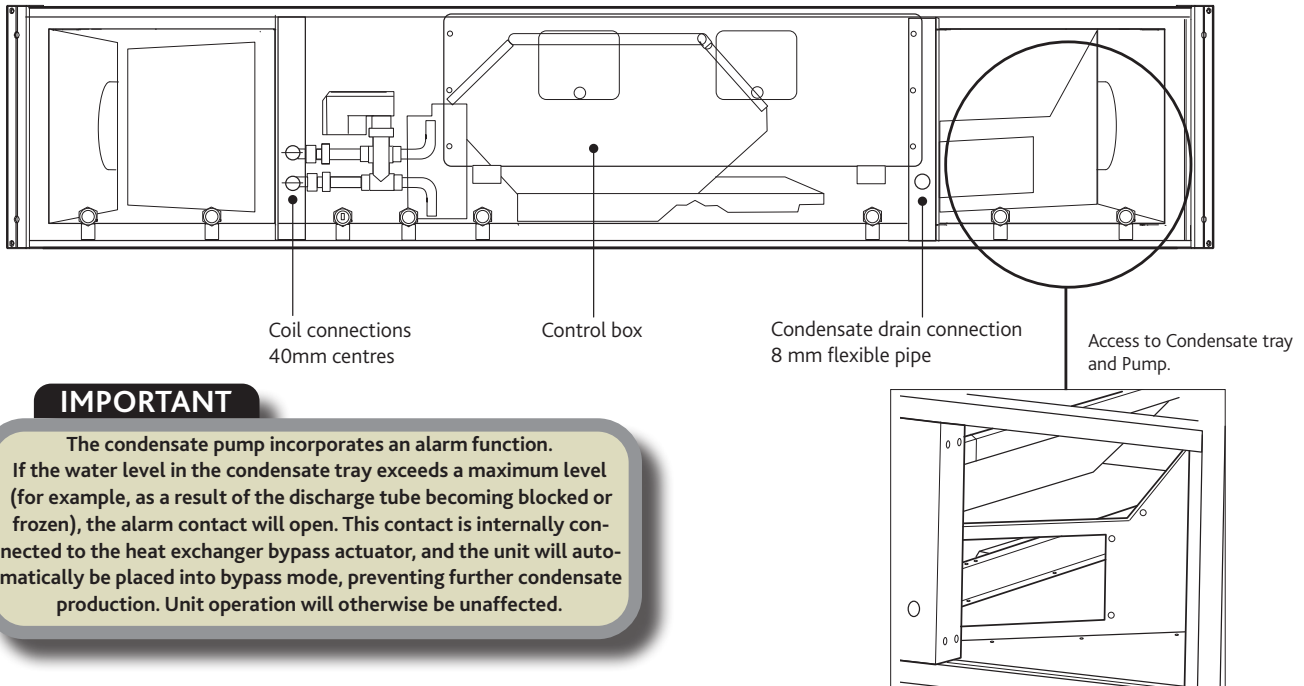

Figure 22. Control side of unit showing coil and condensate connections.



IMPORTANT

The condensate pump incorporates an alarm function. If the water level in the condensate tray exceeds a maximum level (for example, as a result of the discharge tube becoming blocked or frozen), the alarm contact will open. This contact is internally connected to the heat exchanger bypass actuator, and the unit will automatically be placed into bypass mode, preventing further condensate production. Unit operation will otherwise be unaffected.

7.0 Commissioning and Setting To Work

(Note – not all of the components listed here are necessarily included with the equipment supplied).

7.1 Filters

Remove filter access panels (observe and note airflow direction labels), inspect filters for contamination with construction debris, replace as necessary. Replace access panels.

Filter pressure drops will depend on actual flow rate and condition. Observe and record filter pressure drops after performance commissioning. Typically, filter “dirty” condition occurs when the initial filter “clean” readings have been increased by 125Pa.

If filter manometers, pressure switches or indicators have been fitted, they should be set or adjusted to reflect the commissioned system operation.

7.2 Heating Coils LPHW

Observe the Flow and Return connection labels on the unit. Drain and bleed valves are located on the coil. Other valves may be required in the system pipe-work depending on the installation (by others).

Where the wet system is at risk of frost damage, the addition of a proprietary anti-freeze solution to the water is recommended. Note that any frost protection offered by the unit’s integral control system will not operate if the power supply to the unit is interrupted.

Ecosmart frost protection is activated on any Ecosmart unit fitted with LPHW heating, when the outlet air temperature is 4°C or below. The unit reacts by shutting down the fan to prevent a ‘wind chill’ effect reducing the temperature to a point whereby the coil could freeze and burst. The unit will also drive open the LPHW valve to a fully open position to allow full water flow through the coil and the main PCB will close the ‘Heat demand’ contacts. These contacts could be used to send a signal to activate the boiler and/or valve to open to provide heat if not already doing so.

Piped connections should be made to the unit using appropriate techniques, and all pipework must be independently supported. No hot work is permitted within one metre of the unit.

Ensure that installed pipework runs do not prevent or restrict access to the unit at any point.

The completed installation (including the connections within the unit, as these may be disturbed during installation) shall be pressure tested to the project engineer’s specification (**This is a condition of the unit warranty**).

7.3 Fan Sections

Access to the fan section is via lift off panels (see Figure 1 & Figure 22).

For non-Ecosmart units, wiring to the fan motor / unit terminal box should be mechanically protected and in made in accordance with the details on the motor name plate and diagram attached to the unit.

With the unit electrically isolated, rotate the fan impeller / drive manually, checking that it spins freely.

Check all fixings are secure.

Units must not be operated without all access panels in place – damage to equipment or injury to personnel may result. Units must not be operated unless control interlocks are in place – damage to equipment may result.

Test run motor for condition and correct rotation.

Check that the correct current overloads are fitted and that the current being drawn does not exceed the motor nameplate value. Excessive current normally indicates that the ductwork system resistance is different to design.

7.4 Access to fan unit

Access to fan sections on non-control and control side of the unit as well as access to dampers and actuators is shown in Figure 1.

IMPORTANT

Isolation - Before commencing work, make sure that the unit, switched live and Nuair control are electrically isolated from the mains supply.

8.0 Wiring for Ecosmart Control units (ES)

The electrical wiring must be carried out by competent persons, in accordance with good industry practice and should conform to all governing and statutory bodies i.e. IEE, CIBSE, COHSE etc.

Connections

A) Control Connections

Net - the 4 IDC plug-in connectors are provided for the connection of compatible sensors, manual controls and for linking the fans together under a common control. If more than 4 connections are required, the junction box (product code ES-JB) should be used (see data cable installation).

Switch Live (SL) terminal - A signal of 100-230V AC will activate the fan (required at each control).

Note that a signal from an isolating transformer will produce an unpredictable result and is not recommended.

B) Damper Connections

OP - 230V 50Hz 1A max supply to open the damper

CL - 230V 50Hz 1A max supply to close the damper

N - Neutral supply to damper

RET - 230V AC return signal from the damper limit switch indicates the damper has reached its operating position. If the return signal is not present, the fan will wait for 1 minute before starting.

Note: If a damper is not fitted, connect a link wire from OP to RET. This will cancel the delay.

Where units are supplied in modular sections, it will be necessary to install and connect mains wiring between controls and devices such as motorised dampers, it may also be necessary to install and connect mains wiring between sensors and actuators.

Depending on final damper location, extension of the cable looms may be required.

C) Volt Free Relay Contacts

Note that the volt free contacts are not fused. If these are used to power any external equipment, the installer must provide adequate fusing or other protections.

Volt free relay contacts are rated at 5A resistive, 0.5A inductive.

Run Connections - Contacts closed when the fan is running

Fault Connections - No Fault = Contacts are closed

Fault - Contacts are opened

Heat Demand - Contacts closed when heating is selected.

D) Data Cable Installation

A 4-core SELV data cable is used to connect devices.

Do not run data cable in the same conduit as the mains cables and ensure there is a 50mm separation between the data cable and other cables. The maximum cable run between any two devices is 300m when it is installed in accordance with the instructions.

Please note that the total data cable length used in any system must be less than 1000m. Keep the number of cable joints to a minimum to ensure the best data transmission efficiency between devices.

E) Maximum Number of Devices

The maximum number of devices (including fans) that can be connected together via the cable is 32, irrespective of their functions.

F) Other Low Voltage Cables

Follow the basic principle (as d). Keep the cable run as short as possible, less than 50 metres. Use screened cable if cable length is more than 2m.

8.1 Electrical Details

Fans Without Electric Heater		Fans With Electric Heater		
Unit Code	FLC (amps)	Unit Code	Fan FLC (amps)	Heater (amps)
XBC10-H-N**-	3.0	XBC10-H-E**-	3.0	6.3
XBC15-H-N**-	4.0	XBC15-H-E**-	4.0	12.5
XBC25-H-N**-	8.0	XBC25-H-E**-	8.0	18.8
XBC45-H-N**-	6.0	XBC45-H-E**-	6.0	18.8
XBC55-H-N**-	6.0	XBC55-H-E**-	6.0	37.5
XBC65-H-N**-	6.0	XBC65-H-E**-	6.0	37.5

8.2 Wiring Diagram For Units With Ecosmart Control (ES) & LPHW Coil Control

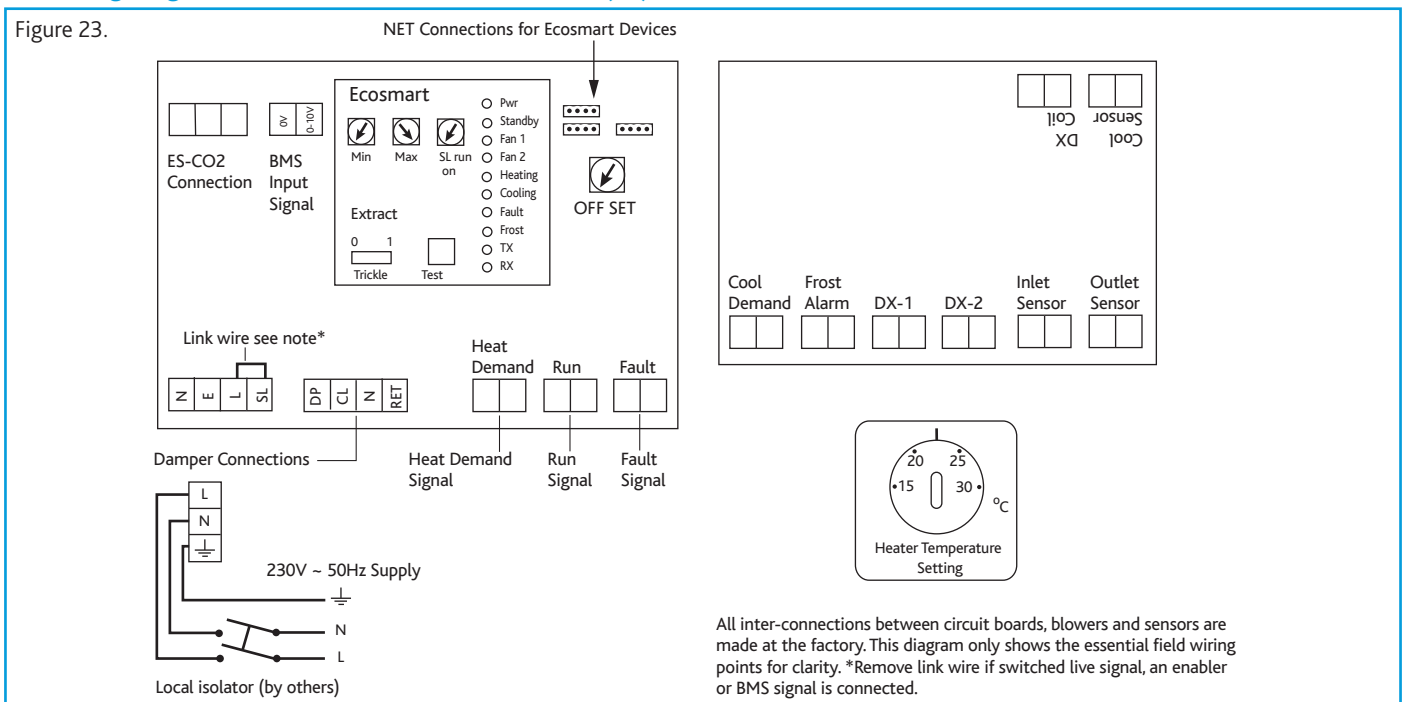

8.3 Wiring Diagram For Units With Ecosmart Control (ES) & Electric Heater

Figure 24.

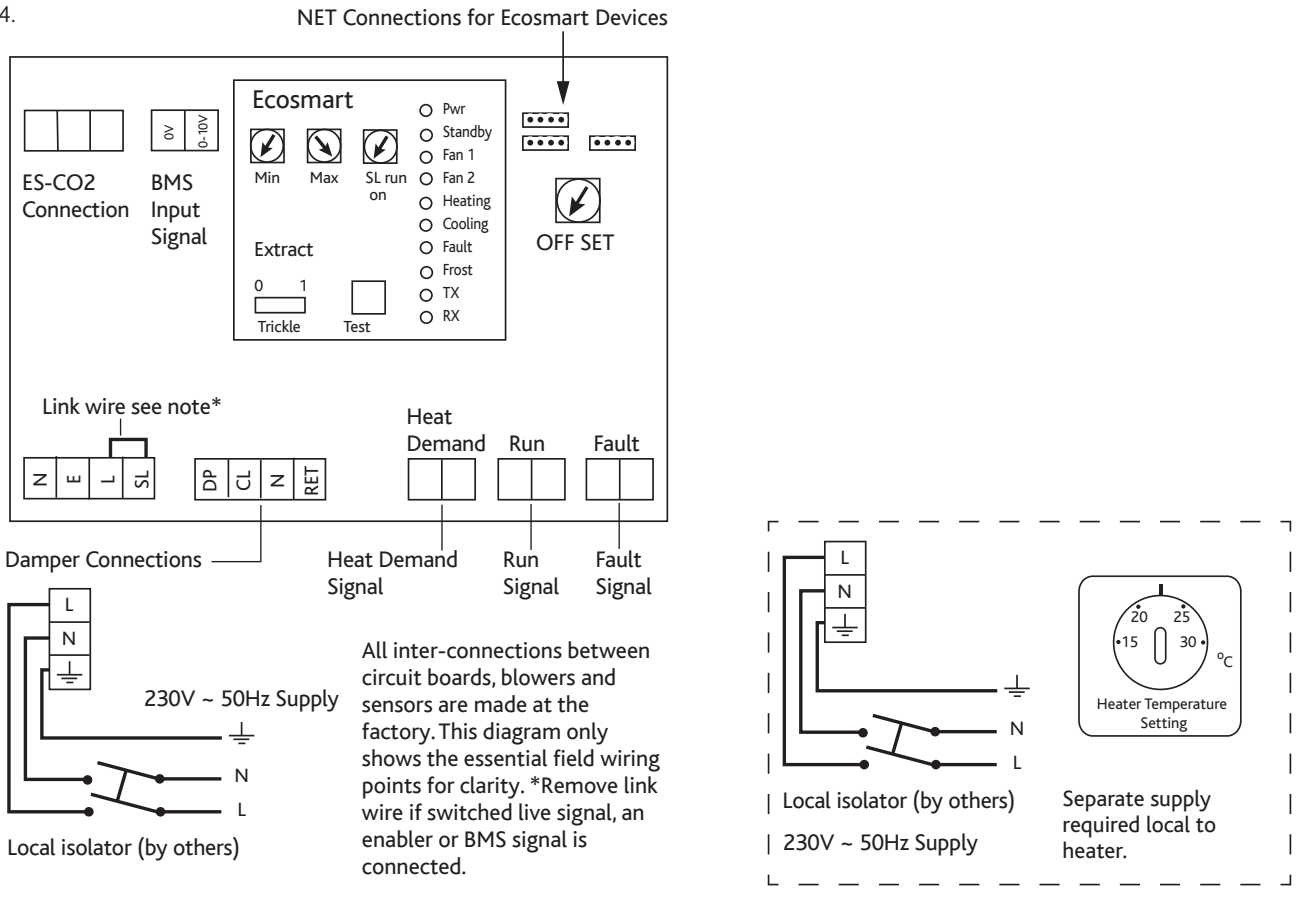

8.4 Wiring Diagram For Units With Ecosmart (ES) Fan Only Control

Figure 25.

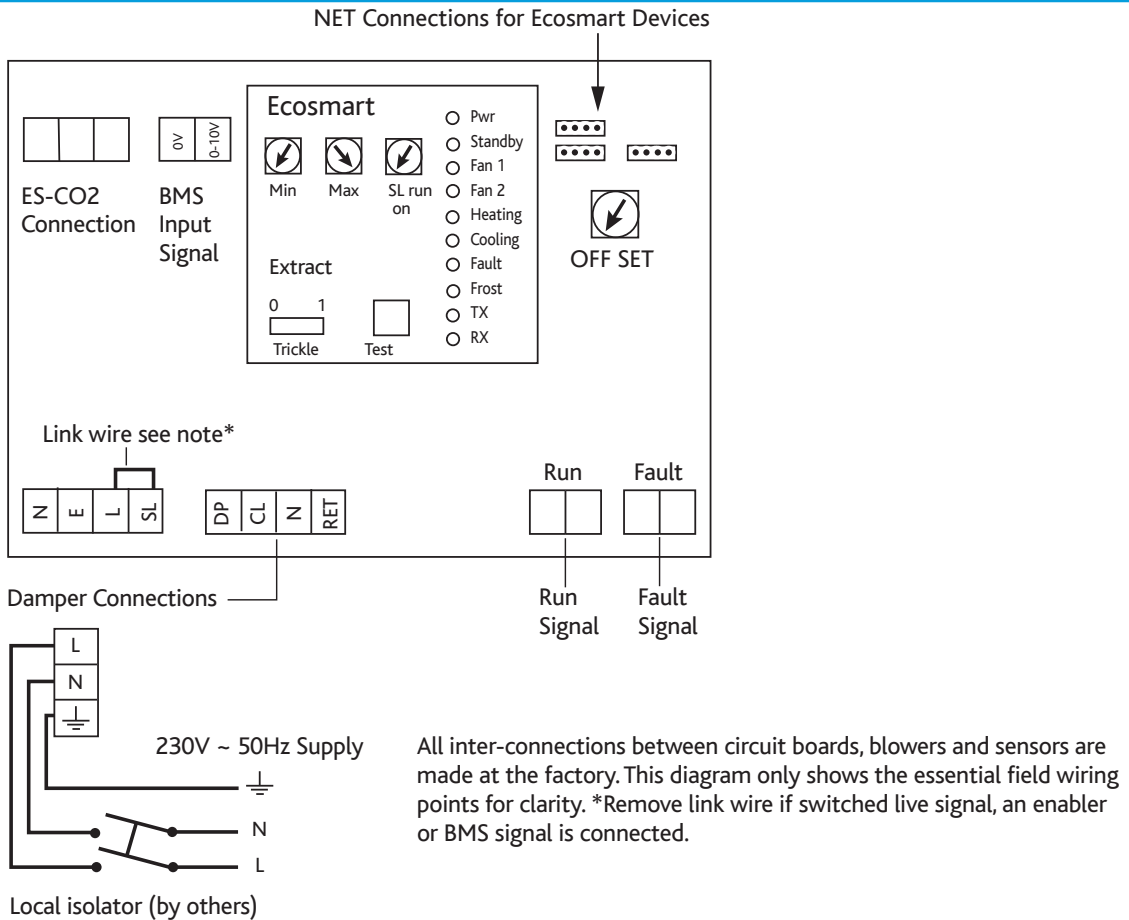

8.5 Setting to Work Using the Test Button Ecosmart Control (Ecosmart Control Only XBC**-H-*ES)

The test button allows the individual blowers within the unit to be checked for its operation. If the fan is running already, press the button once to stop the fan, press again to switch on the fan.

Note that the fan will return to normal operation after 30 seconds.

8.6 Setting Supply and Extract Fan Speed Offset

IMPORTANT

This unit contains two fans and one control. Generally, the two fans operate at similar speeds, but the control includes an "Offset adjustment" for the slower fan (on the main circuit board).

If one of the fans needs to be run slower than the other, move the control extract or supply signal plug into the offset header (Figure 26).

Use the offset ADJ pot (Figure 23, Figure 24 and Figure 25) to turn the speed down.

Maximum turn down is 40%, i.e. reduce the drive signal to the slower fan up to 40%. Note the response of the fan to the drive signal may not be proportional at all signal values.

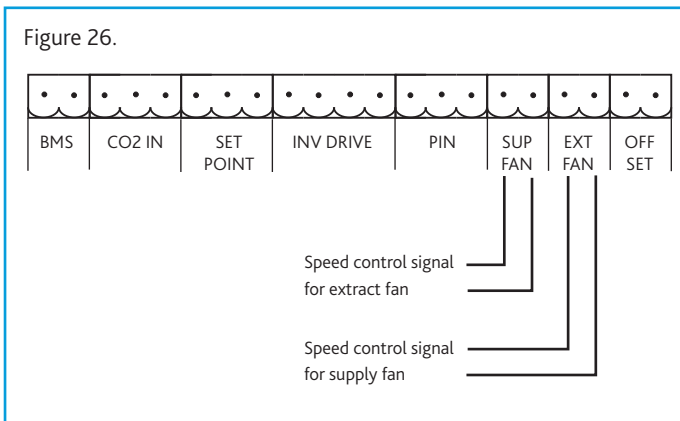

LED Indication

- PWR** GREEN: Power on & OK.
- Standby** LED on when fan is not running.
- Fan 1** GREEN: Fan 1 is running, RED: Fan 1 faulty.
- Fan 2** GREEN: Fan 2 is running, RED: Fan 2 faulty.
- Heating*** GREEN: Heating selected RED: Heating faulty.
- Cooling*** Not applicable. See note.
- Fault** LED on when a fault is present on unit.
- Frost*** Not applicable. See note.
- TX** LED on when the controller is transmitting data.
- RX** LED on when the controller is receiving data.

*** Note that the control panel is common to all the Ecosmart products and will have indicators for functions that are not available in this particular fan. However these indicators will not be illuminated.**

BMS Input Signals

The system's response to a 0-10V DC BMS signal is given in the following table.

Note the BMS signal will override any sensors and user control connected in the system. The voltage tolerance is +/- 125mV and is measured at the fans terminal.

	Ventilation Mode	Cooling Mode*	Heating Mode*
Local Control	0.00	-	-
OFF/ Trickle	0.25	-	-
Speed 1	0.50	0.75	1.00
Speed 2	1.50	1.75	2.00
Speed 3	2.50	2.75	3.00
Speed 4	3.50	3.75	4.00
Speed 5	4.50	4.75	5.00
Speed 6	5.50	5.75	6.00
Speed 7	6.50	6.75	7.00
Speed 8	7.50	7.75	8.00
Speed 9	8.50	8.75	9.00
Speed 10	9.50	9.75	10.00

Settings

Setting the maximum air flow

- Ensure the power supply is switched off and that a link wire is connected from the supply L to the SL terminal. Unplug all items connected to the 'Net' connectors.
- Switch on the power supply.
- Wait for the fan to complete its self-test operation.

Measure the airflow using standard commissioning instruments at a suitable point in the ductwork. If adjustment is required, rotate the pot marked 'MAX' to obtain the desired airflow.

Setting the minimum trickle airflow (20% of maximum air flow)

- Repeat the same procedure as for maximum airflow above but without the link wire between supply L and SL terminal. Ensure the trickle switch is in the 'ON' position. Adjustment must be made on the pot marked 'Min'.
- Note that the minimum setting (20% of maximum air flow) must be below the maximum setting; otherwise minimum setting will be automatically set to be the same as the maximum.

Setting the overrun time

A switched live of 100-230V at terminal SL will activate the fan.

When the switched live signal is removed the fan will overrun for period set by the dial 'SL run on' - adjust the desired overrun time by rotating clockwise.

Setting the trickle ventilation facility

Slide the 'trickle' switch 0 = Off, 1 = On. With 'trickle' on and power to unit, the fan will run at minimum speed until the switch live signal activates it to boost.

Setting the 'air off' temperature

The adjustment knob is located in the control pack and must be set to the desired 'air off' temperature.

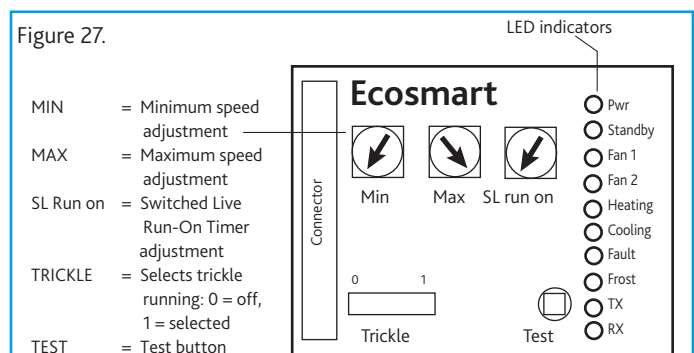

9.0 Wiring diagrams for units supplied without Ecosmart Control (XBC**-H-BC)

IMPORTANT

The Basic (BC) Control units described in this manual are supplied without any controls. It is the installer's responsibility to select and install suitable controller(s) and circuit(s) to produce the desired output from the units while remaining within the units safe performance envelope.

All electric heater control systems must include an over temperature safety device rated at 80°C maximum. The fans should remain running for at least 4 minutes after the electric element is turned off to ensure the unit does not overheat.

The wiring illustrations below are for the fans, bypass damper and electric heater for units without control. All wiring is terminated in junction boxes fitted to the specified side of the unit.

Notes:

- Do not wire the power supply to motor via the motor alarm relay as terminals are only closed after the motor is energized.
- Any heating/cooling coils fitted are supplied without control valve and actuator.
- The alarm relay on condensate may require the use of a contactor if the host equipment supply is switched.

Figure 28. Wiring with for units supplied with Basic control (no Ecosmart Control)

XBC 25 - 65 with Electric Heater

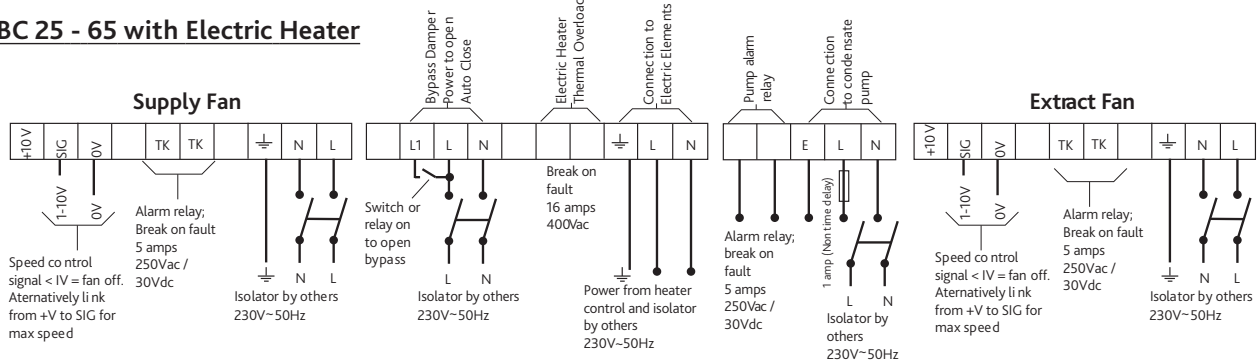

XBC 10 - 15 with Electric Heater

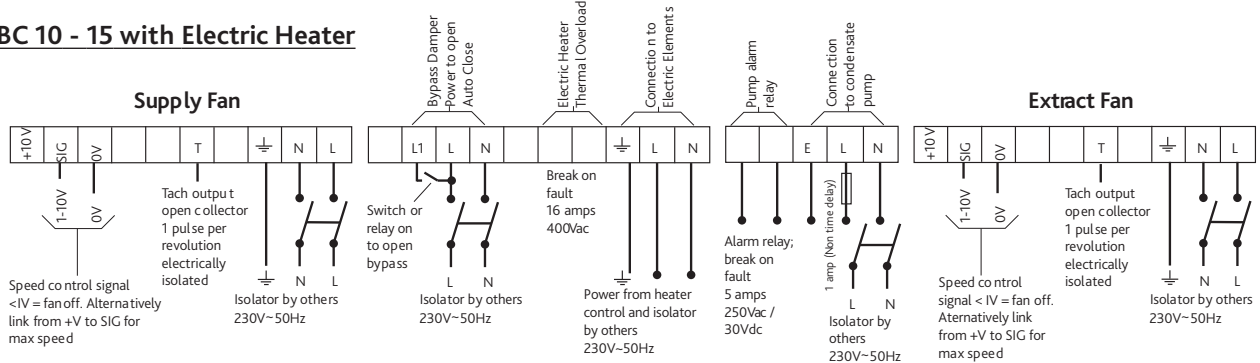

XBC 25 - 65 with LPHW or No Heater

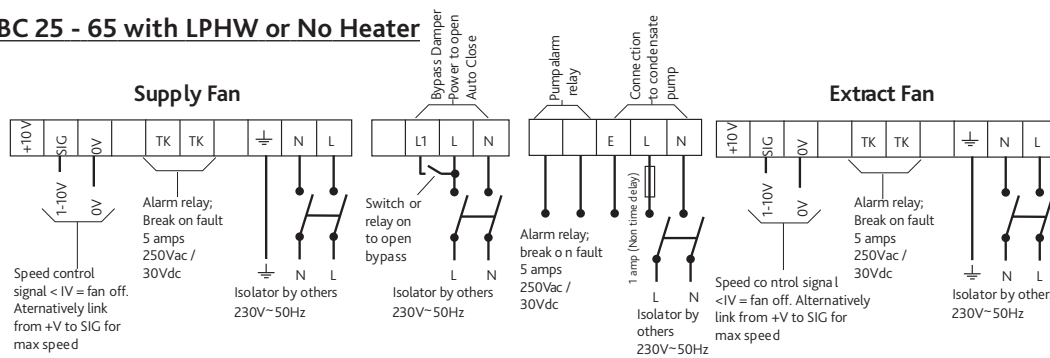

XBC 10 - 15 with LPHW or No Heater

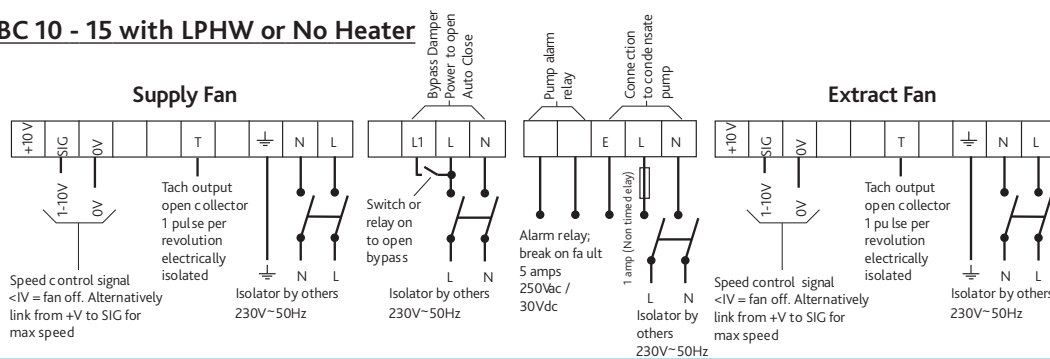

10.0 Maintenance

It is recommended that PPE is always used during the maintenance of Air Handling Equipment – gloves, eye shields and respiratory mask.

IMPORTANT

Isolation - Before commencing work, make sure that the unit and Nuaire control are electrically isolated from the mains supply.

In some Ecosmart units and in some third party controls, variable speed drives (inverters) are used to provide fan speed control. After the fan is isolated, allow at least 5 minutes for the capacitors in the inverter to discharge before commencing any work on the unit.

10.1 Dampers

Regularly check that the damper blades move freely.

10.2 Filters (4 x G4 Fitted as standard)

Disposable filters should be changed when an appropriate pressure drop is achieved.

10.3 Heating Coils

Coils should have their finned surface examined for accumulation of dirt, lint and biological contaminants or similar.

If necessary, wash down affected areas with a mild detergent solution and a soft brush. Care should be taken not to damage the finned surface and any cleaning fluids should be rinsed away with water. A compressed air line may be used to blow out any solids between fins. Do not probe the coil fin block with metal objects as damage may cause leaks.

Drain lines should be checked to ensure that they are unobstructed and free draining.

Drain pans should be flushed out periodically to remove contamination.

Note: The unit application may require particular attention to this item – Check with Building Management personnel for details.

10.4 Counterflow Plate Heat Exchanger

The heat exchanger block is normally protected from dust and contamination by upstream pre-filters. It is possible to clean the unit with compressed air in the case of dust deposits or by spraying with a mild detergent solution for grease deposits. Solvents, strong alkaline, acidic or any products that may be aggressive to aluminium should not be used. Do not use cleaning water over a temperature of 50°C.

Drain lines should be checked to ensure that they are unobstructed and free draining. Traps should be checked that they are fully primed and functioning.

Drain pans should be flushed out periodically to remove contamination, and chemical treatments may be used to provide protection between service visits.

Note: The unit application may require particular attention to this item – Check with Building Management personnel for details.

10.5 Fans and Motors

Fan bearings should be manually checked at regular intervals for condition. Standard fan bearings are supplied as 'sealed for life' and have an anticipated life of 40,000 hours.

Motors have an enclosed bearing housing and are pre-greased for life. Check all fixings are secure.

10.6 General

Inspect all internal and external surfaces to check for corrosion or peeling of painted surfaces.

Thoroughly clean affected areas with a wire brush, apply a coat of zinc rich primer or similar, and re-touch with suitable finishing paint. Ensure tightness of all nuts, bolts, and fixings.

Check all components for general condition.

11.0 Service Schedule

Typical—will depend on site conditions

	6 MONTHS	12 MONTHS
G4 FILTERS	✓ or	✓
F7 FILTERS	✓	
DAMPERS		✓
DAMPER ACTUATORS		✓
VENT WATER COILS		✓
COIL FINNED SURFACES		✓
CHECK DRAIN LINES + DRIP TRAY	✓	✓
CHECK DRAIN PANS	Building Schedule?	✓
NUTS, BOLTS, FIXINGS SECURE		✓
FAN BEARINGS	✓	
ELECTRIC HEATERS		✓
ELECTRICAL WIRING		✓
FAN IMPELLER	✓	
GENERAL		✓

12.0 Warranty

5 year warranty on Ecosmart models for peace of mind. Basic control models have a 2 year warranty. The warranty starts from the day of delivery and includes parts and labour for the first year. The remaining period covers replacement parts only.

This warranty is void if the equipment is modified without authorisation, is incorrectly applied, disassembled misused or not installed commissioned and maintained in accordance with the details contained in this manual and general good practice.

The product warranty applies to the UK mainland and in accordance with Clause 14 of our Conditions of Sale. Customers purchasing from outside of the UK should contact Nuaire International Sales office for further details.

13.0 After Sales Enquiries

For technical assistance or further product information, including spare parts and replacement components, please contact the After Sales Department.

Telephone 02920 858 400
aftersales@nuaire.co.uk

DECLARATION OF INCORPORATION AND INFORMATION FOR SAFE INSTALLATION, OPERATION AND MAINTENANCE

We declare that the machinery named below is intended to be assembled with other components to constitute a system of machinery. All parts except for moving parts requiring the correct installation of safety guards comply with the essential requirements of the Machinery Directive. The machinery shall not be put into service until the system has been declared to be in conformity with the provisions of the EC Machinery Directive.

Signature of manufacture representatives:

Name:		Position:	Date:
1) C. Biggs		Technical Director	13. 05. 16.
2) A. Jones		Manufacturing Director	13. 05. 16.

Designation of machinery: XBOXER XBC Ecosmart Classic (ES) and Basic Control (BC) models

Machinery Types: Supply & Extract fans with Heat Recovery

Relevant EC Council Directives: 2006/42/EC (Machinery Directive)

Applied Harmonised Standards: BS EN ISO 12100, BS EN ISO 13857 EN60204-1, BS EN ISO 9001

Applied National Standards: BS848 Parts 1, 2.2 and 5

Note: All standards used were current and valid at the date of signature.

INFORMATION FOR SAFE INSTALLATION, OPERATION AND MAINTENANCE OF NUAIRE VENTILATION EQUIPMENT

To comply with EC Council Directives 2006/42/EC Machinery Directive and 2014/30/EU (EMC).
To be read in conjunction with the relevant product documentation (see 2.1)

1.0 GENERAL

1.1 The equipment referred to in this Declaration of Incorporation is supplied by Nuair to be assembled into a ventilation system which may or may not include additional components. The entire system must be considered for safety purposes and it is the responsibility of the installer to ensure that all of the equipment is installed in compliance with the manufacturers recommendations and with due regard to current legislation and codes of practice.

2.0 INFORMATION SUPPLIED WITH THE EQUIPMENT

2.1 Each item of equipment is supplied with a set of documentation which provides the information required for the safe installation and maintenance of the equipment. This may be in the form of a Data sheet and/or Installation and Maintenance instruction.

2.2 Each unit has a rating plate attached to its outer casing. The rating plate provides essential data relating to the equipment such as serial number, unit code and electrical data. Any further data that may be required will be found in the documentation.

2.3 If any item is unclear or more information is required, contact Nuair.

2.3 Where warning labels or notices are attached to the unit the instructions given must be adhered to.

3.0 TRANSPORTATION, HANDLING AND STORAGE

3.1 Care must be taken at all times to prevent damage to the equipment. Note that shock to the unit may result in the balance of the impeller being affected.

3.2 When handling the equipment, care should be taken with corners and edges and that the weight distribution within the unit is considered. Lifting gear such as slings or ropes must be arranged so as not to bear on the casing.

3.3 Equipment stored on site prior to installation should be protected from the weather and steps taken to prevent ingress of contaminants.

4.0 OPERATIONAL LIMITS

4.1 It is important that the specified operational limits for the equipment are adhered to e.g. operational air temperature, air borne contaminants and unit orientation.

4.2 Where installation accessories are supplied with the specified equipment e.g. wall mounting brackets. They are to be used to support the equipment only. Other system components must have separate provision for support.

4.3 Flanges and connection spigots are provided for the purpose of joining to duct work systems. They must not be used to support the ductwork.

4.4 **Local Environment - Humidity.** Ambient humidity (the humidity at the unit's installed location) shall be within the range: 10 to 95% (for controls, non-condensing). Air humidity (the humidity of the air passing through the unit) shall be within the range: 10 to 95% (for controls, non-condensing).

5.0 INSTALLATION REQUIREMENTS

In addition to the particular requirements given for the individual product, the following general requirements should be noted.

5.1 Where access to any part of equipment which moves, or can become electrically live are not prevented by the equipment panels or by fixed installation detail (e.g. ducting), then guarding to the appropriate standard must be fitted.

5.2 The electrical installation of the equipment must comply with the requirements of the relevant local electrical safety regulations.

5.3 For EMC all control and sensor cables should not be placed within 50mm or on the same metal cable tray as 230V switched live, lighting or power cables and any cables not intended for use with this product.

6.0 COMMISSIONING REQUIREMENTS

6.1 General pre-commissioning checks relevant to safe operation consist of the following:
Ensure that no foreign bodies are present within the fan or casing.
Check electrical safety e.g. Insulation and earthing.
Check guarding of system.
Check operation of Isolators/Controls.
Check fastenings for security.

6.2 Other commissioning requirements are given in the relevant product documentation.

7.0 OPERATIONAL REQUIREMENTS

7.1 Equipment access panels must be in place at all times during operation of the unit, and must be secured with the original fastenings.

7.2 If failure of the equipment occurs or is suspected then it should be taken out of service until a competent person can effect repair or examination. (Note that certain ranges of equipment are designed to detect and compensate for fan failure).

8.0 MAINTENANCE REQUIREMENTS

8.1 Specific maintenance requirements are given in the relevant product documentation.

8.2 It is important that the correct tools are used for the various tasks required.

8.3 If the access panels are to be removed for any reason the electrical supply to the unit must be isolated.

8.4 A minimum period of two minutes should be allowed after electrical disconnection before access panels are removed. This will allow the impeller to come to rest.

NB: Care should still be taken however since airflow generated at some other point in the system can cause the impeller to "windmill" even when power is not present.

8.5 Care should be taken when removing and storing access panels in windy conditions.