

AVT/AVTCP

Indoor Use Twin Fans with Ecosmart Control Installation Manual

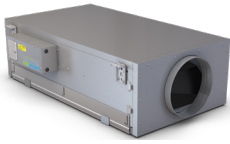

1.0 SAFETY INFORMATION

- The provision of the electrical supply and the connection of the unit to the mains must be carried out by a qualified electrician.
- Isolate from power supply before removing any covers. During installation / maintenance ensure all covers are fitted before switching on the mains supply.
- All-pole disconnection from the mains as shown in the wiring diagram must be incorporated within the fixed wiring and shall have a minimum contact separation of 3mm in accordance with latest edition of the wiring regulations.
- This unit must be earthed.
- Ducting must be securely fixed with screws to the spigot to prevent access to live parts. Duct runs terminating close to the fan must be adequately protected by suitable guards.
- Precautions must be taken to avoid the back-flow of gases into the room from the open flue of gas or other fuel-burning appliances.
- This appliance should not be used by children or persons with reduced physical, sensory or mental capabilities or lack of experience and knowledge, unless they have been given supervision or instruction concerning the safe use of the appliance by a person responsible for their safety. Children shall not play with the appliance. Cleaning and user maintenance shall not be carried out by children.

1.1 Symbols



GENERAL WARNING

Signifies a general warning regarding hazard specified by supplementary information.



ELECTRIC SHOCK

This unit must be completely electrically isolated before any panels are removed. Check mains supply and control connections.



ROTATING PARTS

This unit contains fast moving rotational parts which may start automatically. It is the sole responsibility of the installer to adequately guard these components.



REFER TO INSTRUCTION MANUAL

Read and understand the installation and maintenance manual before installing, operating or maintaining this product.

1.2 Important Information

This manual contains important information on the safe and appropriate assembly, transport, commissioning, operation, maintenance, disassembly and simple troubleshooting of the product.

While the product has been manufactured according to the accepted rules of current technology, there is still a danger of personal injury or damage to equipment if the following general safety instructions and the warnings contained in these instructions are not complied with.

- Read these instructions completely and thoroughly before working with the product.
- Keep these instructions in a location where they are accessible to all users at all times.
- Always include the operating instructions when you pass the product on to third parties.

1.3 Personal Protective Equipment

The following minimum Personal Protective Equipment (PPE) is recommended when interacting with Nuaire product:

- **Protective Steel Toed Shoes** - when handling heavy objects.
- **Full Finger Gloves (Marigold PU800 or equivalent)** - when handling sheet metal components.
- **Semi Fingerless Gloves (Marigold PU3000 3DO or equivalent)** - when conducting light work on the unit requiring tactile dexterity.
- **Safety Glasses** - when conducting any cleaning/cutting operation or exchanging filters.
- **Reusable Half Mask Respirators** - when replacing filters which have been in contact with normal room or environmental air.

Nuaire would always recommend a site specific risk assessment by a competent person to determine if any additional PPE is required.

2.0 INTRODUCTION

Units are rectangular in section and have circular rigid spigots at each end. Four matching mounting feet are supplied with the unit. The unit shall be double skinned with 35mm infill panels and shall be manufactured from heavy gauge, corrosion resistant Aluzinc steel, internally lined with acoustic material. Fully detachable panels for maintenance/service and manometer test points. The fan should be with an 'inline assembly', positioned in series for optimum performance.

Units 1 - 6 incorporate a full size access panel fitted to the bottom face which is fully detachable for inspection purposes. The underside access panel can be slid in either direction with-out removal, if required (Section 4.9.1).

Units 7 - 9 incorporate a split access panel fitted to the bottom face which is fully detachable for inspection purposes. Each split access panel can be moved and opened individually and slid in either direction without removal, if required (Section 4.9.2).

2.1 Code Description:

1	2	3	4
AV	T	CP	1

- 1. Range: AV = Aire-Volve
- 2. Fan Type: T = Twin Fan
- 3. Constant Pressure: CP = Constant Pressure
Controls No Affix = No Constant Pressure
- 4. Unit Size: 1, 2, 3, 4, 4L, 5, 6, 7, 8, 9

1 General View Of Standard AVT(1-6) Unit Configuration

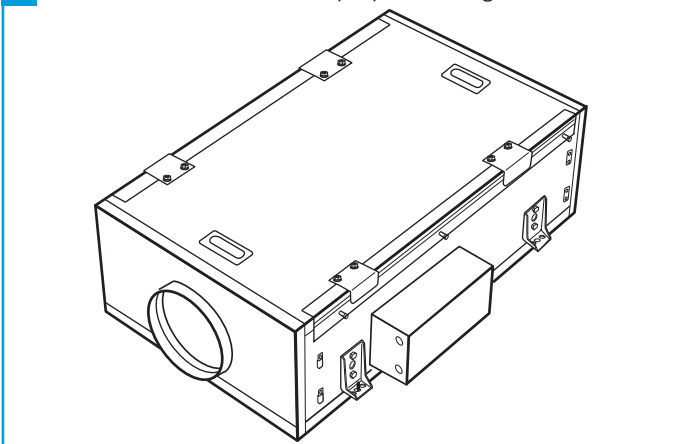

3.0 HANDLING

Upon receipt of the equipment, an inspection should be made. Before commencement of lifting, ensure that normal equipment safety checks have been carried out.

A unit / module should be removed from the vehicle using a fork lift or crane. Always handle with care to avoid damage and distortion, and where lifting slings are employed use spreaders to ensure slings do not come into contact with the unit case, or control pack. Correctly position slings to avoid twisting of the unit case and observe the centre of gravity before the final lift is made. **The weight of the unit is available on the unit rating plate.**

Dependent on model and size, units may be supplied in single or multi-modular sections. Handle each section individually do not stack for lifting or storage.

4.0 MECHANICAL INSTALLATION

Installation must be completed by competent persons, in accordance with good industry practice and should conform to all governing and statutory bodies i.e. IEE, CIBSE, etc.

The units are supplied for installation into In-line ductwork (internal) applications only. All ductwork connections must be airtight to prevent loss of performance.

The unit has an external case side mounted control module / terminal box and is supplied ready for connection into the electrical supply. The control is mounted on the side of the unit as standard but its position can be changed to the other side of the unit if required, fixings by others (Section 4.10).

The method of mounting used is the responsibility of the installer. **The units can be mounted in any of the below attitudes** enabling alternative control positions.

Once assembled, units should always be positioned with sufficient free space adjacent to the unit to allow for access panel(s) to extend forward for future inspection, maintenance, component service, repair and replacement. **The access panel(s) require opening clearance to operate.**

4.1 Umbilical Cord Kits (AVT1-8 Only)

As an option, an umbilical cord can be purchased for remote mounting up to 1m away (Figure 4). **1m Umbilical Cord Kit Code: AVT-CK (single phase units only).**

4.2 Surface Mounted Units

Utilising four matching anti-vibration (AV) mounting feet (Figure 1). **AV mounts isolate the fan only, silencers / back draught dampers and other "significant mass" accessories should form part of the fixed ductwork after the flexible connection.**

4.3 Units Suspended With Drop Rods

From the ceiling or in the ceiling void using four AV mounting feet supplied, with access panel positioned for underside access (Figure 2 & 3).

2 Typical AVT (1-6) Unit Ceiling Void Installation

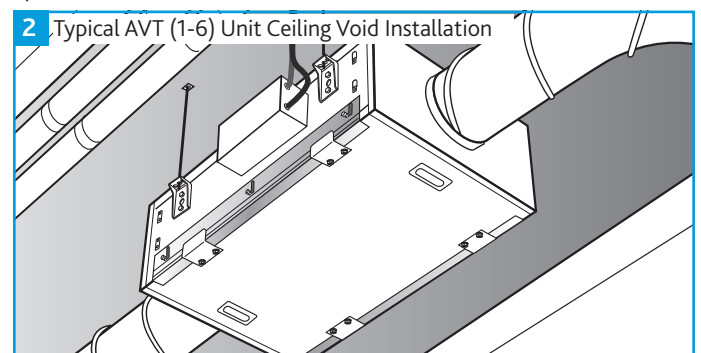

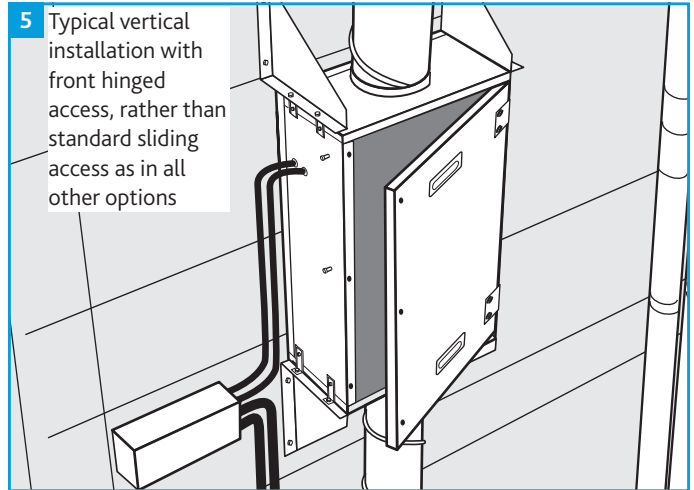
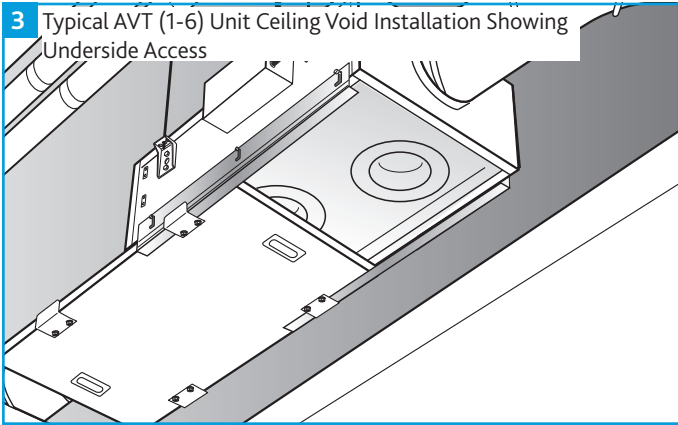

4.4 Vertically Wall Mounted Units

Utilising the Aire-Volve Vertical Hanging Bracket kit that includes wall hanging brackets and hinges (Figures 4 and 5). The unit case has captive M8 nuts which can be used after removing the M8 'plugging' screws. Units should always be positioned with sufficient space to allow the access panel to extend forward. **Only suitable for units mounted indoors.**

Aire-Volve Unit Size	Aire-Volve Vertical Hanging Bracket Kit
1	AVT1-VK
2	AVT2-VK
3	AVT3-VK
4	AVT4-VK
4L	AVT4L-VK
5	AVT5-VK
6	AVT6-VK

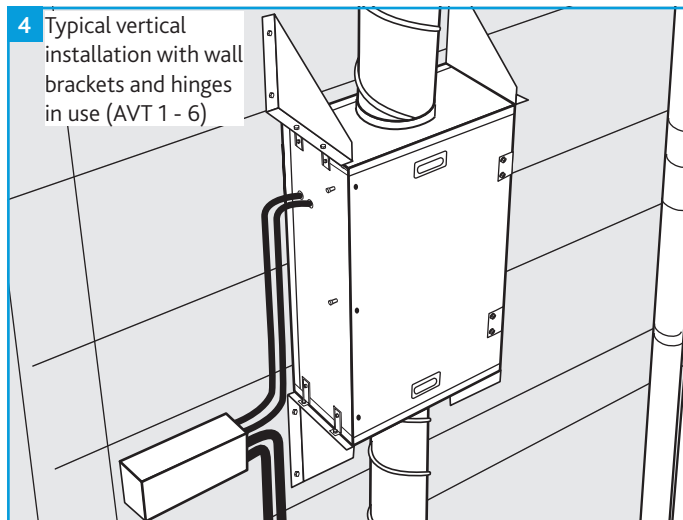

4.5 Anti-Vibration (AV) Mounts

AV mounts should not be fitted to a fan/silencer assembly unless there are flexible connectors fitted between the assembly and associated duct work. AV mounts should be installed with the matched mounting feet and positioned such that they carry an equal proportion of the assembly weight. This is particularly important where fans and silencers are installed on suspension rods. Suspension rods and fixing screws are not supplied.

Resilient rubber anti-vibration mounting kits (NAV) are available, the correct selection and type employed will depend on the accurate calculation of the weight of the assembly to be supported.

The large round washers included with the NAV(2-5) are for fitting above or below the resilient mounting as required to safeguard the installation against break-up of, or damage to, a mounting. In the event of a resilient mounting failure, the washer will support the weight of the unit. Fans using size NAV 6 upwards require supporting steelwork to be designed (by others) for suspended applications.

AV mounts must only be subjected to compressional forces and MUST NOT be used in a configuration that places these parts under tension or shear force.

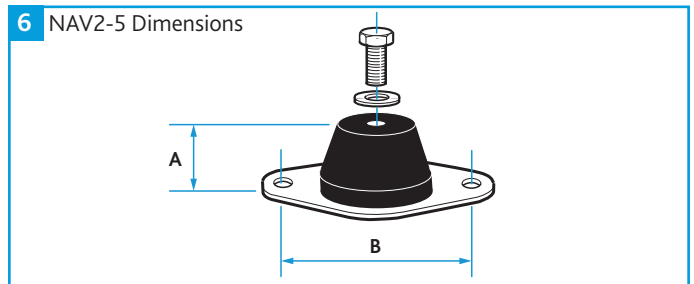

Anti-Vibration Mounting Kit	A (mm)	B (mm)	Max. Supporting Weight (kg)
NAV2	40	75	80
NAV3	40	75	180
NAV4	40	75	260
NAV5	40	75	130

7 Correctly Installed NAV(2-5) - Suspended Application

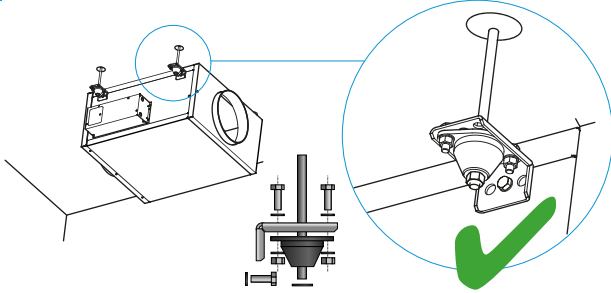

8 Correctly Installed NAV(2-5) - Suspended Application

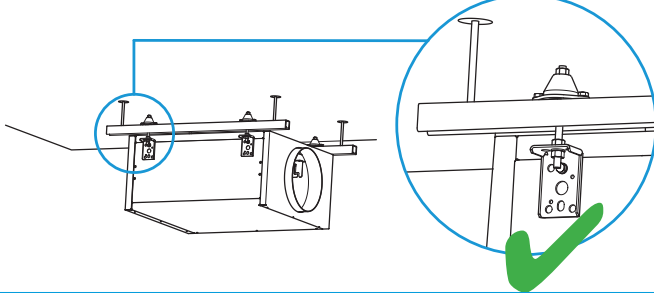

9 Incorrectly Installed NAV(2-5) - Suspended Application

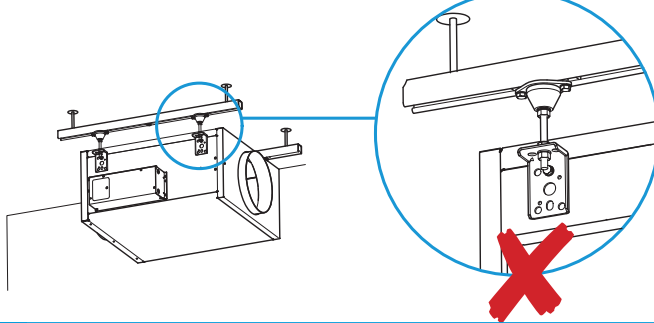

10 Correctly Installed NAV(2-5) - Floor Mounted Application

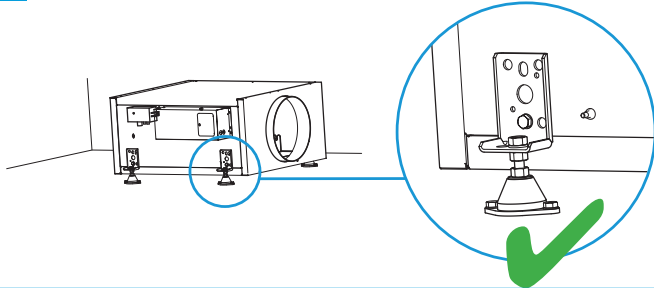

11 Unit Dimensions

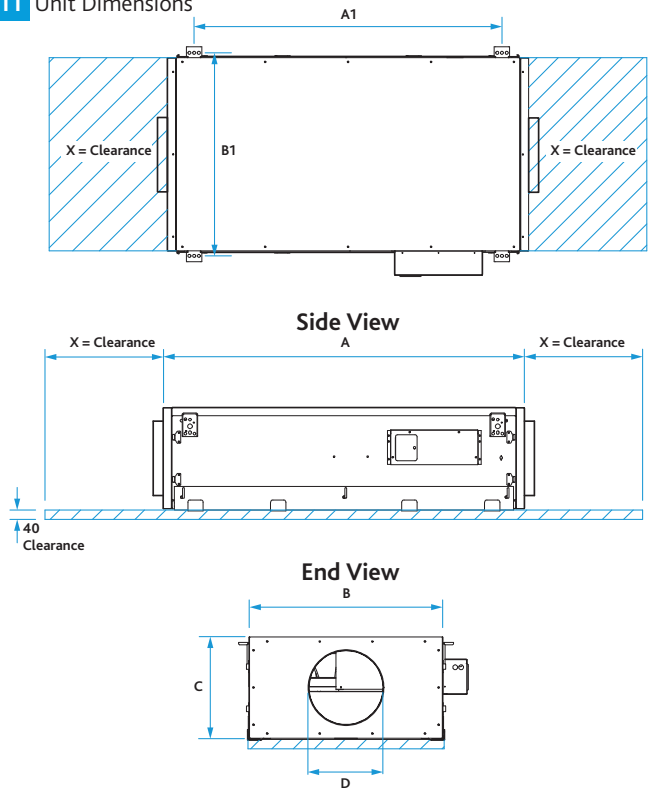

4.6.2 Matched AVT Silencers

Matched silencers with double walled Aluzinc construction and 35mm infill acoustic lining provides the best acoustic solution.

Easy fit matching silencers with simple integral brackets can be easily incorporated into existing drop rod systems helping to reduce install time on site.

12 AVS Matched Silencer Dimensions

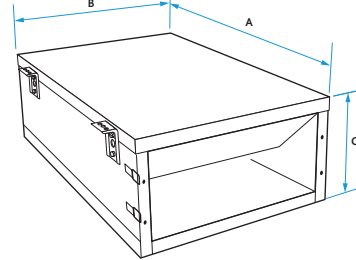

Unit Code	Silencer Code	Size	A	B	C	Weight (kg)
AVT1	AVT1-MSM	Mini	500	544	260	27
	AVT1-MSS	Standard	1000	544	260	32
	AVT1-MSL	Large	1500	544	260	45
AVT2	AVT2-MSM	Mini	500	544	286	27
	AVT2-MSS	Standard	1000	544	286	32
	AVT2-MSL	Large	1500	544	286	45
AVT3	AVT3-MSM	Mini	500	681	332	30
	AVT3-MSS	Standard	1000	681	332	39
	AVT3-MSL	Large	1500	681	332	56
AVT4	AVT4-MSM	Mini	500	681	374	34
	AVT4-MSS	Standard	1000	681	374	39
	AVT4-MSL	Large	1500	681	374	56
AVT4L	AVT4L-MSM	Mini	500	827	401	34
	AVT4L-MSS	Standard	1000	827	401	42
	AVT4L-MSL	Large	1500	827	401	61

4.6 Dimensions (mm) & Weights (kg)

4.6.1 AVT Units

Unit Code	A [†]	A1 (Bracket Centre Points)	B [‡]	B1 (Bracket Centre Points)	C	D	X	Weight (kg)
AVT1	931	701	544	576	250	200	430	46
AVT2	968	738	544	576	285	200	430	48
AVT3	1186	955	681	713	334	250	555	67
AVT4	1229	999	681	713	376	315	655	68
AVT4L	1531	1262	827	860	401	315	880	99
AVT5	1531	1301	827	860	433	315	880	102
AVT6	1729	1504	921	953	545	400	830	153
AVT7	1892	1666	1019	1050	575	400	655	179
AVT8	2238	2007	1244	1275	615	500	635	267
AVT9	2238	2007	1244	1275	615	500	635	244

[†] Add 100mm for unit + spigot length.

[‡] Add 104mm for unit + control width.

Unit Code	Silencer Code	Size	A	B	C	Weight (kg)
AVT5	AVT5-MSM	Mini	500	827	781	43
	AVT5-MSS	Standard	1000	827	781	44
	AVT5-MSL	Large	1500	827	781	65
AVT6	AVT6-MSM	Mini	500	921	552	43
	AVT6-MSS	Standard	1000	921	552	65
	AVT6-MSL	Large	1500	921	552	89
AVT7	AVT7-MSM	Mini	500	1019	653	43
	AVT7-MSS	Standard	1000	1019	653	71
	AVT7-MSL	Large	1500	1019	653	98
AVT8	AVT8-MSM	Mini	500	1244	753	51
	AVT8-MSS	Standard	1000	1244	753	83
	AVT8-MSL	Large	1500	1244	753	114
AVT9	AVT9-MSM	Mini	500	1244	774	92
	AVT9-MSS	Standard	1000	1244	774	116
	AVT9-MSL	Large	1500	1244	774	125

4.7 Silencer Installation

To change orientation of attenuator pod just turn silencer over before fitting. Use fixing brackets as shown below. **Ensure that the attenuator pods are in the correct orientation as shown in Figure 16.**

4.7.1 All Unit Sizes Except AVT4L

Remove spigot panels from each end of the main unit and relocate them to the open silencer ends. The coupling system located on the sides of the silencers and AVT unit simply clips together with additional alignment bolts (ensure alignment bolts are correctly located).

4.7.2 AVT4L Units Only

Ensure fixing brackets halves are correctly aligned and assemble using M8 Cap head bolt and nut supplied with bracket. Once located, tighten bolts ensuring seal between silencer and seal is achieved.

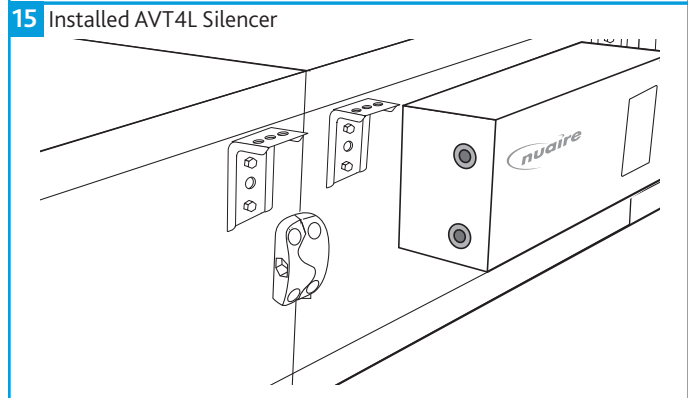
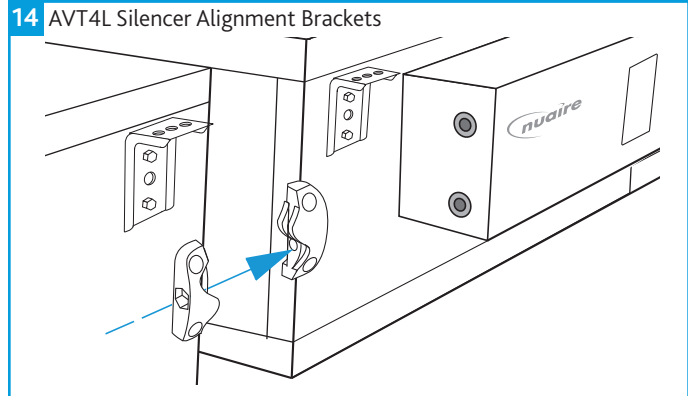
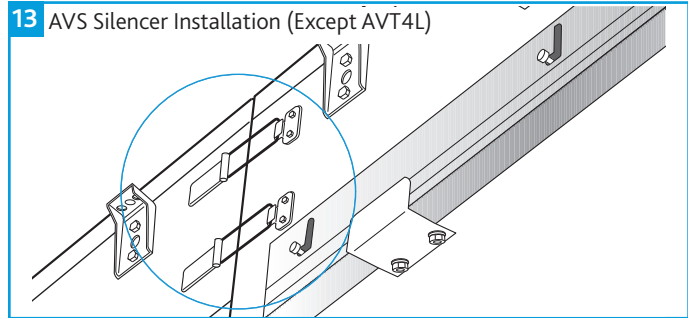

16 Typical Side Section View Of Outlet Silencer, Floor Mounted Unit And Inlet Silencer

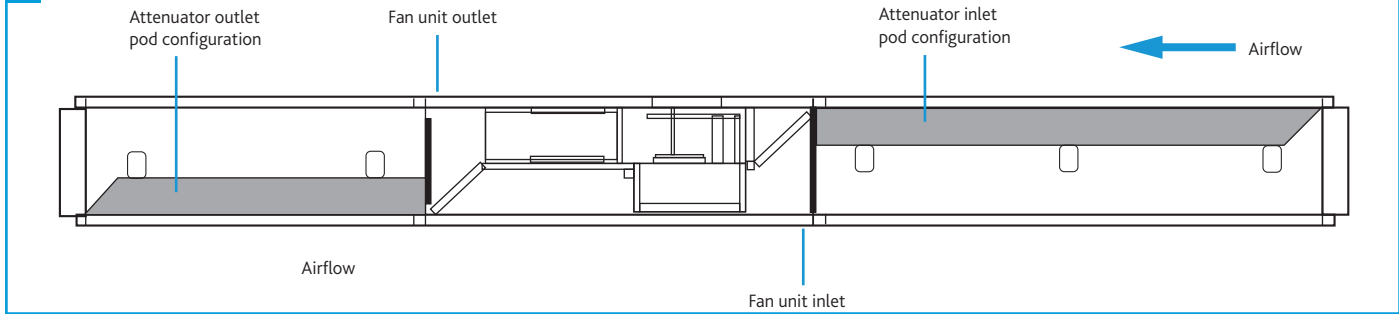

4.8 Constant Pressure Units (AVTCP)

Ecosmart constant pressure extract fans are supplied to control the static pressure at the fan inlet. This set up is suitable for the majority of applications. However, when ancillaries with high pressure losses

are fitted to the fan's inlet side, the low pressure tapping needs to be moved from the fan chamber to a location upstream of the ancillaries (Figure 17). **Failure to do this will result in excessive pressure being applied to the dampers at the rooms when the system is running in trickle mode.**

17 Constant Pressure Arrangement

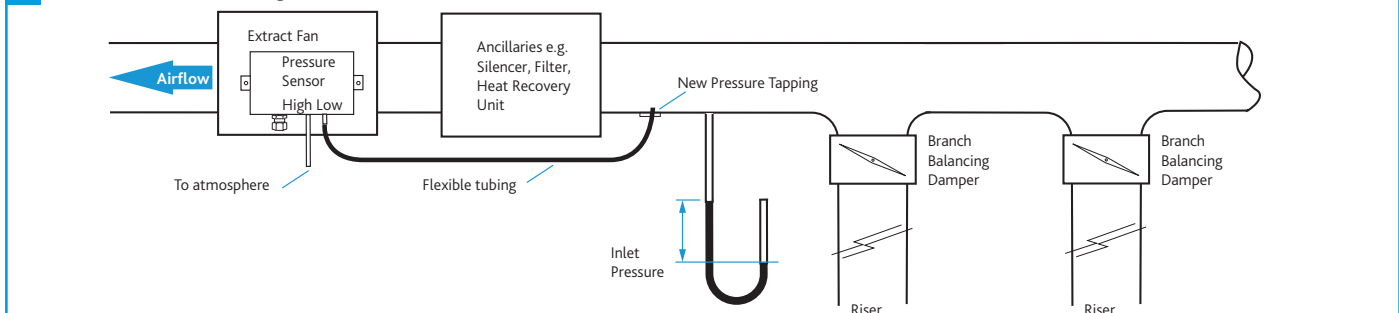

4.9 Unit Access

4.9.1 AVT 1-6 Access

1. Release 6 base fixings, 3 each end of each access panel (note captive fixings).
2. Release 6 lower end panel fixings, 3 each end of the unit.
3. Lower the extrusion containing the access panel (on each side of the unit) so the 3 extrusion fixings move to the top of the 3 'L' cut-out shapes in the sides of the extrusions. When completed the extrusions / access panel will drop down by the depth of the 'L' cut-out shapes enabling the access panel to be slid open.
4. Slide access panel along the inside of the extrusions until the plunger locks into the base of the extrusion to gain access to the blowers.
5. To close the access panel, ensure retaining brackets are aligned then push plungers back into the extrusion base to release access panel, before sliding back to its original aligned position.
6. Lift the extrusion (on each side of the unit) containing the access panel to its original position so that the 3 extrusion fixings move back to the bottom of the 'L' cut-out shapes as shown and lock.
7. To complete closure of the access panel and make secure, re-tighten 6 lower end panel fixings, 3 each end of the unit and the 6 base fixings, 3 each end of the access panel.

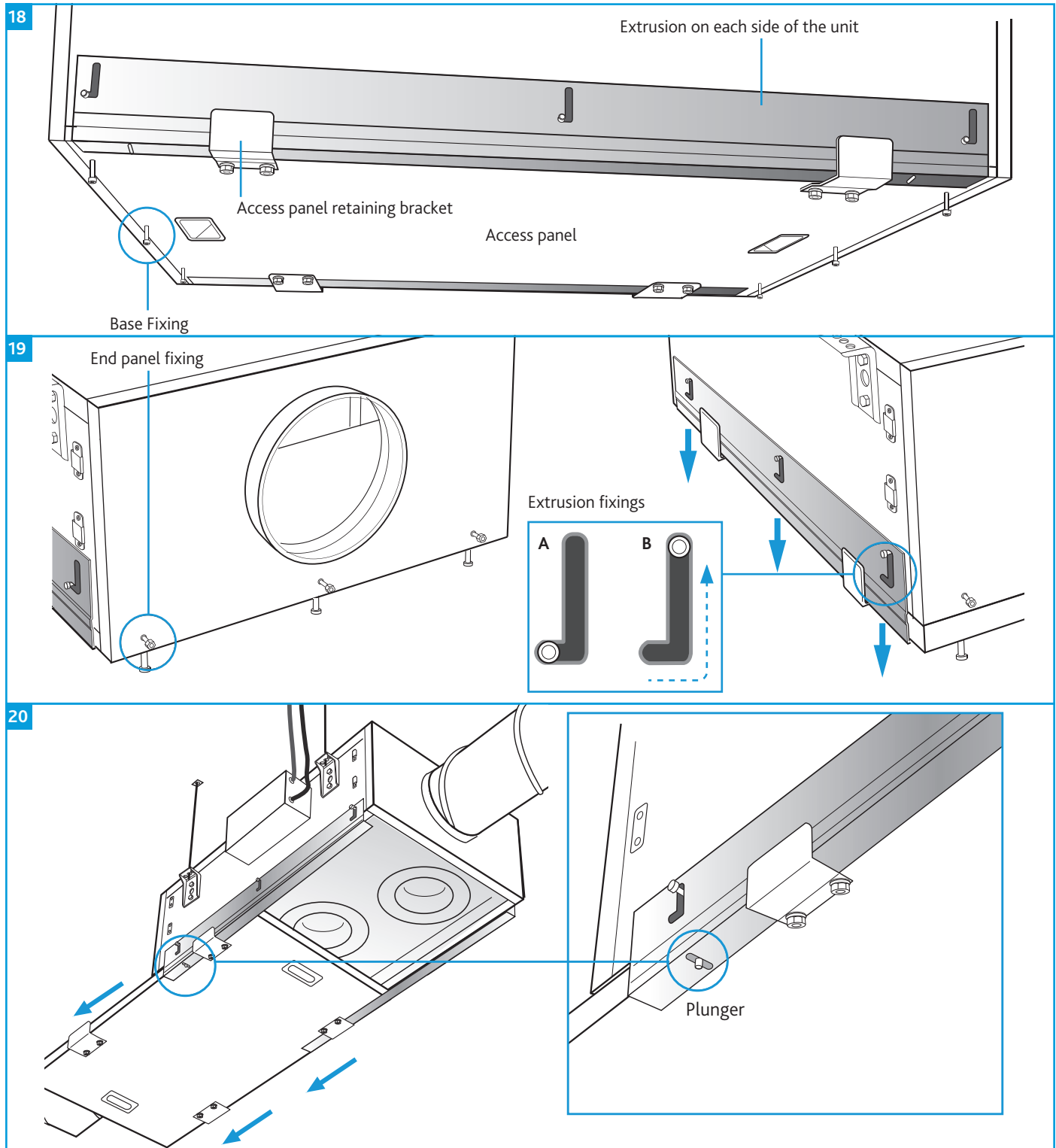

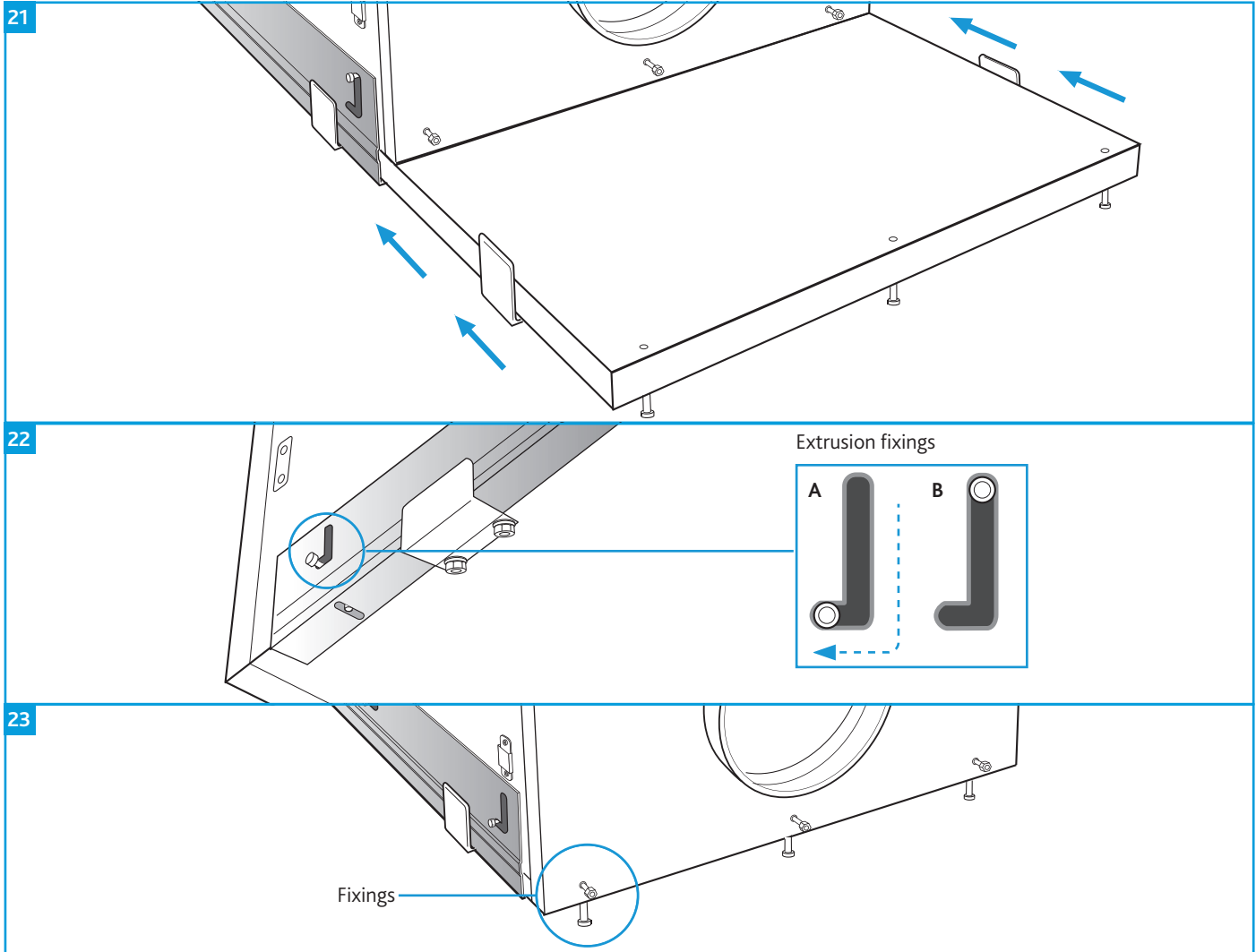

4.9.2 AVT 7-9 Access

1. Release 6 base fixings, 3 each end of each access panel (note captive fixings).
2. Release 6 lower end panel fixings, 3 each end of the unit.
3. Lower the 2 runner mechanisms containing each side of the unit so the runner fixings move to the top of the cut-out slots shown below. When completed the runners / access panel(s) will drop down by the depth of the cut-out slots, enabling the access panel(s) to be slid open.
4. Slide access panel(s) open along the inside of the runner mechanism to gain access to the blowers.
5. To close the access panel(s) slide the access panel(s) back to the original aligned position.
6. Lift the runner mechanism (on each side of the unit) containing the access panel(s) to the original positions so that the runner fixings move back to the bottom of the cut-out slots as shown in (A) Fig 17d and re-set the plungers in the closed position.
7. To complete closure of the access panel(s) and make secure, re-tighten 6 lower end panel fixings, 3 each end of the unit and then the 6 base fixings, 3 each end of each access panel.

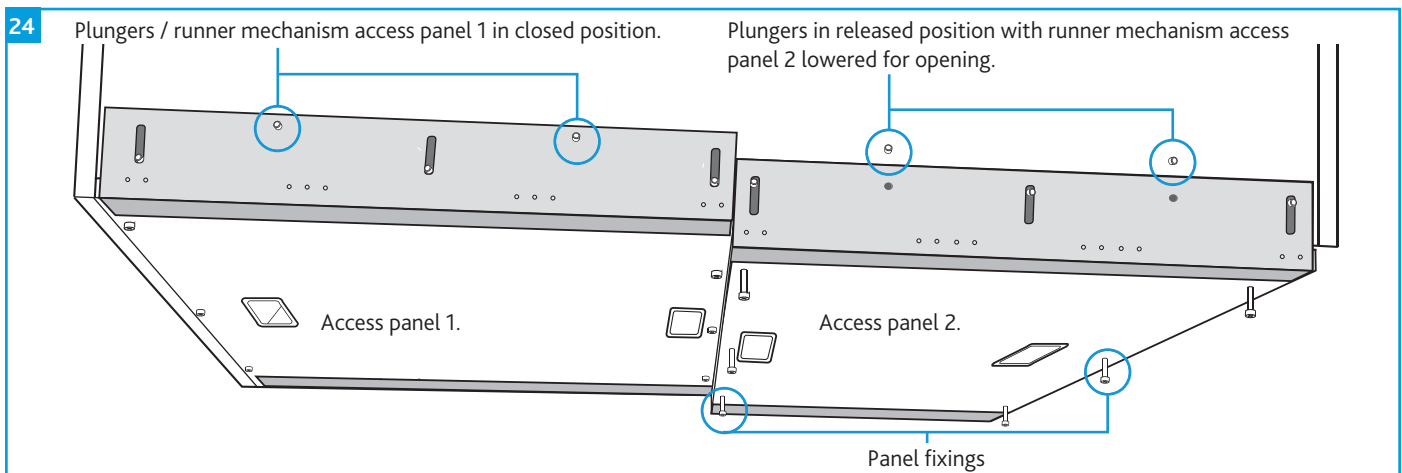

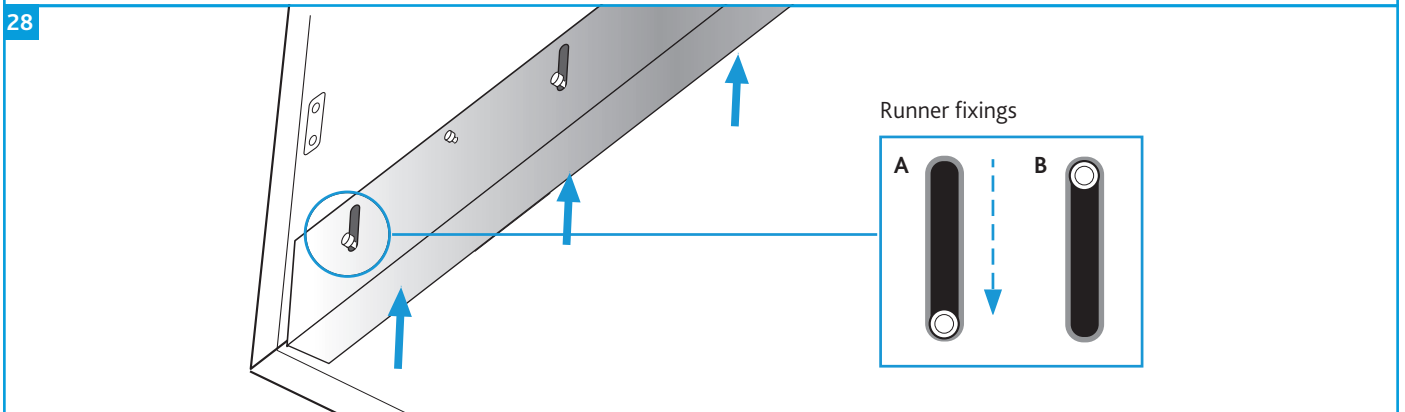
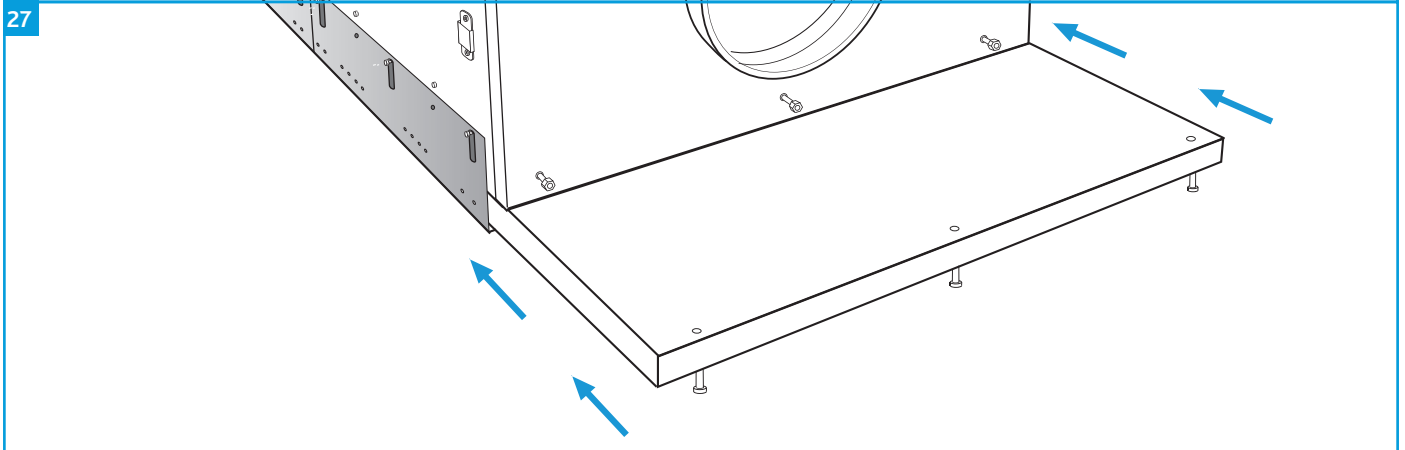
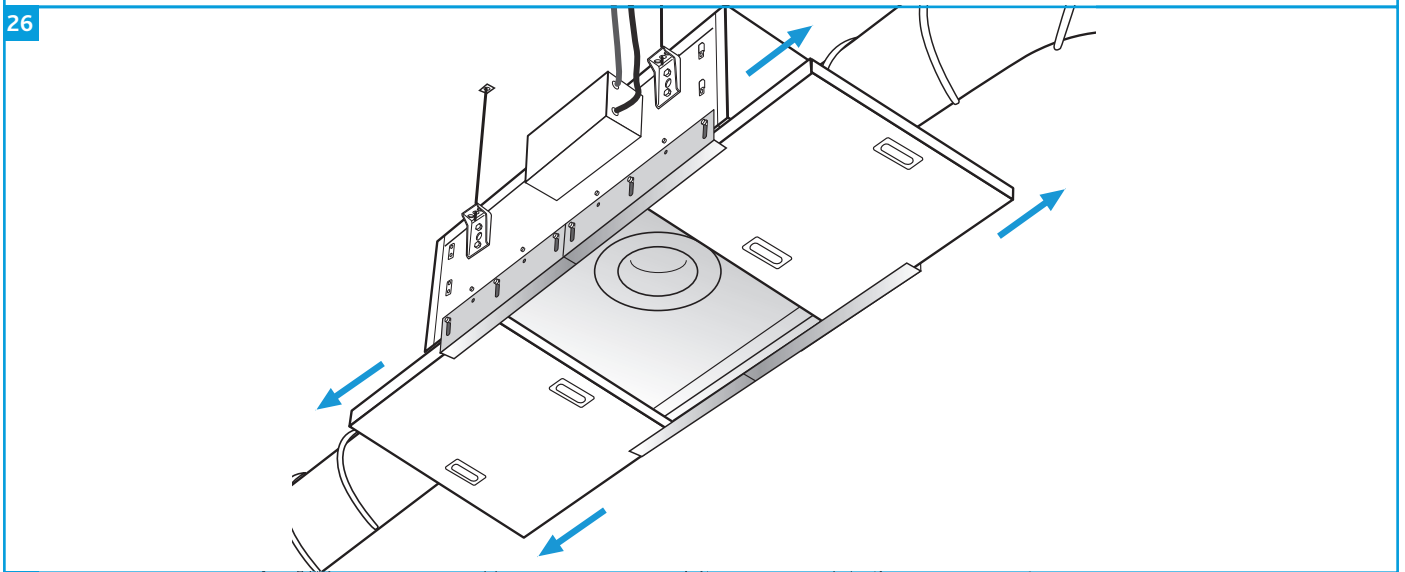
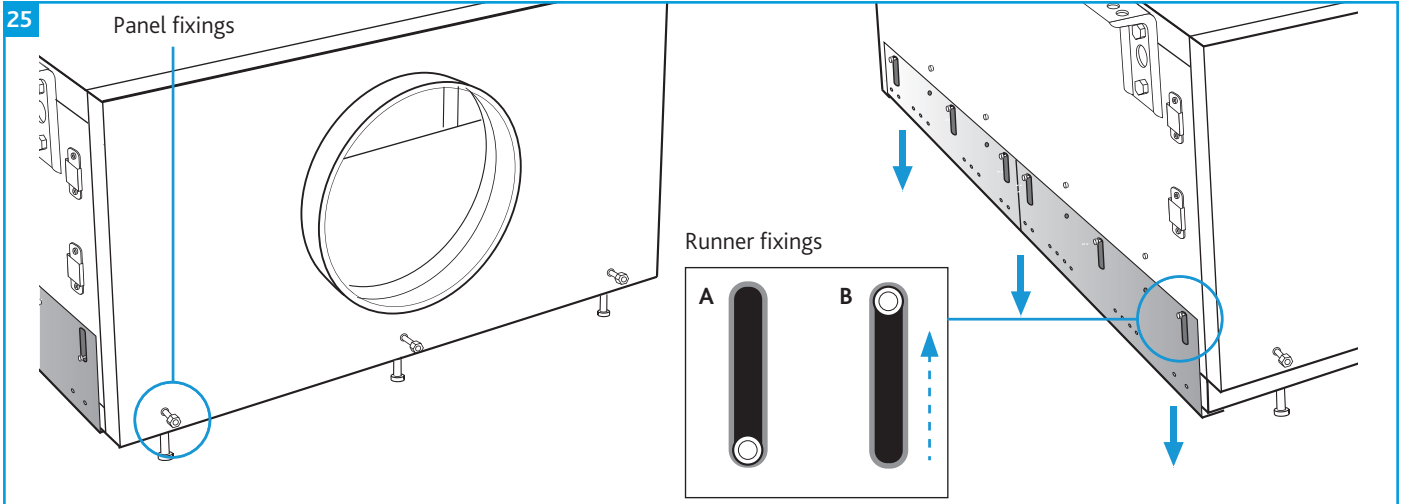

29

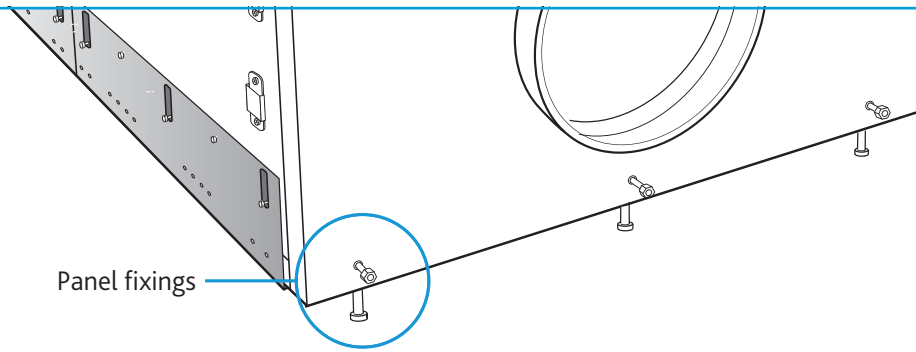

4.10 Changing Control Handing (AVT1-8 Only)

Choose your required control handing prior to unit installation.

1. Remove access cover.
2. De-couple control harness from main harness and remove control from unit complete with cable seal.
3. Re-route cable to opposite side of unit (Note: Units 5-7 have internal handing harness), remove blanking plate and cut insulation to allow the control harness to be fed through the side panel. Refit control and cable seal and feed control harness and connect to internal harness or handing loom.
4. When fitting lid (units 1-4) ensure lid is in the correct configuration as shown.

30 Relocating Control - Step 1

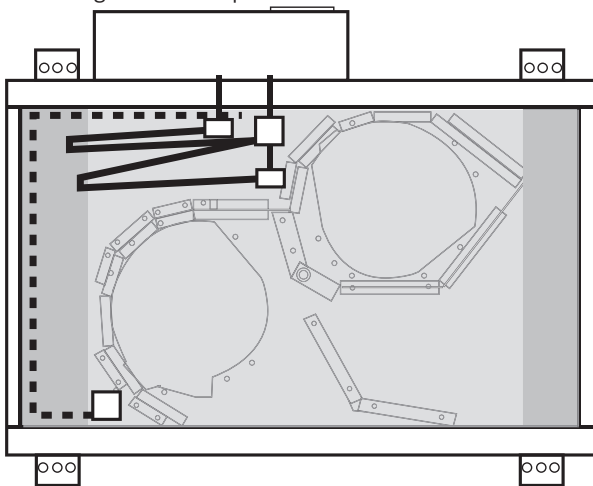

31 Relocating Control - Step 2

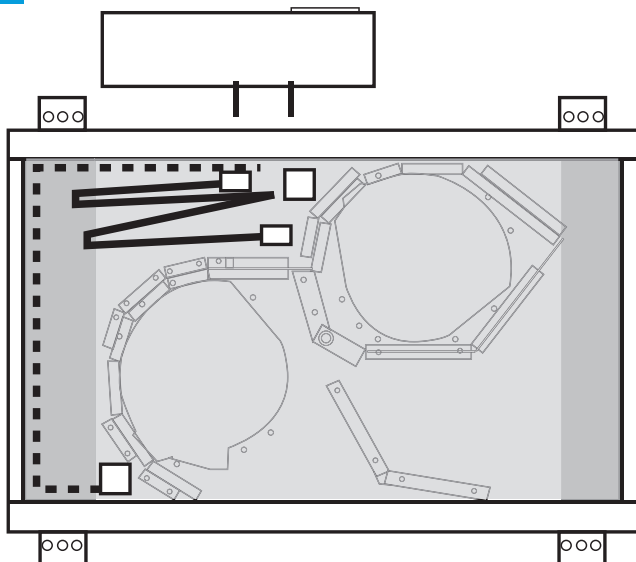

32 Relocating Control - Step 3

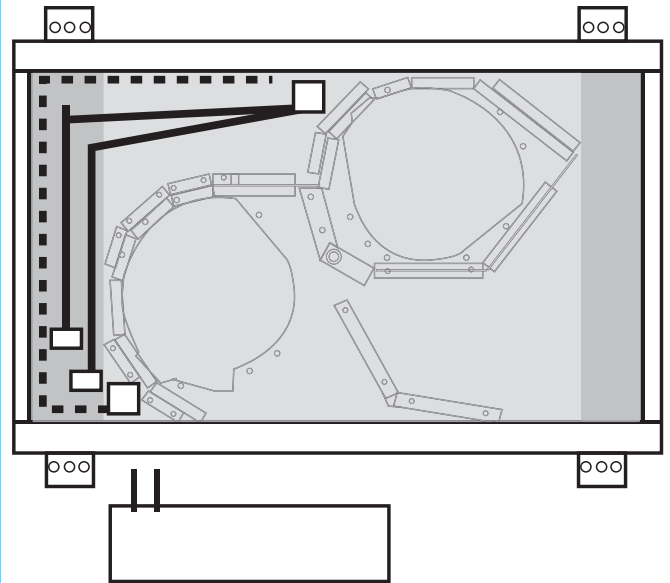

33 Relocating Control - Step 4

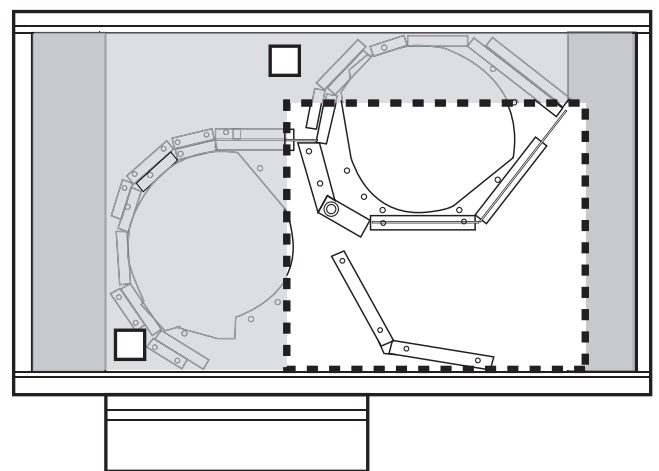

5.0 ELECTRICAL INSTALLATION

Before commencing work make sure that the unit, switched live and Nuair control are electrically isolated from the mains supply.

Because the run and start currents depend upon the duty and associated ductwork of an individual unit, run currents will be exceeded if the unit is operated with its cover removed. It is therefore recommended that the unit is not run for prolonged periods in this condition.

5.1 Wiring Diagrams

All inter-connections between circuit boards, blowers and sensors are made at the factory. These diagrams only show the essential field wiring points for clarity.

*Remove link wire if switched live signal, an enabler or BMS signal is connected.

5.1.1 AVT 1-8

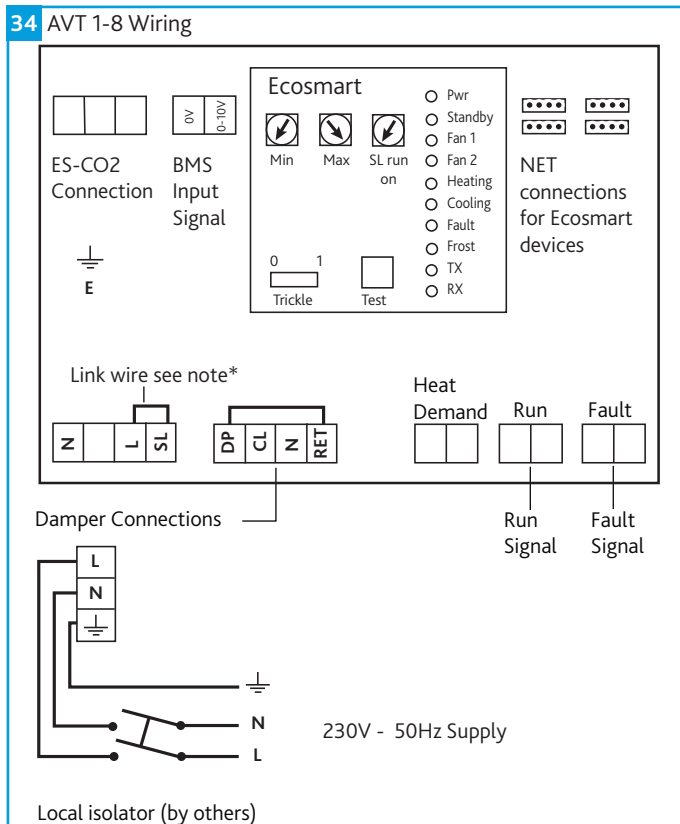

5.1.2 AVT 9

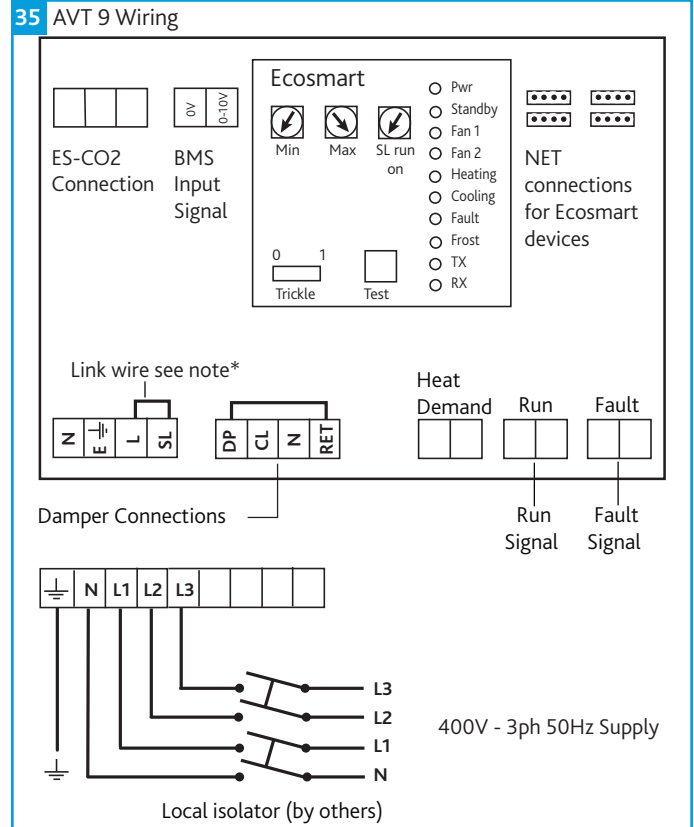

5.1.3 Control Module

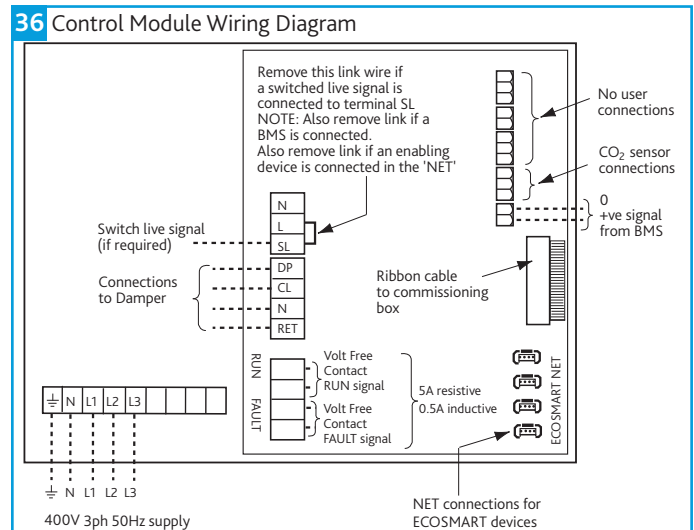

5.2 Post Installation Testing

- Ensure that the fan unit and any specified controls are fitted securely according to the instructions.
- Switch on the mains supply.
- Push the test button to run the unit fan and check it runs satisfactorily.
- If a switched live signal is used, activate this signal and check that the fan runs. De-activate the switched live signal and check the run-on time; adjust if necessary.
- Adjust the set point of any sensors and PIR; check they function correctly.
- Adjust the maximum and minimum airflow (if required) by following the commissioning procedures.

5.3 Electrical Connections

5.3.1 Mains Connections

Mains cables should be suitably sized and terminated at terminals shown on the appropriate diagram.

5.3.2 Control Connections

NET - 4 IDC plug-in connectors are provided for the connection of compatible sensors, manual controls and for linking the fans together under a common control. If more than 4 connections are required, the junction box (product code ES-JB) should be used (see data cable installation).

37 Control Connections

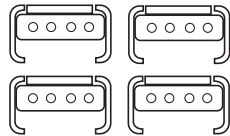

5.3.3 Switched Live (SL) Terminal

A signal of 100-230V a.c. will activate the fan from either its off state or trickle state (see setting to work-trickle switch). When the SL is disconnected the fan will over-run (see setting to work-timer adjustment). **Do not take this signal from an isolating transformer.**

38 Switched Live Terminal

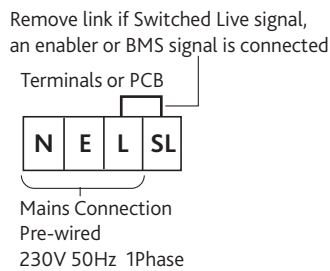

5.3.4 Damper Connections

OP - 230V 50Hz 1A max supply to open the damper

CL - 230V 50Hz 1A max supply to close the damper

N - Neutral supply to damper

RET - 230V ac return signal from the damper limit switch indicates the damper has reached its operating position. If the return signal is not present, the fan will wait for 1 minute before starting. **If a damper is not fitted, connect a link wire from OP to RET. This will cancel the delay.**

39 Drive Open / Drive Close Damper Connection

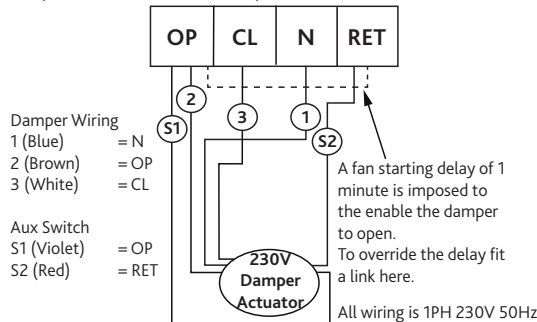

40 Drive Open / Spring Close Damper Connection

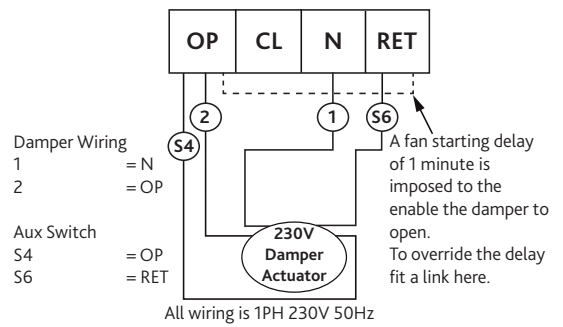

5.3.5 Volt Free Relay Contacts

41 Volt Free Relay Contacts

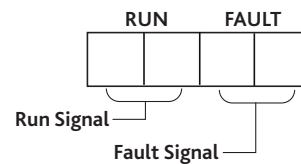

5.3.6 Data Cable Installation

A 4-core SELV data cable is used to connect devices such as sensors to the fan and for interconnecting multiple fan units.

For good EMC engineering practice, any sensor or low voltage data cables should not be placed within 50mm of mains cables or placed on the same cable tray or conduit as mains cables.

The maximum cable run between any two devices is 300m when it is installed in accordance with the instructions. The total data cable length used in any system must be less than 1000m. Keep the number of cable joints to a minimum to ensure the best data transmission efficiency between devices + 50m or less for ES-LCD.

5.3.7 Maximum Number Of Devices

The maximum number of devices (including fans) that can be connected together via the data cable is 32, irrespective of their functions.

5.4 BMS Input Signals

42 BMS Connector

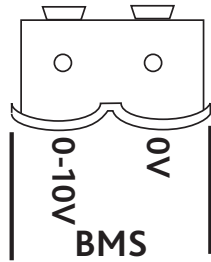

BMS Input Signals and other low voltage cables should Follow the basic principles set out in (Section 5.3.6).

The BMS connection is made with a plug-in connector via the socket (Figure 42). To ensure the connection is made only by suitably qualified and authorised personnel, the plug is not supplied. It is **available from R S Components, Part No. 176-7772**. Reversal of the BMS connection will damage the control.

The system’s response to a 0-10V dc BMS signal is given in the table below. The voltage tolerance is +/- 125mV and is measured at the fans terminal. **The BMS signal will override any sensors and user control connected in the system.**

	Ventilation Mode	Cooling Mode*	Heating Mode*
Local Control	0.00	-	-
OFF/ Trickle	0.25	-	-
Speed 1	0.50	0.75	1.00
Speed 2	1.50	1.75	2.00
Speed 3	2.50	2.75	3.00
Speed 4	3.50	3.75	4.00
Speed 5	4.50	4.75	5.00
Speed 6	5.50	5.75	6.00
Speed 7	6.50	6.75	7.00
Speed 8	7.50	7.75	8.00
Speed 9	8.50	8.75	9.00
Speed 10	9.50	9.75	10.00

* Only available on relevant unit.

6.0 CONTROLS

6.1 LED Indication

- PWR** GREEN: Power on & OK. RED: To much power is taken by peripherals or there is a short circuit in the net cable. Check the cable and use a junction box (ES-JB) to connect some of the peripherals
- Standby** LED on when fan is not running.
- Fan 1** GREEN: Fan 1 is running, RED: Fan 1 faulty.
- Fan 2** GREEN: Fan 2 is running, RED: Fan 2 faulty.
- Heating*** GREEN: Heating selected RED: Heating faulty.
- Cooling*** Not applicable. See note.
- Fault** LED on when a fault is present on unit.
- Frost*** Not applicable. See note.
- TX** LED on when the controller is transmitting data.
- RX** LED on when the controller is receiving data.

*** The control panel is common to all the Ecosmart products and will have indicators for functions that are not available in this particular fan. However these indicators will not be illuminated.**

A Commissioning Procedure document (Document No. 671153) is available on request from Nuair.

43 Commissioning Panel Details

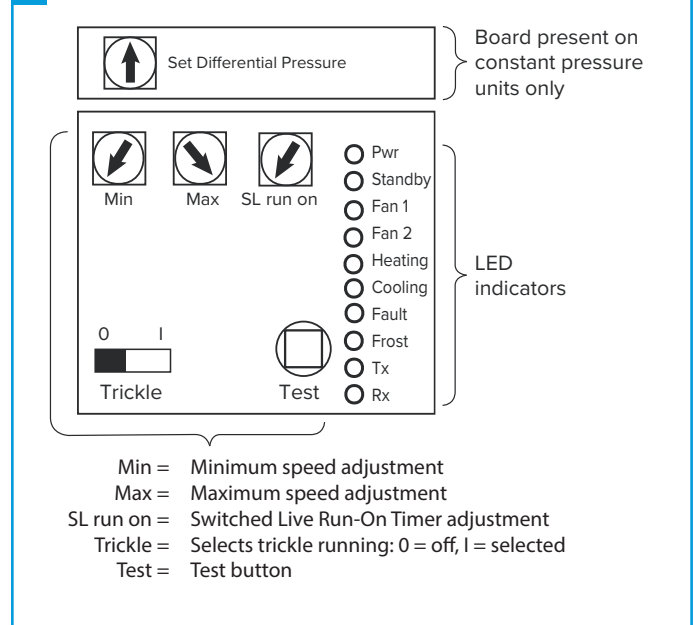

6.2 Using Test Button

The test button allows the individual blowers within the unit to be checked for its operation. If the fan is running already, press the button once to stop the fan, press again to switch on the standby fan, press again to stop and so on. **The fan will return to normal operation after 30 seconds.**

6.3 Setting Unit Airflow

6.3.1 Maximum Airflow

Ensure the power supply is switched off and that a link wire is connected from the supply L to the SL terminal. Unplug all items connected to the 'Net' connectors.

Switch on the power supply. **Ensure unit cover is securely attached.**

Wait for the fan to complete its self-test operation.

Remove the cover of the units external commissioning box. Measure the airflow using standard commissioning instruments at a suitable point in the ductwork. If adjustment is required, rotate the pot marked 'MAX' to obtain the desired airflow.

6.3.2 Minimum Trickle Airflow (Nominally 40%)

Repeat the same procedure as for maximum airflow above but without the link wire between supply L and SL terminal. Ensure the trickle switch is in the 'ON' position. The adjustment must be made on the pot marked 'Min'.

The minimum setting (nominally 40%) must be below the maximum setting, otherwise minimum setting will be automatically set to be the same as the maximum.

After setting the airflows, re-connect all the items disconnected previously. Ensure that the cover over the mains terminals is replaced and that the cover of the controls enclosure is securely fastened.

6.3.3 Setting the Operating Pressure

Select a suitable location on the inlet side of the fan to read the static pressure of the system. This should be a straight section of ductwork, away from any obstructions or bends. Read the static pressure at this point using suitable instruments. If the control pressure tapping has been moved because of ancillaries fitted to the fan inlet, measure the static pressure at the new location.

Adjust the pressure setting using the potentiometer labelled for this purpose in the commissioning box until the pressure of the system reaches the desired level. The adjustment should be made slowly and allow the system to settle (approx. 30 seconds) before reading the pressure.

7.0 MAINTENANCE

It is important that maintenance checks are recorded and that the schedule is always adhered to, in all cases, the previous report should be referred to.

7.1 Routine Maintenance

- Clean all areas of unit and treat any areas of corrosion.
- Check all access doors for leakage and if necessary locks should be adjusted and any replacement gasket materials should be replaced as required.

7.2 Annually

- Thoroughly inspect the unit and its components for corrosion, acting immediately to treat/restore any damaged areas.
- All electrical terminals within the unit should be tightened.
- Check all earth connections.
- Check control dampers blades.
- Check operation of damper actuators and linkages and adjust as necessary.

8.0 WARRANTY

The 5 year warranty starts from the day of delivery and includes parts and labour for the first year. The remaining period covers replacement parts only.

This warranty is void if the equipment is modified without authorisation, is incorrectly applied, misused, disassembled, or not installed, commissioned and maintained in accordance with the details contained in this manual and general good practice.

The product warranty applies to the UK mainland and in accordance with Clause 14 of our Conditions of Sale. Customers purchasing from outside of the UK should contact Nuaire International Sales office for further details.

Failure to maintain the unit as recommended will invalidate the warranty.

9.0 END-OF-LIFE AND RECYCLING

Where possible Nuaire use components which can be largely recycled when the product reaches its end-of-life:

- Fans, motors, controls, actuators, cabling and other electrical components can be segregated into WEEE recycling streams.
- Sheet metal parts, aluminium extrusion, heating/cooling coils and other metallic items can be segregated and fully recycled.
- EPP, plastic ducting, nylon corner pieces, plastic heat exchangers, packaging material and other plastic components can be segregated into mixed plastic and widely recycled.
- Cardboard packaging, wood, used filters and other paper components can be largely recycled or fully processed in energy from waste centres.
- Remaining Items can be further segregated and processed in accordance with the zero waste hierarchy. Please call After Sales Support for further information on items not listed above.

Ensure that Nuaire product is made safe from any electrical / water / refrigerant supplies before dismantling commences. This work should only be undertaken by a qualified person in accordance with local authority regulations and guidelines, taking into account all site based risks.

10.0 AFTER SALES AND REPLACEMENT PARTS

For technical assistance or further product information, including spare parts and replacement components, please contact the After Sales Department.

If ordering spares please quote the serial number of the unit together with the part number, if the part number is not known please give a full description of the part required. The serial number will be found on the identification plate attached to the unit casing.

10.1 Replacing Fan / Motor

The only items of the fan units unit likely to require replacement are the fan/motor assemblies due to a failed motor or damaged impeller or damper actuator.

Remove the access cover. Disconnect the incoming wiring from the connection box (located on the fan scroll) on the particular fan/motor assembly to be removed.

Remove the fan/motor fixings completely, other than the two slotted hole fixings. Support the fan/motor assembly and loosen the slotted hole fixings. The fan/motor assembly can now be turned and withdrawn from the unit.

After replacing the faulty item, refit the fan motor/assembly using the slotted hole fixings to assist in supporting the assembly. Re-connect the wiring. Replace the access cover.

Telephone 02920 858 400
aftersales@nuaire.co.uk

Technical or commercial considerations may, from time to time, make it necessary to alter the design, performance and dimensions of equipment and the right is reserved to make such changes without prior notice.

