



# Natural Ventilation

ε-stack S-Series Stack Based  
Ventilation System

## Installation and Maintenance

### Important Notes to Designers and Installers

The Nuair e-stack S-Series SI200 and SI500 ventilation systems operate under a natural upwards displacement strategy in summer and a high level mixing mode in winter. The winter mode exploits the heat gains in the building to temper the incoming fresh air, dramatically reducing the heating energy required for the building.

#### Winter mode

In winter the system operates under a mixing strategy, where the cold incoming air is mixed with the warm air in the room. The heat gains within heavily occupied spaces (e.g. school halls) are often sufficiently high that additional heating is not needed until the external temperature falls to somewhere in the range 5 - 10°C, depending on the U-value for the room. This is in contrast to traditional upwards displacement systems that require heating from much higher external temperatures.

#### Summer mode

Once the external temperature has increased such that air can be brought in at low level directly onto occupants without pre-heating, the ventilation strategy for the system changes to a natural upwards displacement mode.

This strategy does not require wind to drive the flow, so ventilation is provided throughout the summer, even on still days.

#### Fans

Although airflow in summer is mainly buoyancy driven, the two low energy fans in the unit (that are primarily used for winter mixing) can be used to boost airflow through the space in warmer weather.

#### Controlled ventilation

The ventilation system is fully controlled with dedicated temperature and CO<sub>2</sub> sensors in the space. This allows the system to optimise the ventilation strategy for comfort and energy use.

Figure 1. e-stack S-Series isometric.

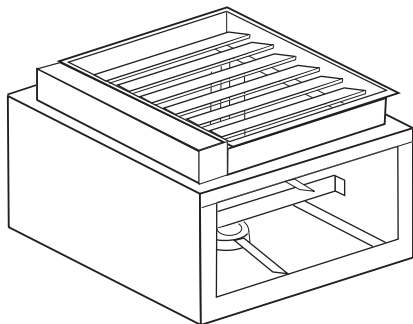

#### Construction

S-Series Ventilation units are constructed with Galvanised or Zintec steel. The units can be supplied in Standard galvanised finish or Zintec powder coated to RAL9010 as standard.

The S-Series units have been acoustically tested in accordance with BS EN 20140-10:1992 and ISO 140-10:1991 and are shown to meet the requirements of BB93 – Acoustic Design of Schools.

### I.O Handling

Each e-stack S-Series unit is delivered to site suitable for forklift handling. Unit weight is displayed on the packaging. (approx 200kg for S-1500 and 150kg for the S-1200 with grilles and pallet).

Offloading and positioning of the equipment is the responsibility of the purchaser.

Spreaders should be used when lifting with slings to avoid damage to the casings. Care must be taken to ensure that slings are correctly positioned to avoid crushing and twisting of the unit castings.

Where channels and/or support frames are bolted to the underside of the unit casing, slings or fork-lift arms should be positioned to locate in the apertures in the channels.

Figure 2. Lifting examples.

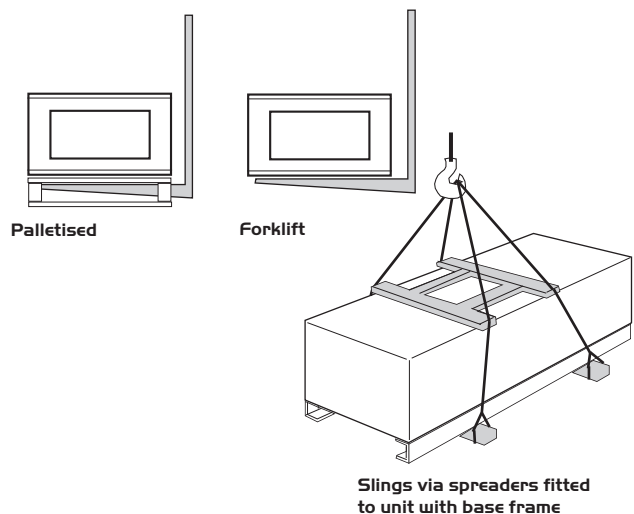

### 2.0 Installation

Installation must be carried out by competent personnel in accordance with the appropriate authority and conforming to all statutory and governing regulations e.g. I.E.E., CIBSE, COHSE etc.

#### 2.1 Opening requirements

To provide sufficient ventilation in summertime operation an opening area at low-level of 1.0 sq.m effective aerodynamic free area should be provided for the SI200 and 1.5 sq.m for the SI500, by means of opening windows and/or low-level dampered inlets. This area is per S-Series unit. Hence, in spaces containing n number units, this should be increased to n x 1.0 sq.m effective aerodynamic free area for the SI200, and increased to nx 1.5 sq.m for the SI500.

## 2.2 Installation of the S-Series units

Whilst Nuair provide recommendations for the installation of supports for the units, the sizing and detailed design of the load-bearing supports must be specified and signed off by the structural engineers for the project. Two fixing methods are suggested:

1. Vertical support studding attaches to either side of a cradle which supports the e-stack unit. The cradle can be formed from a unistrut channel.

Figure 3. Option 1. Unistrut channel cradle.

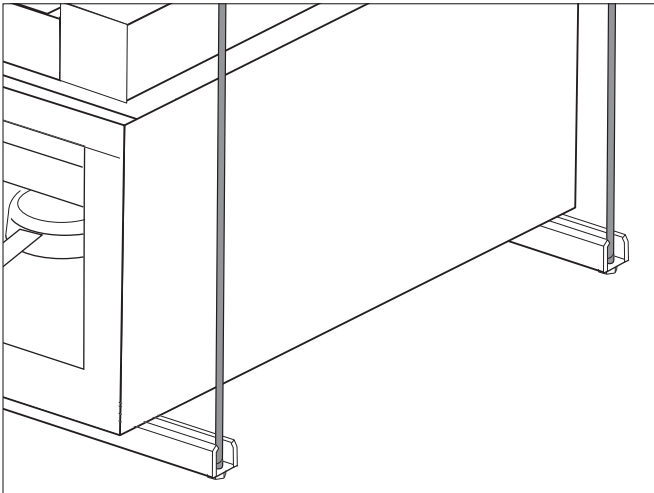

2. e-stack mounting brackets supplied (at additional cost) and used in conjunction with drop-rods to support the units. (see figures 4 and 5).

Ventilation unit hangs from 4no. pieces of M12 studding of maximum length 1200mm.

Drop-rods attached to S-Series unit using welded brackets (supplied at additional cost).

The bracket length is 65mm to the centre of the fixing hole.

Figure 5. Option 2, close up of bracket.

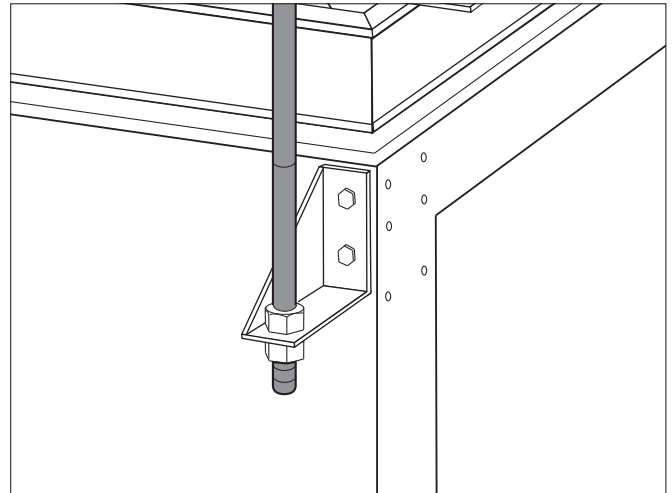

The unit is lifted into place and four M12 Studding (drop-rods) are brought through the holes on the end of the welded brackets, positioned and secured in place using a pair of M12 full nuts per bracket. (see figure 4).

Figure 4. Option 2, showing drop rods attached to unit.

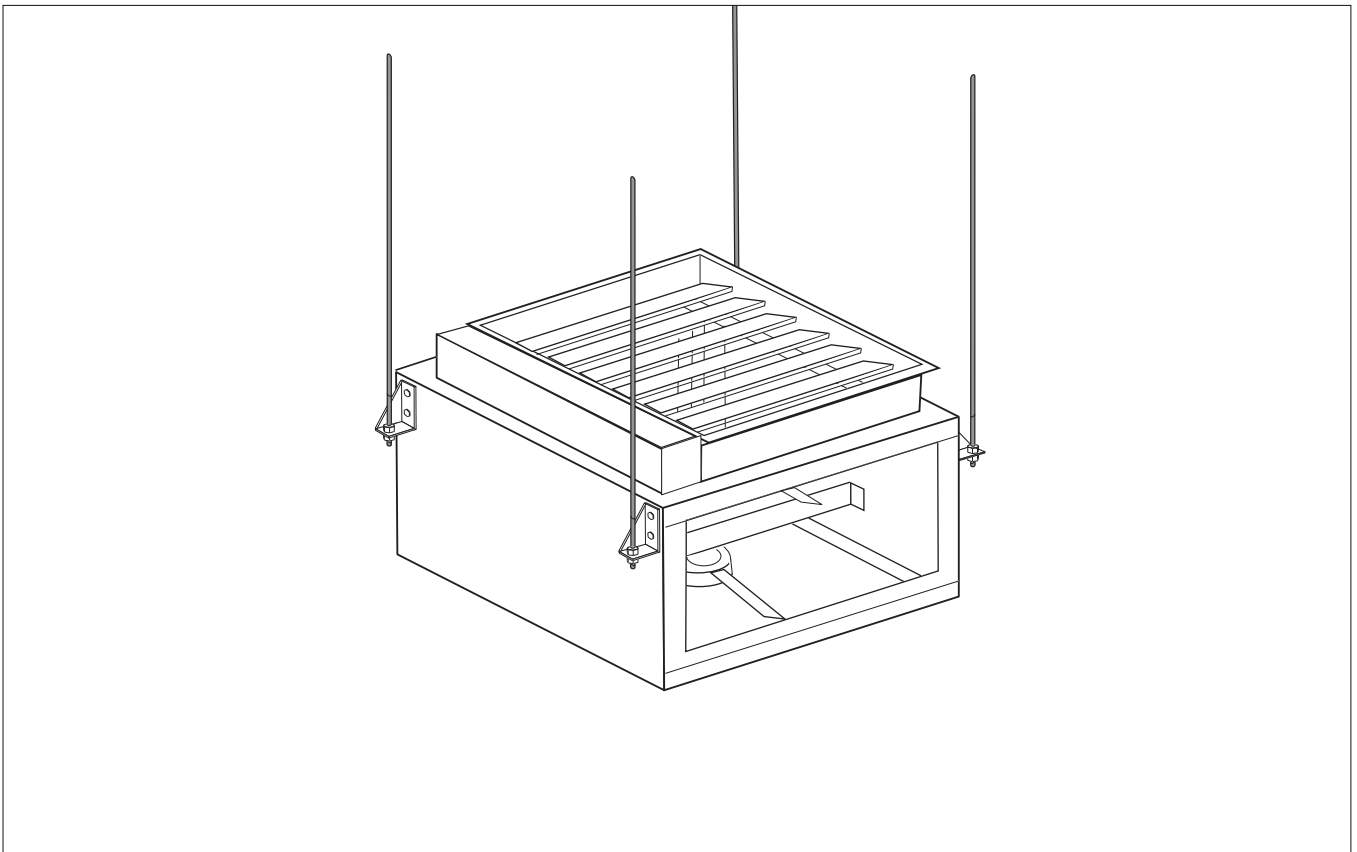

### 2.3 Shaft Specification

A square shaft with annulus between each S-Series unit and roof termination is required. The specification of this is shown in figures 6a, 6b and 7.

### 2.4 Grille Requirements

e-stack units contain fast moving fans and must have grilles on all open faces when in operation.

- Where the base of the unit is installed less than 2.7m vertical distance from the floor, specific grilles provided by Nuairé must be used.
- Where the unit is installed more than 2.7m vertical distance from the floor, grilles can optionally be provided by Nuairé.

**Figure 6a.** (Section view of unit installed without a suspended ceiling in conjunction with a roof terminal and shaft with insulation removed for clarity).

All components by others except where stated.

**Figure 6b.** (Section view of unit installed above a suspended ceiling in conjunction with a roof terminal and shaft with insulation removed for clarity).

All components by others except where stated.

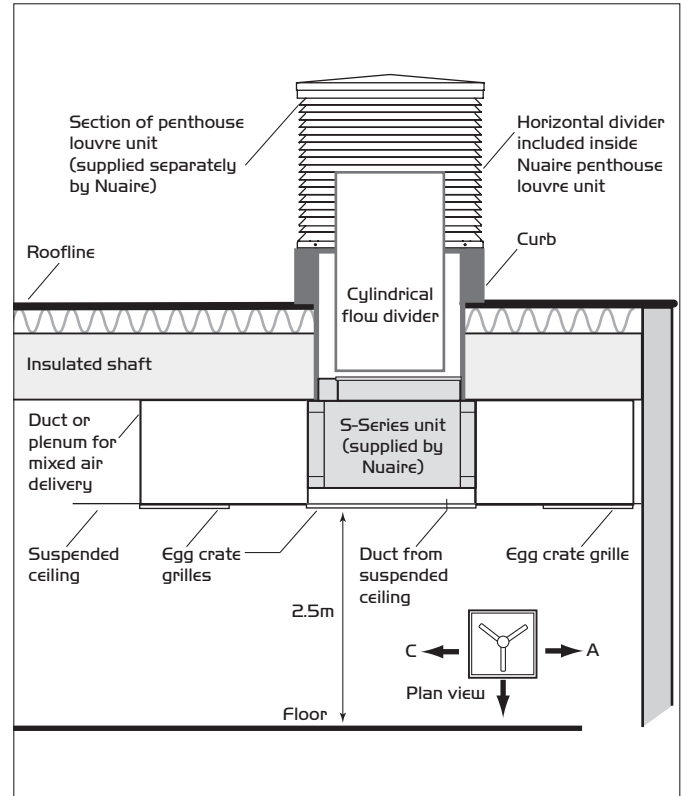
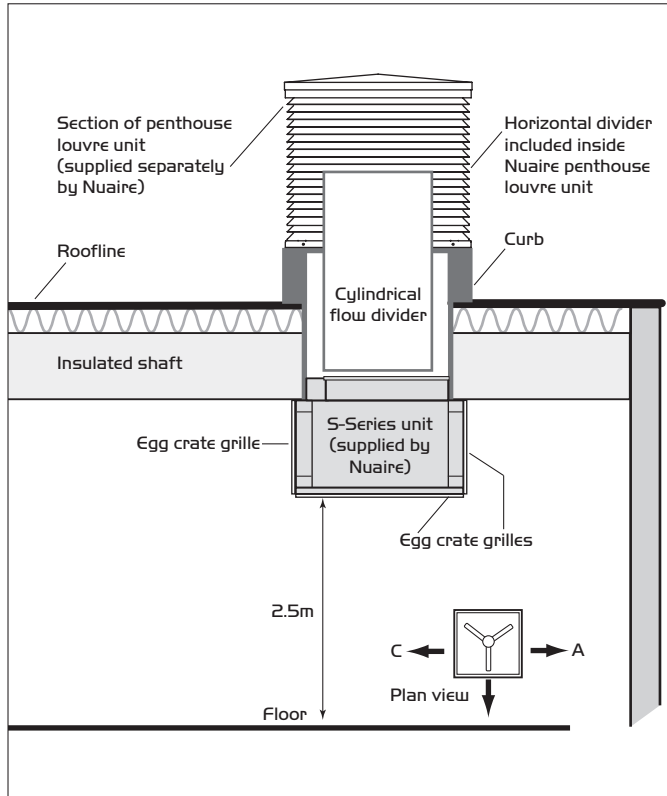

**Figure 7.** Typical square shaft detail.

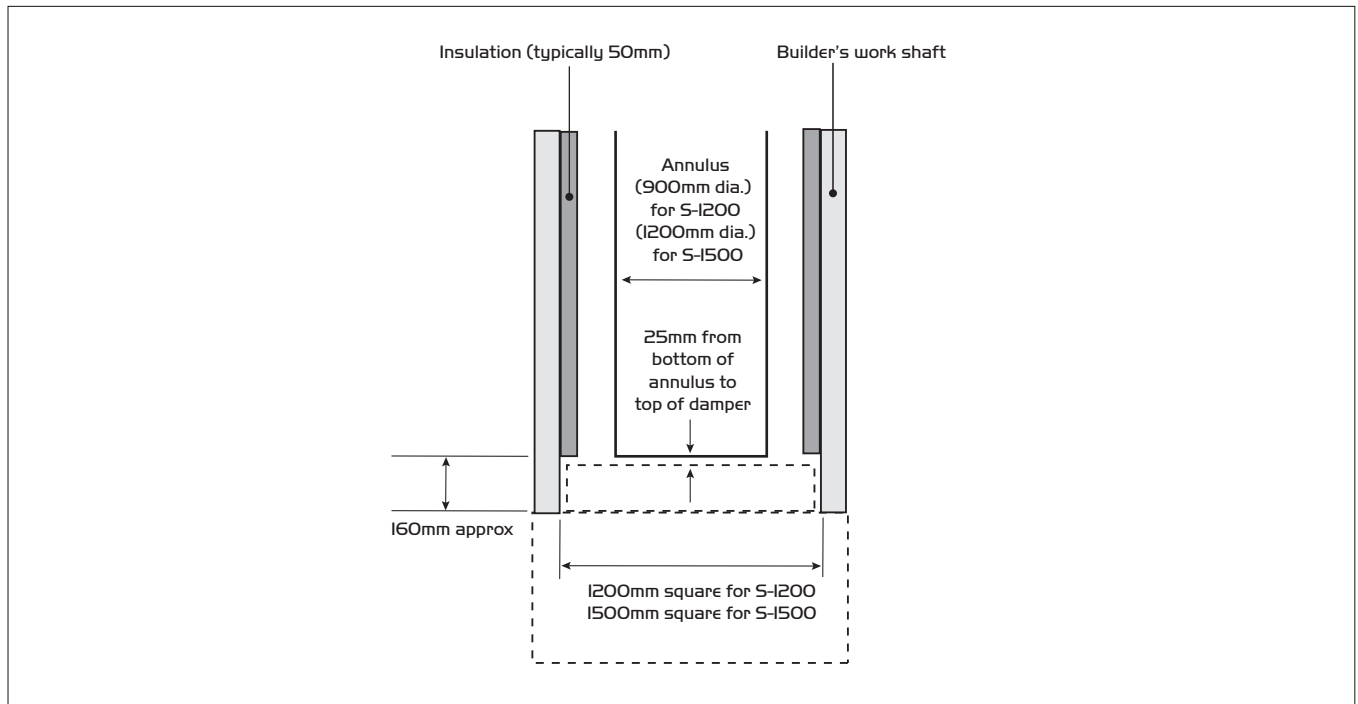

## 2.5 Electrical Installation

Installation must be carried out by a qualified electrician in accordance with the appropriate authority and conforming to all statutory and governing regulations.

- Cable size to be determined by volt-drop calculation by others but must be at least 1.0mm<sup>2</sup> per core
- Cables must have dielectric strength test capability of 2KV for 5mins
- The Neutral (and only Neutral) must have light blue coloured insulation
- All cabling must be copper
- Fused Connection Units (FCUs) are readily available from main electrical suppliers and fit standard IG 25mm back boxes. The unit should be mounted between 0.6m and 1.9m above the floor. The fuse should be chosen to suit the number of units powered by the spur.

## 2.6 Room Key Switch

An ON/OFF/TEST switch is supplied to control the mode of the S-Series unit.

This is typically supplied as a key switch as a means of reducing unwanted interference with the system. The TEST setting will instigate a test routine, where the fans and dampers will operate in turn to allow easy inspection as part of the maintenance regime. The key switch is to be installed between 0.6 and 1.9m above the floor.

### Room Key Switch Dimensions (mm)

85mm wide x 85mm high. Unit requires 47mm switch plate back box.

### Terminals

32	24V DC+
33	On signal
34	Test signal

### IMPORTANT

For good EMC engineering practice, any sensor cables or switched live cables should not be placed within 50mm of other cables or on the same metal cable tray as other cables.

## 2.7 Sensors

### Exterior Temperature Sensor

This sensor (supplied) should be located on the exterior facade, preferably in a permanently shaded position e.g. below roof eaves. If this is not possible, it should be positioned in a location receiving minimal direct sunlight, and not on a south facing facade where the largest direct solar radiation is observed.

One outside temperature sensor can supply a signal for up to 5 S-Series units. However, each outside temperature sensor should be powered from one unit only. Signal and ground connections to the external temperature sensor should be wired to all 5 S-Series units receiving a signal from that sensor. (see page 5 for wiring diagram).

### Room Temperature and CO<sub>2</sub> Sensors (combined)

One (supplied) for each room containing e-stack units.

This should be mounted at eye-level and away from windows or doors in frequent use, as these may locally reduce CO<sub>2</sub> concentrations. (see page 5 for wiring diagram).

## 2.8 Room Indicator LED Panel

This indicates to the user when to open or close the windows in installations with manually opening facade windows. A blue LED illuminates to show when the user should shut the windows and a red LED when the user should open the windows.

This display should be located where it is most visible to the occupants of the room.

The room indicator panel requires a 50mm deep switch plate box.

### Room Indicator Panel Dimensions (mm)

146mm wide x 85mm high

### Terminals

29	24V DC for Red LED
30	24V DC for Blue LED
31	OV common ground

Figure 8. The typical wiring layout is shown below. Wiring diagrams are shown on page 5.

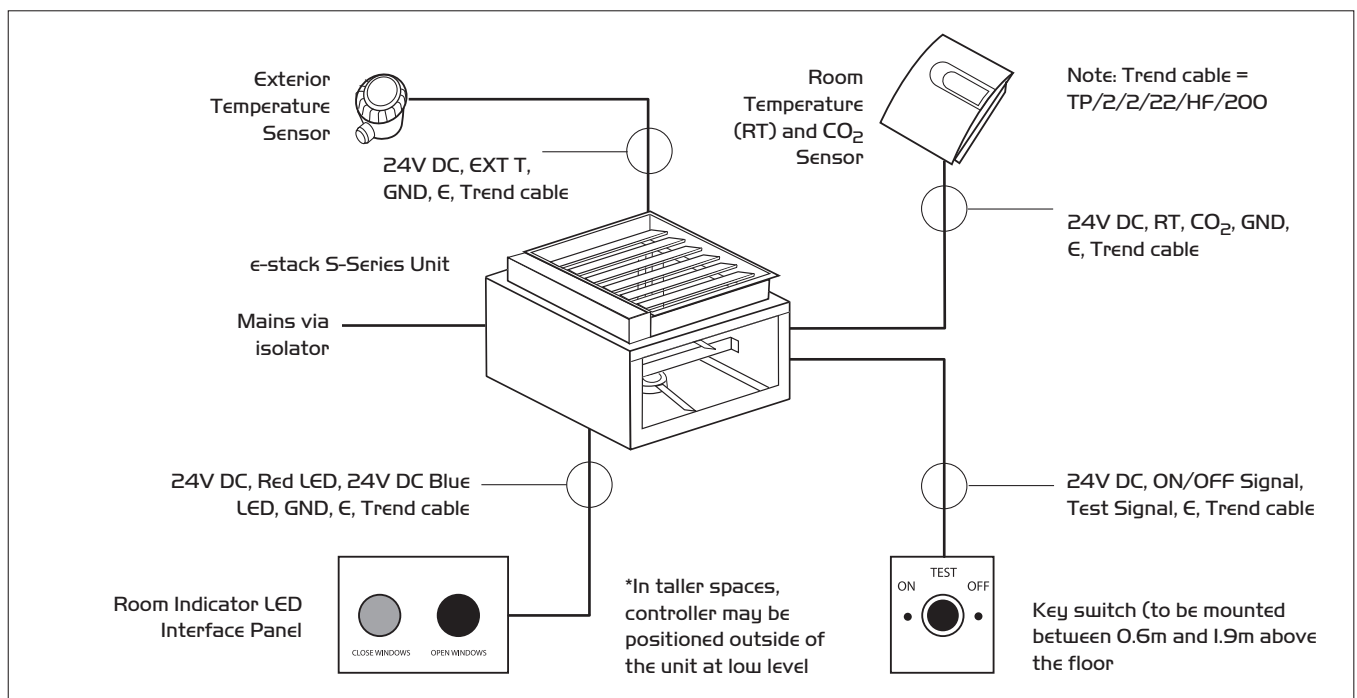

2.9 Wiring Diagrams

Figure 9. Wiring: Multiple Exterior Temperature Sensors.

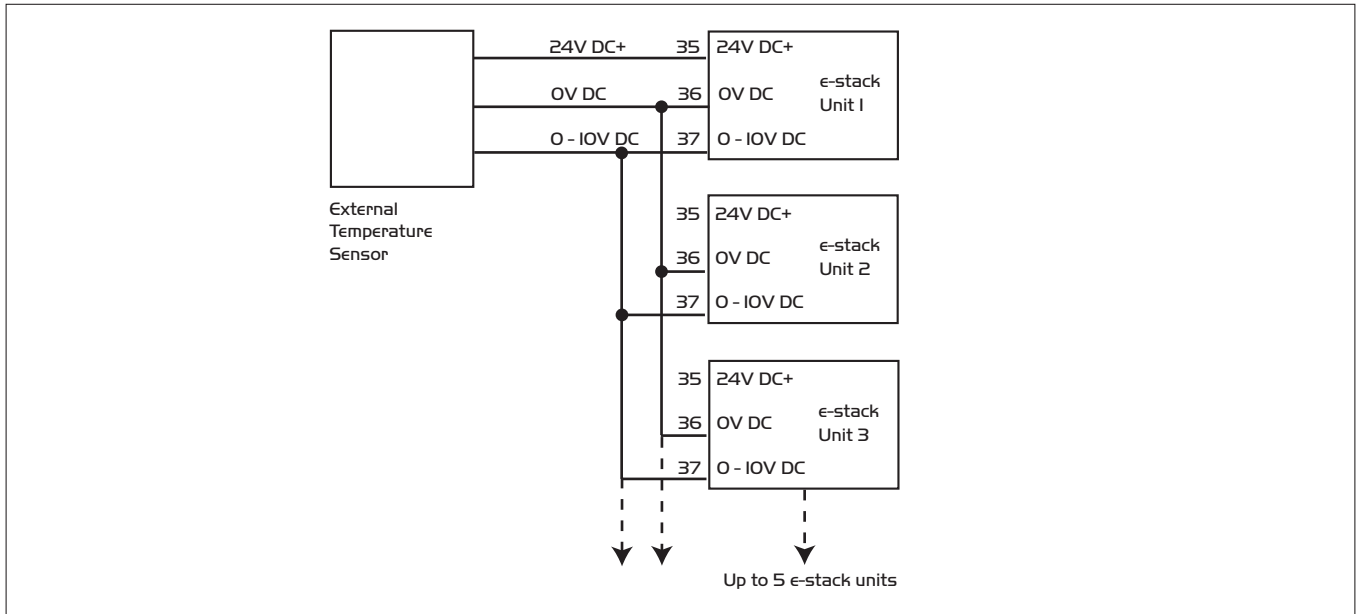
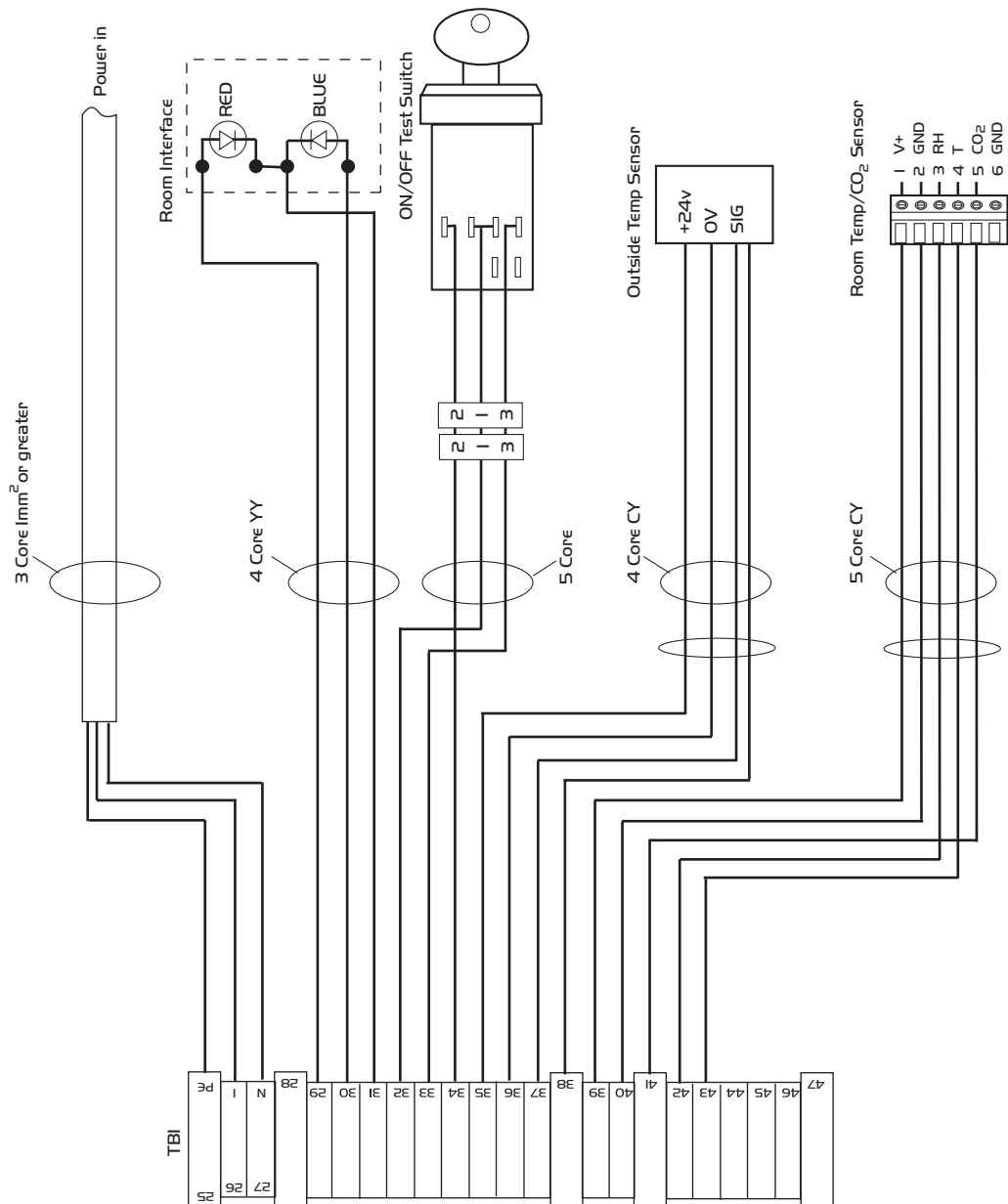
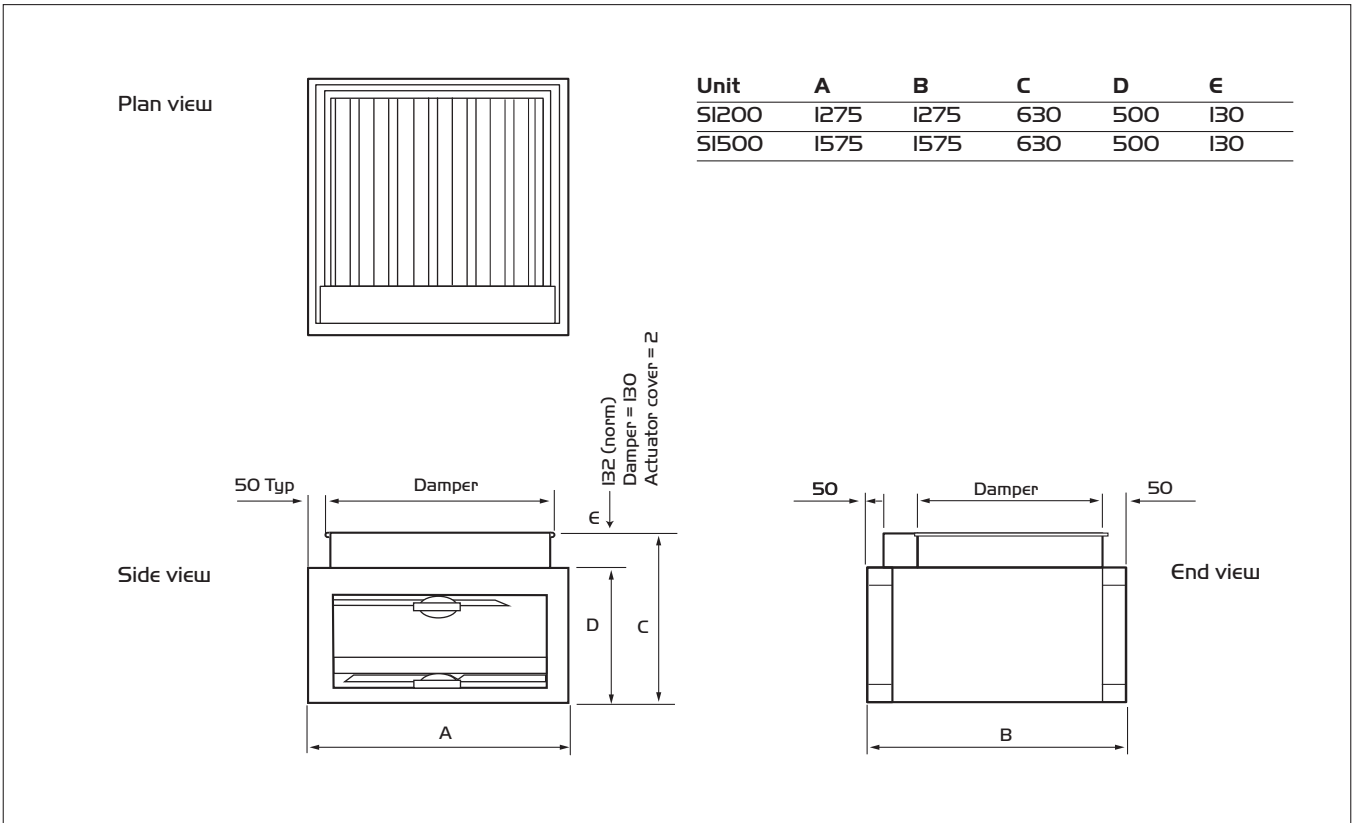

Figure 10. Electrical connections. Lower terminal strip connections are to be wired to by a site electrician when installing the units. Please use MIG compression glands provided for field wiring.



### 3.0 Dimensions e-stack S-Series (mm)

Figure II.



### 4.0 Maintenance

A 6 monthly inspection is required and any debris removed.

### 5.0 Warranty

The 3 year warranty starts from the day of delivery and includes parts and labour for the first year. The remaining 2 years covers parts only. This warranty is conditional on planned maintenance being undertaken.

### 6.0 Service Enquiries

Nuaire can assist you in all aspects of service. Our service department will be happy to provide any assistance required initially by telephone and if necessary arrange for an engineer to call.

**Telephone 029 2085 8400**

### 7.0 S-Series Roof Termination Options

(ask for Installation document 671533).

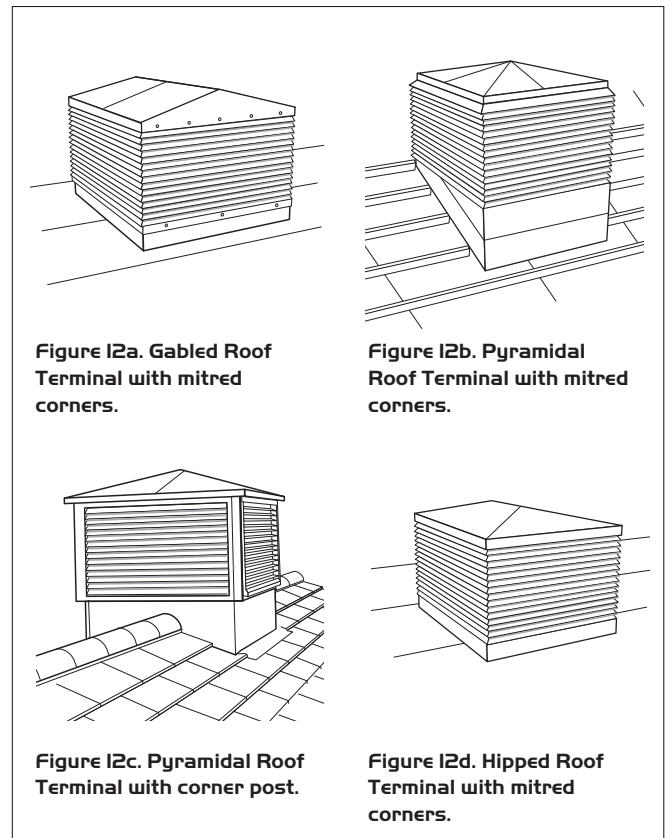

## DECLARATION OF INCORPORATION AND INFORMATION FOR SAFE INSTALLATION, OPERATION AND MAINTENANCE

We declare that the machinery named below is intended to be assembled with other components to constitute a system of machinery. All parts except for moving parts requiring the correct installation of safety guards comply with the essential requirements of the Machinery Directive. The machinery shall not be put into service until the system has been declared to be in conformity with the provisions of the EC Machinery Directive.

Designation of machinery: **e-stack S-Series**  
 Machinery Types: Natural Ventilation System  
 Relevant EC Council Directives: 2006/42/EC (Machinery Directive)  
 Applied Harmonised Standards: BS EN ISO 12100-1, BS EN ISO 12100-2, EN60204-1, BS EN ISO 9001, BS EN ISO 13857  
 Applied National Standards: BS5848 Parts 1, 2.2 and 5

### Signature of manufacture representatives:

Name:	Position:	Date:
1) C. Biggs 	Technical Director	29. 12. 10
2) A. Jones 	Manufacturing Director	29. 12. 10

Note: All standards used were current and valid at the date of signature.

## CE DECLARATION OF CONFORMITY

We declare that the machine named below conforms to the requirements of EC Council Directives relating to Electromagnetic Compatibility and Safety of Electrical Equipment.

Designation of machinery: **e-stack S-Series**  
 I & M Serial No.: 671529  
 Machinery Types: Natural Ventilation System  
 Relevant EC Council Directives: 2004/108/EC (EMC), 2006/95/EC (Low Voltage Directive)  
 Applied Harmonised Standards: EN55014-1, EN55014-2, EN61000-3-2, EN61000-3-3, EN60335-2-80  
 Basis of Self Attestation: Quality Assurance to BS EN ISO 9001 BSI Registered Firm Certificate No. FM 149

### Signature of manufacture representatives:

Name:	Position:	Date:
1) C. Biggs 	Technical Director	29. 12. 10
2) A. Jones 	Manufacturing Director	29. 12. 10

Nuaire Ltd,  
 Western Industrial Estate,  
 Caerphilly CF83 1NA.

Note: All standards used were current and valid at the date of signature.

## INFORMATION FOR SAFE INSTALLATION, OPERATION AND MAINTENANCE OF NUAIRE VENTILATION EQUIPMENT

To comply with EC Council Directives 2006/42/EC Machinery Directive and 2004/108/EC (EMC).

To be read in conjunction with the relevant Product Documentation (see 2.1)

### 1.0 GENERAL

1.1 The equipment referred to in this Declaration of Incorporation is supplied by Nuaire to be assembled into a ventilation system which may or may not include additional components.

The entire system must be considered for safety purposes and it is the responsibility of the installer to ensure that all of the equipment is installed in compliance with the manufacturers recommendations and with due regard to current legislation and codes of practice.

### 2.0 INFORMATION SUPPLIED WITH THE EQUIPMENT

2.1 Each item of equipment is supplied with a set of documentation which provides the information required for the safe installation and maintenance of the equipment. This may be in the form of a Data sheet and/or Installation and Maintenance instruction.

2.2 Each unit has a rating plate attached to its outer casing. The rating plate provides essential data relating to the equipment such as serial number, unit code and electrical data. Any further data that may be required will be found in the documentation. If any item is unclear or more information is required, contact Nuaire.

2.3 Where warning labels or notices are attached to the unit the instructions given must be adhered to.

### 3.0 TRANSPORTATION, HANDLING AND STORAGE

3.1 Care must be taken at all times to prevent damage to the equipment. Note that shock to the unit may result in the balance of the impeller being affected.

3.2 When handling the equipment, care should be taken with corners and edges and that the weight distribution within the unit is considered. Lifting gear such as slings or ropes must be arranged so as not to bear on the casing.

3.3 Equipment stored on site prior to installation should be protected from the weather and steps taken to prevent ingress of contaminants.

### 4.0 OPERATIONAL LIMITS

4.1 It is important that the specified operational limits for the equipment are adhered to e.g. operational air temperature, air borne contaminants and unit orientation.

4.2 Where installation accessories are supplied with the specified equipment eg. wall mounting brackets. They are to be used to support the equipment only. Other system components must have separate provision for support.

4.3 Flanges and connection spigots are provided for the purpose of joining to duct work systems. They must not be used to support the ductwork.

4.4 In the event of RF interference the fan may change speed. This is normal and will have no adverse effect on the fan. The speed will return to normal once the interference has subsided.

### 5.0 INSTALLATION REQUIREMENTS

In addition to the particular requirements given for the individual product, the following general requirements should be noted.

- 5.1 Where access to any part of equipment which moves, or can become electrically live are not prevented by the equipment panels or by fixed installation detail (eg ducting), then guarding to the appropriate standard must be fitted.
- 5.2 The electrical installation of the equipment must comply with the requirements of the relevant local electrical safety regulations.
- 5.3 For EMC all control and sensor cables should not be placed within 50mm or on the same metal cable tray as 230V switched live, lighting or power cables and any cables not intended for use with this product.

### 6.0 COMMISSIONING REQUIREMENTS

6.1 General pre-commissioning checks relevant to safe operation consist of the following:

- Ensure that no foreign bodies are present within the fan or casing.
- Check electrical safety. e.g. Insulation and earthing.
- Check guarding of system.
- Check operation of Isolators/Controls.
- Check fastenings for security.

6.2 Other commissioning requirements are given in the relevant product documentation.

### 7.0 OPERATIONAL REQUIREMENTS

- 7.1 Equipment access panels must be in place at all times during operation of the unit, and must be secured with the original fastenings.
- 7.2 If failure of the equipment occurs or is suspected then it should be taken out of service until a competent person can effect repair or examination. (Note that certain ranges of equipment are designed to detect and compensate for fan failure).

### 8.0 MAINTENANCE REQUIREMENTS

- 8.1 Specific maintenance requirements are given in the relevant product documentation.
- 8.2 It is important that the correct tools are used for the various tasks required.
- 8.3 If the access panels are to be removed for any reason the electrical supply to the unit must be isolated.
- 8.4 A minimum period of two minutes should be allowed after electrical disconnection before access panels are removed. This will allow the impeller to come to rest.  
**NB: Care should still be taken however since airflow generated at some other point in the system can cause the impeller to "windmill" even when power is not present.**
- 8.5 Care should be taken when removing and storing access panels in windy conditions.



Western Industrial Estate  
Caerphilly United Kingdom  
CF83 1NA  
T: 029 2085 8200  
F: 029 2085 8300  
E: [ahu@nuaire.co.uk](mailto:ahu@nuaire.co.uk)  
W: [www.nuaire.co.uk](http://www.nuaire.co.uk)

Technical or commercial considerations may, from time to time, make it necessary to alter the design, performance and dimensions of equipment and the right is reserved to make such changes without prior notice.