



MRXBOX95-WALL

Mechanical Ventilation Unit with Heat Recovery for Wall Mounting

Installation and Maintenance

1.0 Introduction

IMPORTANT

Unit must not be switched off during normal operation, the product is designed to run continuously.

MRXBOX95-WALL is designed to provide mechanical supply and extract ventilation with heat recovery.

The unit is fitted with two independent fans. Each fan has full speed control for background and boost ventilation rates as well as a run-on timer facility. To recover heat from the extract air the heat exchanger block is utilised. This heat exchanger can recover up to 95% of the normally wasted heat.

Figure 1. Airflow through unit.

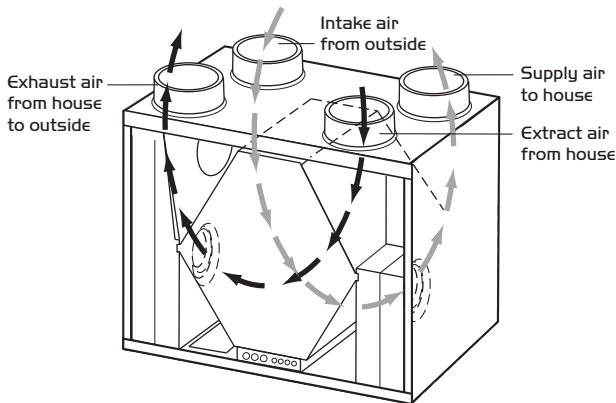

2.0 Installation

Installation must be carried out by competent personnel in accordance with the appropriate authority and conforming to all statutory governing regulations.

All mains wiring must be in accordance with the current I.E.E. Regulations, or the appropriate standards. Ensure that the mains supply (Voltage, Frequency and Phase) complies with the rating label.

Please note a clear working space is required around the installed unit to allow the cover to be removed and provide sufficient access for maintenance such as filter change.

The fan must be installed indoors, on a wall away from direct sources of frost, heat, water spray or moisture generation. For a vibration-free result the unit must be mounted to a solid wall.

The unit is designed for wall mounting only.

- One part of the mounting bracket should be offered up to the wall, ensuring it's located horizontally. Mark the fixing points through the pre drilled holes in the bracket and install with screws (by others), ensuring the interlock side is at the top (fig. 2).
- Fix the remaining part of the bracket to the unit using the M6 screws ensuring the interlock side is at the bottom (fig. 3).
- Install the unit on the wall by ensuring the bracket on the unit interlocks over the wall mounted bracket (fig. 4).

Figure 2. Fixing the mounting bracket to the wall.

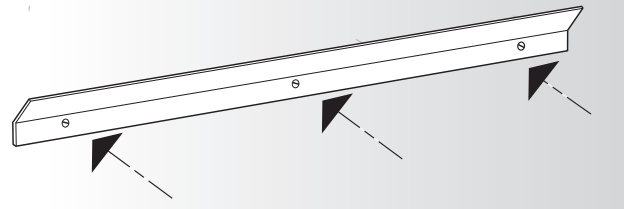

Figure 3. Fixing the mounting bracket to the rear of unit.

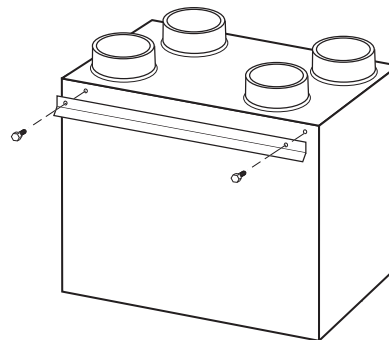
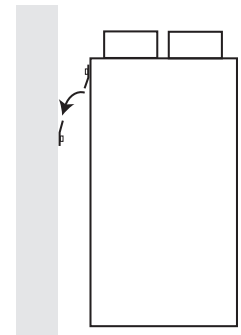

Figure 4. Mounting the unit on the wall mounted bracket.



2.1 Condensate Drain

- Remove the front cover from the unit.
- Insert the drain connector through the base of the unit from outside. The condensate must be discharged under a water level in a U-trap drainpipe or an alternative drain method which acts as an airlock.
- Ensure the drain connector forms a seal with the drain tray applying sealant if necessary. This condensate discharge connection is suitable for 21.5mm dia. overflow pipe. Solvent cement should be used to make the joint.
- Pour water into the drip tray to create an air trap.

Figure 5. Condensate pipe connection to unit and a typical example of a "U" trap drainpipe.

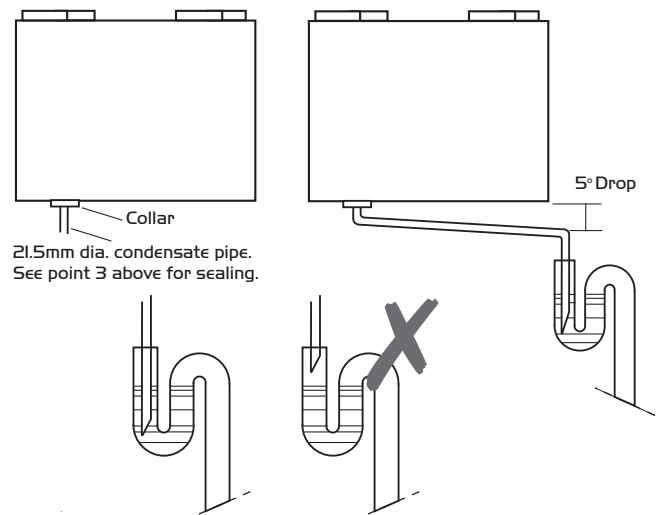

2.2 Extract/input areas

The unit is designed to extract air from all wet rooms e.g. bathroom, kitchen, en-suite, utility room (with sink). WC's do not need to be ventilated if openable windows are fitted.

Supply air should be to all habitable rooms e.g. bedrooms and lounge. Extract / input grilles should be adjustable valve types (not supplied).

2.3 Ducting

The use of flexible ducting must be kept to a minimum and should always be pulled taut.

To prevent condensation on the outside of the outside air inlet duct and the air outlet duct from the MRXBOX95-WALL, these ducts should be insulated.

Ducting must be installed in such a way that resistance to airflow is minimised.

A minimum distance of 200mm between the appliance and any bends in ductwork is recommended.

Ducting joints must be sealed with ducting tape and or silicone type sealant.

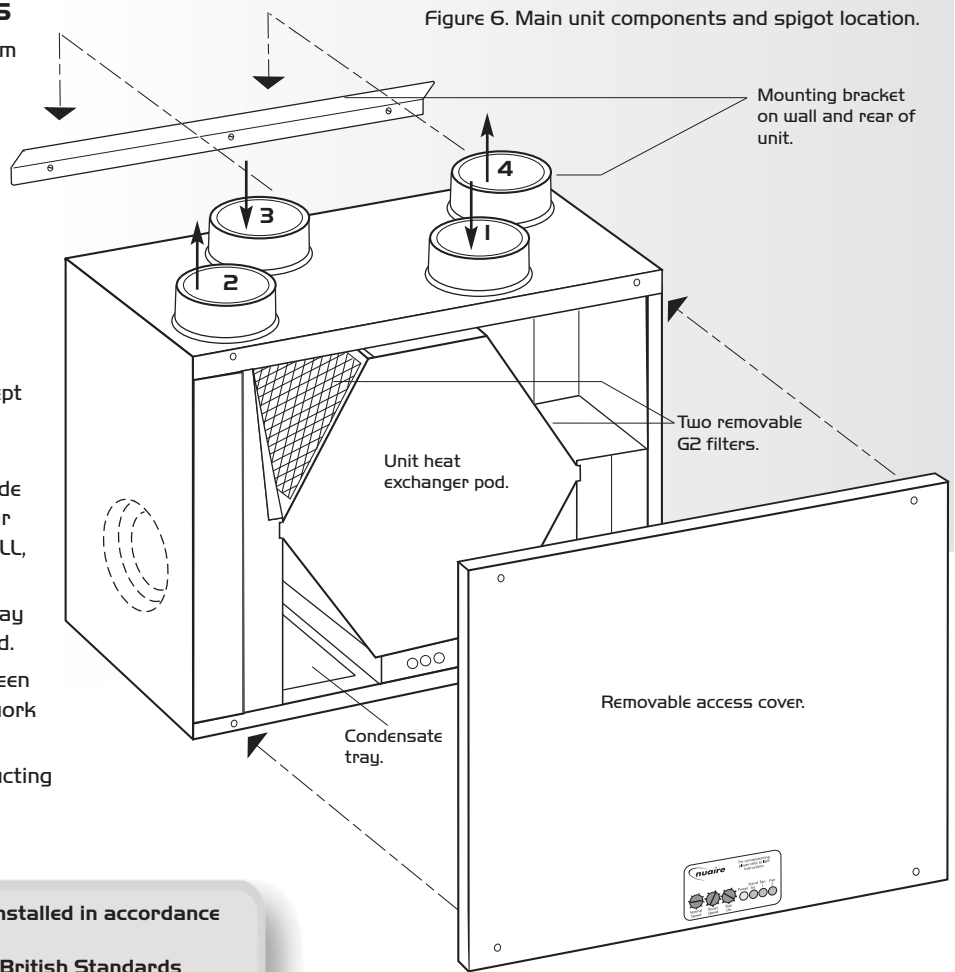

Figure 6. Main unit components and spigot location.

IMPORTANT

Any air intake terminal **MUST** be installed in accordance with the appropriate regulation. As a guide, the B55440 series of British Standards deals with this issue and currently states that an air intake must be at a minimum distance of 300mm from a gas boiler balanced flue. Installers are advised to be aware of the requirements of this standard when installing 'through the wall' supply air ducting. Similarly, supply and extract air grilles should be at least 300mm apart.

Spigot Location and Ducting references (see figure 6)

- Spigot 1.** 125mm dia. = extract air from dwelling.
- Spigot 2.** 125mm dia. = exhaust air to outside.
- Spigot 3.** 125mm dia. = intake air from outside.
- Spigot 4.** 125mm dia. = supply air to house.

3.0 Dimensions

VIEW FROM FRONT WITH COVER REMOVED

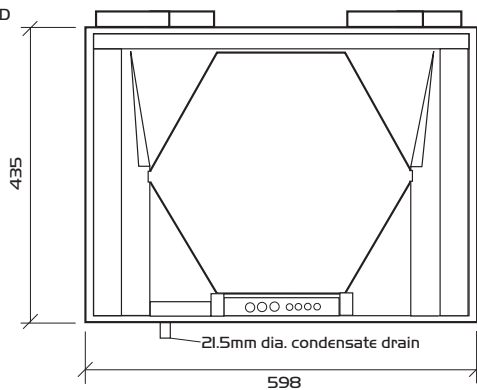

SIDE VIEW

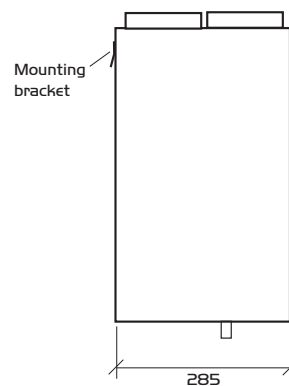

VIEW FROM TOP

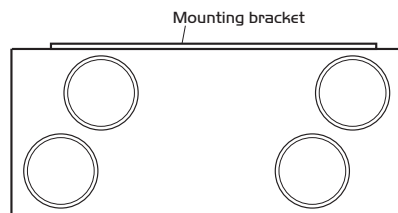

4.0 Electrical Connection

IMPORTANT

For good EMC engineering practice, any sensor cables or switched live cables should not be placed within 50mm of other cables or on the same metal cable tray as other cables.

Please note: the electrical connection of the unit must be carried out by a qualified electrician.

Electrical details:-

Voltage: 240V lph 50Hz

Consumption: 75W (max) 0.6 amps

Fuse rating: 3 Amp

NOTE This unit must be earthed

Figure 7a. Power supply PCB.
230V in, 24V dc out.

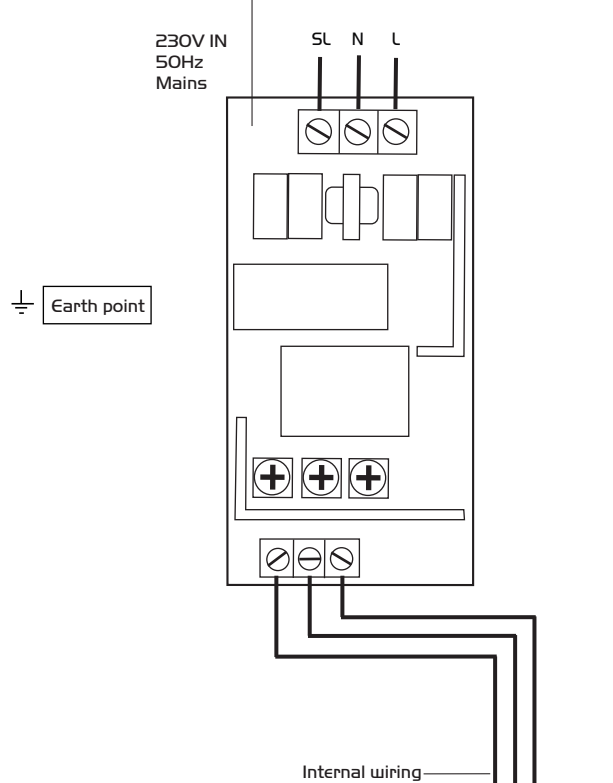

Figure 7b.

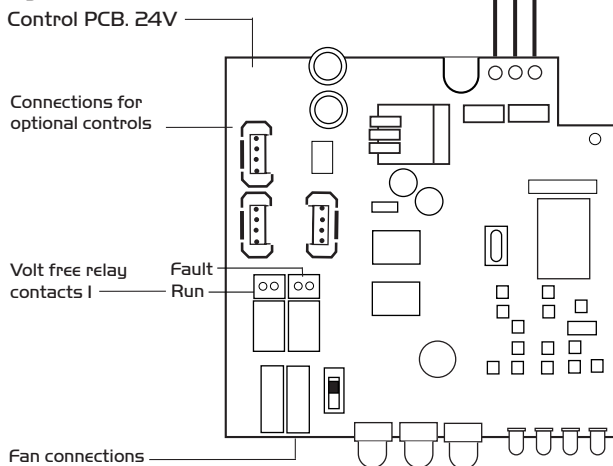

Figure 8.

Unit serving Kitchen and Bathroom

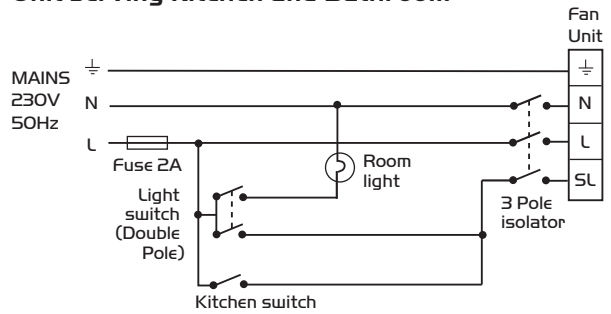
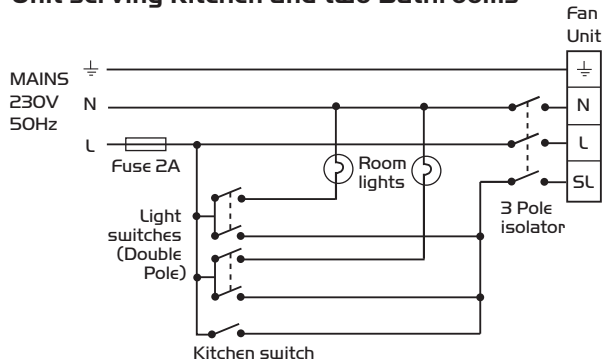

Figure 9.

Unit serving Kitchen and two Bathrooms



Electrical connection cont.

Optional Connections

Ecosmart control (see figure 7b)

(a) J11/J12/J13

The IDC plug-in connectors are provided for the connection of compatible sensors.

NOTE: Do not run the data cable in the same conduit as the mains cable and leave a 50mm separation with any power cables.

(b) Volt Free Relay Contacts

Note that the volt free contacts are not fused. If these are used to power any external equipment, the installer must provide adequate fusing or other protections. These contacts are rated at 5A resistive, 0.5A inductive.

Run connections (J5) - These contacts are closed when the fan is running.

Fault connections (J7) - No fault = the contacts are closed.

Fault = the contacts are opened (this includes no power supply at the unit).

(c) Data Cable installation

A 4-core data cable is used to connect devices such as sensors to the fan and for interconnecting multiple fan units.

Do not run data cable in the same conduit as the mains cables and ensure there is a 50mm separation between the data cable and other cables. The maximum cable run between any two devices is 300m when it is installed in accordance with the instructions.

Please note that the total data cable length used in any system must be less than 1000m. Keep the number of cable joints to a minimum to ensure the best data transmission efficiency between devices.

LED Indication

PWR GREEN: Power on and OK,

RED: Standby LED on when fan is not running. As the unit runs continuously this LED should be off. If it is illuminated locate the trickle switch and change its position.

Fan 1 GREEN: Fan 1 is running, **RED:** Fan 1 faulty.

Fan 2 GREEN: Fan 2 is running, **RED:** Fan 2 faulty.

5.0 Ancillaries

Passive Infra red detector	MRXBOX95-PIR
External Humidity sensor	MRXBOX95-HUM
Remote Fail Indicator	MRXBOX95-RFI

6.0 Commissioning

1. For the required airflow rates refer to the design specification for the property or refer to Building Regulations Part F.
2. The unit is supplied with control of both the normal airflow and boost airflow. (see figure below).
3. Commissioning should be carried out using a moving vane anemometer in conjunction with a hood.
4. Once commissioned the house owner / tenant should be informed that the unit should not be adjusted as it will have a detrimental effect on the indoor air quality and could result in condensation and mould growth.

Figure 10. Detail of unit control on front panel.

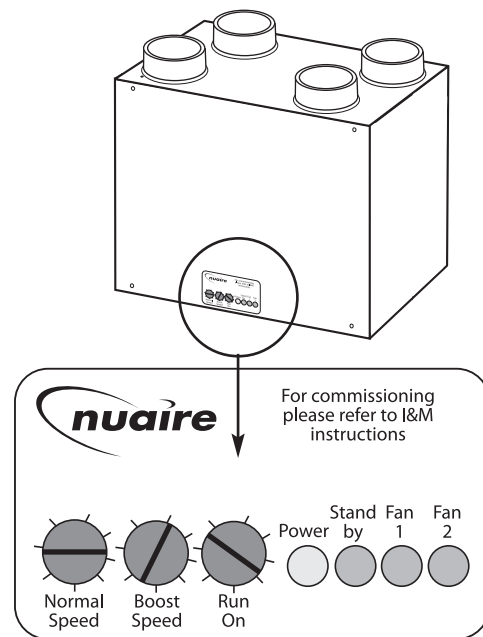

7.0 Maintenance/Cleaning

IMPORTANT

Isolation - Before commencing work make sure that the unit, switched live and Nuaire control are electrically isolated from the mains supply and switched live supply.

1. We recommend that the two G2 filters are inspected after 6 months, and replaced every 12 to 18 months.

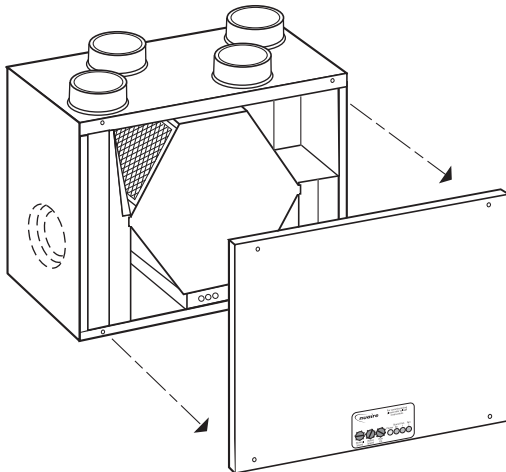

2. Remove the front cover and slide out the filters which are fitted either side of the heat exchanger, return or replace them as necessary.

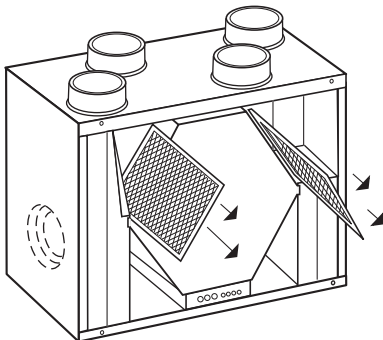

3. Inspect the heat exchanger every 5 years. Generally check for damage and security of components. Refit cover.

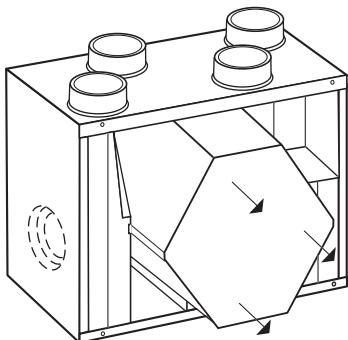

4. Inspecting motors. Motors can be accessed through removal side panels.

8.0 Replacement of Parts

Should any component need replacing Nuaire keep extensive stocks for quick delivery. Ensure that the unit is electrically isolated, before carrying out any work.

When ordering spare parts, please quote the serial number of the unit and the ARC number of the purchase if possible. (This information will be available on the fan label).

9.0 Warranty

The 5 year warranty starts from the day of delivery and includes parts and labour for the first year and parts only for the remaining 4 years. This warranty is conditional on planned maintenance being undertaken.

10.0 Service Enquiries

Nuaire can assist you in all aspects of service. Our Technical Support department will be happy to provide any assistance required.

Telephone 029 2085 8400

Technical or commercial considerations may, from time to time, make it necessary to alter the design, performance and dimensions of equipment and the right is reserved to make such changes without prior notice.

DECLARATION OF INCORPORATION AND INFORMATION FOR SAFE INSTALLATION, OPERATION AND MAINTENANCE

We declare that the machinery named below is intended to be assembled with other components to constitute a system of machinery. All parts except for moving parts requiring the correct installation of safety guards comply with the essential requirements of the Machinery Directive. The machinery shall not be put into service until the system has been declared to be in conformity with the provisions of the EC Machinery Directive.

Signature of manufacture representatives:

Name:	Position:	Date:
1) C. Biggs	Technical Director	29. 12. 09
2) A. Jones	Manufacturing Director	29. 12. 09

Designation of machinery: **MRXBOX95-WALL**
 Machinery Types: Mechanical Ventilation with Heat Recovery
 Relevant EC Council Directives: 2006/42/EC (Machinery Directive)
 Applied Harmonised Standards: BS EN ISO 12100-1, BS EN ISO 12100-2, EN60204-1, BS EN ISO 9001, BS EN ISO 13857
 Applied National Standards: BS848 Parts 1, 2.2 and 5

Note: All standards used were current and valid at the date of signature.

CE DECLARATION OF CONFORMITY

We declare that the machine named below conforms to the requirements of EC Council Directives relating to Electromagnetic Compatibility and Safety of Electrical Equipment.

Signature of manufacture representatives:

Name:	Position:	Date:
1) C. Biggs	Technical Director	29. 12. 09
2) A. Jones	Manufacturing Director	29. 12. 09

Designation of machinery: **MRXBOX95-WALL**
 I & M Serial No.: 671437
 Machinery Types: Mechanical Ventilation with Heat Recovery
 Relevant EC Council Directives: 2004/108/EC (EMC), 2006/95/EC (Low Voltage Directive)
 Applied Harmonised Standards: EN55014-1, EN55014-2, EN61000-3-2, EN61000-3-3, EN60335-2-80
 Basis of Self Attestation: Quality Assurance to BS EN ISO 9001 BSI Registered Firm Certificate No. FM 149

Nuaire Ltd,
 Western Industrial Estate,
 Caerphilly CF83 1NA.

Note: All standards used were current and valid at the date of signature.

INFORMATION FOR SAFE INSTALLATION, OPERATION AND MAINTENANCE OF NUAIRE VENTILATION EQUIPMENT

To comply with EC Council Directives 2006/42/EC Machinery Directive and 2004/108/EC (EMC).

To be read in conjunction with the relevant Product Documentation (see 2.1)

1.0 GENERAL

1.1 The equipment referred to in this Declaration of Incorporation is supplied by Nuaire to be assembled into a ventilation system which may or may not include additional components.

The entire system must be considered for safety purposes and it is the responsibility of the installer to ensure that all of the equipment is installed in compliance with the manufacturers recommendations and with due regard to current legislation and codes of practice.

2.0 INFORMATION SUPPLIED WITH THE EQUIPMENT

2.1 Each item of equipment is supplied with a set of documentation which provides the information required for the safe installation and maintenance of the equipment. This may be in the form of a Data sheet and/or Installation and Maintenance instruction.

2.2 Each unit has a rating plate attached to its outer casing. The rating plate provides essential data relating to the equipment such as serial number, unit code and electrical data. Any further data that may be required will be found in the documentation. If any item is unclear or more information is required, contact Nuaire.

2.3 Where warning labels or notices are attached to the unit the instructions given must be adhered to.

3.0 TRANSPORTATION, HANDLING AND STORAGE

3.1 Care must be taken at all times to prevent damage to the equipment. Note that shock to the unit may result in the balance of the impeller being affected.

3.2 When handling the equipment, care should be taken with corners and edges and that the weight distribution within the unit is considered. Lifting gear such as slings or ropes must be arranged so as not to bear on the casing.

3.3 Equipment stored on site prior to installation should be protected from the weather and steps taken to prevent ingress of contaminants.

4.0 OPERATIONAL LIMITS

4.1 It is important that the specified operational limits for the equipment are adhered to e.g. operational air temperature, air borne contaminants and unit orientation.

4.2 Where installation accessories are supplied with the specified equipment eg. wall mounting brackets. They are to be used to support the equipment only. Other system components must have separate provision for support.

4.3 Flanges and connection spigots are provided for the purpose of joining to duct work systems. They must not be used to support the ductwork.

4.4 In the event of RF interference the fan may change speed. This is normal and will have no adverse effect on the fan. The speed will return to normal once the interference has subsided.

5.0 INSTALLATION REQUIREMENTS

In addition to the particular requirements given for the individual product, the following general requirements should be noted.

5.1 Where access to any part of equipment which moves, or can become electrically live are not prevented by the equipment panels or by fixed installation detail (eg ducting), then guarding to the appropriate standard must be fitted.

5.2 The electrical installation of the equipment must comply with the requirements of the relevant local electrical safety regulations.

5.3 For EMC all control and sensor cables should not be placed within 50mm or on the same metal cable tray as 230V switched live, lighting or power cables and any cables not intended for use with this product.

6.0 COMMISSIONING REQUIREMENTS

6.1 General pre-commissioning checks relevant to safe operation consist of the following:

Ensure that no foreign bodies are present within the fan or casing.

Check electrical safety. e.g. Insulation and earthing.

Check guarding of system.

Check operation of Isolators/Controls.

Check fastenings for security.

6.2 Other commissioning requirements are given in the relevant product documentation.

7.0 OPERATIONAL REQUIREMENTS

7.1 Equipment access panels must be in place at all times during operation of the unit, and must be secured with the original fastenings.

7.2 If failure of the equipment occurs or is suspected then it should be taken out of service until a competent person can effect repair or examination. (Note that certain ranges of equipment are designed to detect and compensate for fan failure).

8.0 MAINTENANCE REQUIREMENTS

8.1 Specific maintenance requirements are given in the relevant product documentation.

8.2 It is important that the correct tools are used for the various tasks required.

8.3 If the access panels are to be removed for any reason the electrical supply to the unit must be isolated.

8.4 A minimum period of two minutes should be allowed after electrical disconnection before access panels are removed. This will allow the impeller to come to rest.

NB: Care should still be taken however since airflow generated at some other point in the system can cause the impeller to "windmill" even when power is not present.

8.5 Care should be taken when removing and storing access panels in windy conditions.