



Drimaster365

Low Energy Positive Input Ventilation Unit

Installation and Maintenance Details

CE The EMC Directive 2014/30/EU
The Low Voltage directive 2014/35/EU

1.0 Important notes to installers

The successful operation of this unit depends entirely upon installation and ongoing maintenance being carried out in accordance with these instructions.

Please read this guide in its entirety before installation and then repeat the exercise step by step to ensure satisfactory completion.

Suitably qualified persons may achieve installation of the unit, however the provision of the electrical supply and the connection of the unit to the mains supply should only be carried out by a qualified electrician.

The unit can be installed in a home with a "cold roof" construction.

Note: If a floor is higher than 4.5m the requirements in sections 5.2 and 10.2 must be followed.

Note: 3 storey properties must be fitted with an aluminium diffuser - see section 5.2.

2.0 General description

The unit is a unique low energy Positive Input Ventilation (LEPIV) unit. Unlike conventional LEPIV units which only draw in external air via the loft in a "cold roof", the unit is capable of drawing in external air from a roof location via an inlet spigot fitted with a low energy open/close damper.

It is not necessary for the home owner to program or operate the unit in any way, as the 365 is totally automatic.

The unit intelligently decides where the fresh air will be supplied from.

If the loft temperature is below 24°C then the unit will take fresh air from the loft.

If the loft temperature is above 24°C then cool fresh air will be taken from outside the dwelling.

If the loft temperature is 19°C to 24°C and the house is cooler than this, then the unit goes into heat recovery mode. The unit will increase in speed and supply more air to the property.

The unit can be boosted to obtain maximum ventilation by the operation of a boost switch.

Figure 1. General view of unit installed on roof joists in a loft.

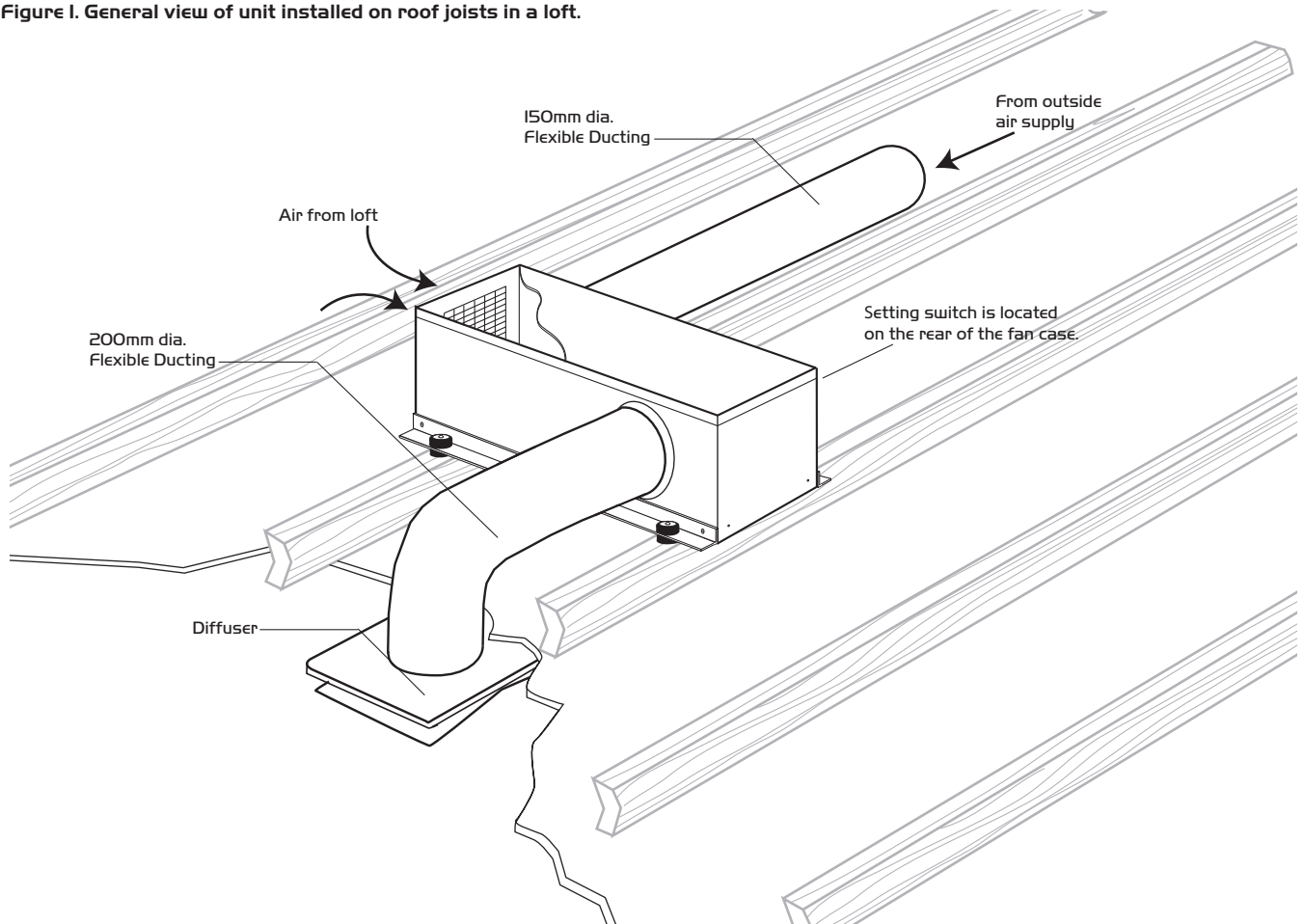

3.0 Loft inspection

Check to ensure that the loft has adequate ventilation. Look for ridge vents, tile vents, eaves vents and continuous air gaps etc. making sure none are blocked. In older properties these vents may not be provided, however there should be enough "leakage" to accommodate the requirements of the unit.

A useful way of checking such lofts is to close the hatch, switch off the lights and look for daylight penetration. If daylight is visible, it is reasonable to assume that the loft has sufficient ventilation.

There may be occasions where a loft is so well sealed that additional ventilation may have to be provided by the owner/occupier or the unit installer.

This will not only assist the operation of the unit, but will help prevent possible expensive structural damage caused by inadequate air movement in the loft.

It should be noted that there cannot be too much ventilation into the loft.

Additional checks should be carried out as follows:

Ensure that all water tanks are covered and sealed.

Check that all water pipes are lagged.

Ensure that any extract fans are discharging to outside and not into the loft.

Check that the loft hatch is tightly sealed.

Ensure all holes in the ceilings are sealed i.e. ceiling light fittings etc.

A visual inspection of flues or chimneys for leakage in the loft should be carried out by the installer.

If leakage points are found, or if there are any doubts, then the installer should advise the house owner/provider and seek instruction from them before continuing with the installation.

4.0 Siting the Diffuser

The diffuser has a unique air throw pattern and it is essential that it is located correctly in the central hallway in single storey properties or in the ceiling of the top floor landing on 2 or more storey dwellings. As can be seen in fig. 2 the diffuser discharges air evenly from all four sides along the underside of the ceiling.

Figure 2. Diffuser (viewed from below).

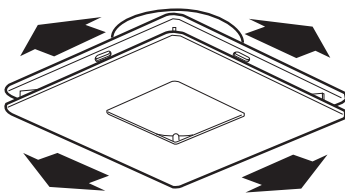

from four sides

Note: The positioning of the diffuser should be in strict accordance with the table shown below to ensure correct operation:-

Speed Setting	Minimum distance of diffuser from wall
1	100mm
2	155mm
3	400mm
4	625mm
5	850mm
6	1000mm

Note: SMOKE ALARMS

It is also important to ensure that the diffuser is NOT placed within 1 metre of a smoke alarm.

If the diffuser cannot be repositioned, **two sides of the diffuser must be closed off** using the foam strips supplied to encourage the air through the remaining open sides that faces at least 1.5 metres of unobstructed area away from the smoke alarm sensor.

Figure 3. Fitting the 2 foam strips.

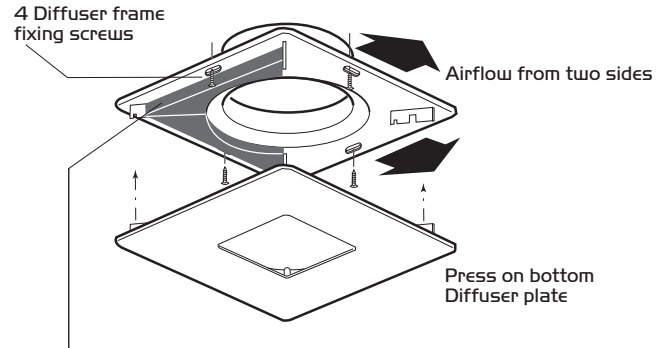

2 Foam strips (supplied) fit on any of the diffuser sides to guide airflow away from a smoke detector and/or obstructions as required.

5.0 Fitting the Diffuser

5.1 Plastic Type

Cut a circular hole 225mm diameter in the ceiling between two convenient joists. Position the diffuser frame and secure it to the underside of the ceiling with the 1 1/2" x 8 csk. hd. screws and plugs provided.

Attach the diffuser plate to the frame using the four built in press on clips provided.

Foam strips should also be used as required when this method of installing the diffuser is used.

5.2 Painted aluminium type c/w intumescent fireblock for 3 storey properties

Cut a 200mm hole in ceiling and align the top portion of unit (A) above the ceiling over the hole.

Position the central ceiling plate (B) on the ceiling in the room ensuring the the central hole is aligned with the hole in the ceiling. Use the 4 MS X 35mm screws to fix (B) to (A) through the 4 studs positioned on the upper side of (B).

Screw bottom part of the unit (C) to the the ceiling plate (B) through the plastic spacers and into the 2 studs positioned on the upper side of (A).

Figure 4.

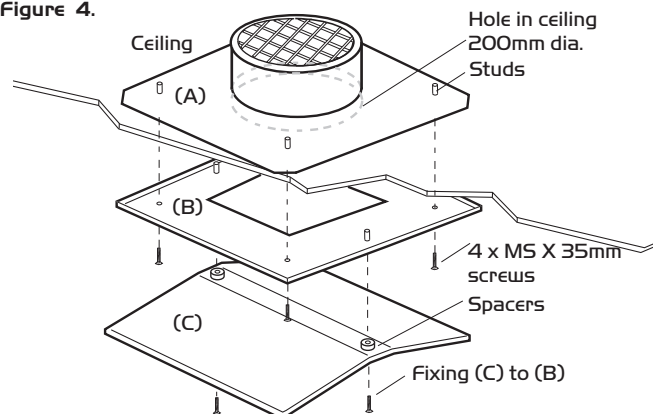

Note: Due to the higher air resistance of the fireblock, the speed of the unit should be increased by one increment for the particular property.

6.0 The Remote Sensor

Drimaster365 units are supplied with 15 metres of 2 core cable pre wired and ready to connect to the Remote Sensor (figure 5). The Remote Sensor is used in conjunction with the units internal sensor to allow the system to operate in "Heat Recovery Mode".

Figure 5. Remote Temperature Sensor.

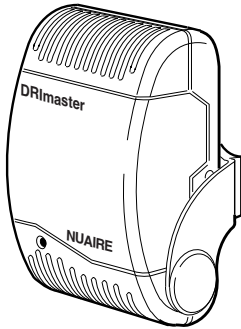

The sensor is fitted with an LED indicator which is capable of providing various status information if required.

As supplied the LED provides only the default setting of flashing RED after 5 years from commissioning to indicate that the filters need cleaning or replacement and permanent RED to indicate a failure.

Two other indications are available by closing the sprung gate latch (see figure 11). These are: GREEN to indicate when the system is in 'Heat Recovery Mode' and AMBER which indicates normal operation.

If it is desired to disable the LED function completely the LED itself may be 'bent' over to one side in order to render it 'blind' to the user.

7.0 Siting the Remote Sensor

The Remote Temperature Sensor incorporates a clip-in fixing bracket which can be removed for easy fitting to a suitable surface. (figure 8).

- Select a suitable location for the sensor e.g. close to ceiling height in a bedroom or hallway BUT NOT WITHIN 3 METRES of the diffuser.
- Arrange the connecting cable in position. Leave approx. 75mm of the cable free at the mounting point to ease the connection of the cable. (figure 6).
- Carefully separate the sensor from the fixing bracket using a small screwdriver (figure 7).
- Fix the bracket to the wall and arrange the end of the cable to fall through the slot cut in the bracket (figure 8).
- Carefully separate the two sensor halves to reveal the wiring connection terminals. (figure 9).
- Feed the twin cable through the cut out rear half and connect the two wires to the terminals.
- Reassemble the sensor body halves.
- Clip the sensor body in the fixing bracket arms and adjust the sensor body to the desired position. (figure 10).

The remote sensor is connected to the circuit board via the supplied 2 core cable and into the connector labelled 'Remote Sensor' on the circuit board.

Figure 6.

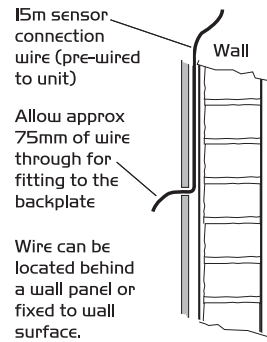

Figure 7.

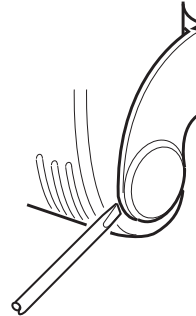

Figure 8.

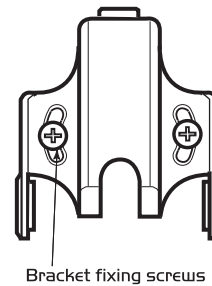

Figure 9.

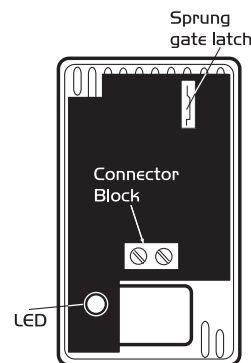
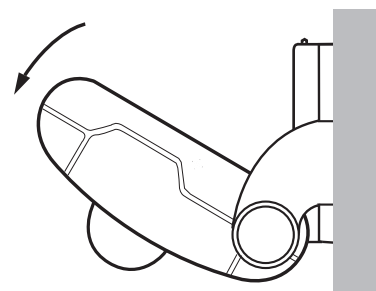
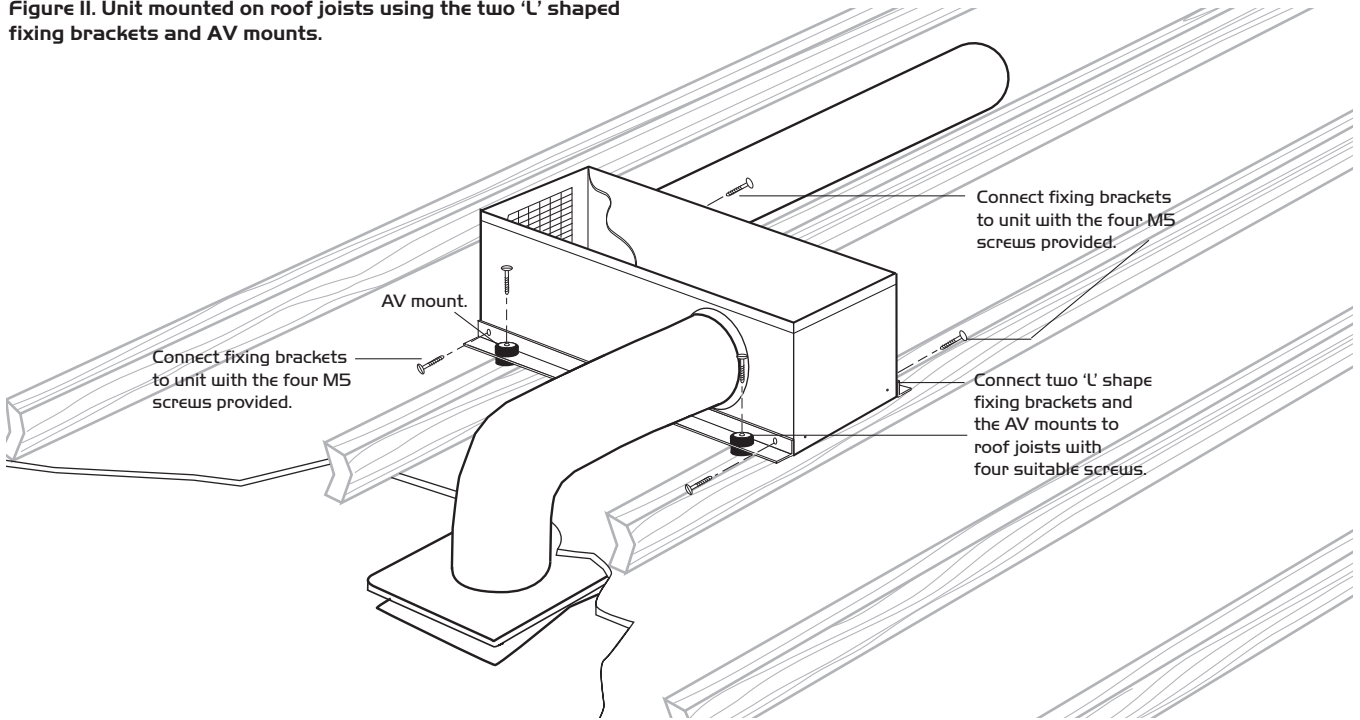

Figure 10.



8.0 Fitting the Unit

Figure II. Unit mounted on roof joists using the two 'U' shaped fixing brackets and AV mounts.



Fitting the unit

Connect the two 'U' shape fixing brackets to the long sides of the unit with the M5 screws (provided) then lower the unit with the "L" shape fixing brackets attached to the unit onto the joists (see Figure II). Mark four holes through the brackets so that the holes will be centrally positioned over a joist.

Locate anti-vibration mounts (supplied) above and below each bracket fixing point hole and, using 4 suitable screws (not provided) and washers, fix the unit to the joists.

Do not overtighten the fixings.

Fitting the unit (optional configuration)

Using a similar procedure the two 'U' shape fixing brackets can also be mounted on the short sides of the Drimaster365 unit if an alternative mounting position is required (see figure IIa below).

Figure IIa. Optional mounting on roof joists using the two 'U' shaped fixing brackets and AV mounts.

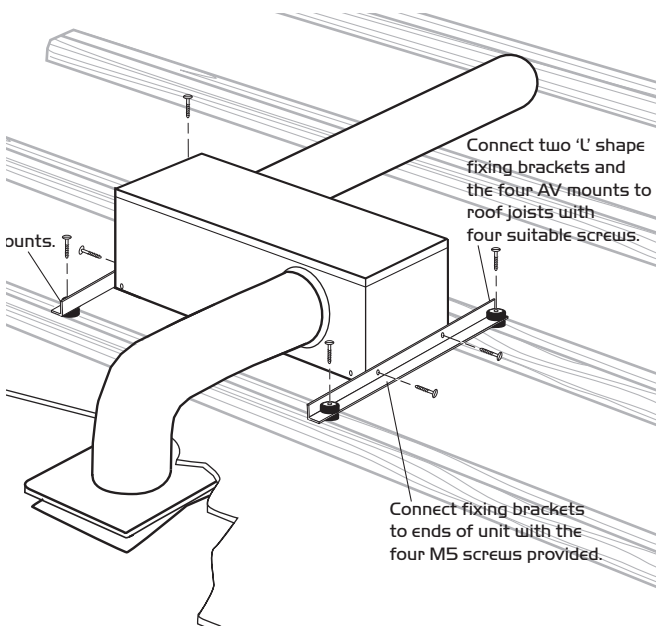

9.0 Main fan units air inlet and associated sensor connections

As explained previously the unit is capable of drawing in external air from different roof locations via an air inlet spigot.

Air inlet locations are as follows:

- A. The soffit through a grille and ducting, supplied by others. (see 9.1).
- B. Wall grille and ducting, supplied by others. (see 9.2).

The following installation materials, not supplied with the unit, can be purchased separately direct from Nuair.

Tel: 08705 002555.

Fax: 08705 002666. E-mail: info@nuaire.co.uk

Part No	Description
DRI365-SOFFITKIT (see 9.1)	
775229	128mm x 260mm soffit grille ***
PVC933WH	3m length of 222mm x 90mm flexible PVC ducting for use on soffit inlets.
FLDI150	5m length of 150mm dia insulated ducting.
RDCI50	150mm duct connector for connecting 222 x 90 flexible duct to 150mm duct.
777483	2m length insulated flexible ducting.
DT33	qty 8 dynotie zip ties, used for connecting ducting to spigots.
DRI365-WALLKIT (see 9.2)	
FLDI150	5m length of 150mm dia. Insulated ducting.
777483	2m length insulated flexible ducting.
PVC604WH	Outlet grille.
PVC130-6WH	150mm telescopic pipe.
DT33	qty 8 dynotie zip ties, used for connecting ducting to spigots.

9.1 Via the soffit through a grille and ducting supplied by others

Figure 12.

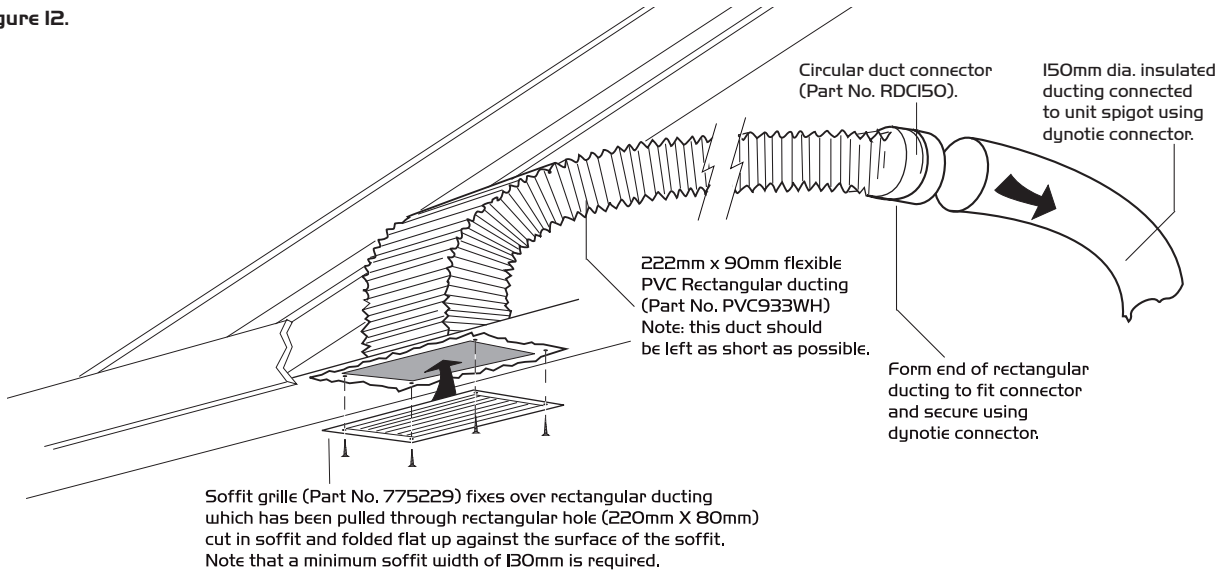

9.2 Via a wall grille and ducting supplied by others

Figure 13.

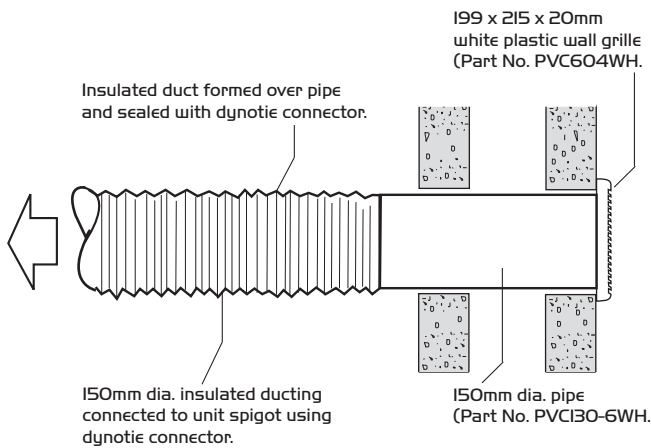

IMPORTANT

Any air intake terminal **MUST** be installed in accordance with the appropriate regulation.

As a guide, the BS5440 series of British Standards deals with this issue and currently states that an air intake must be at a minimum distance of 300mm from a gas boiler balanced flue. Installers are advised to be aware of the requirements of this standard when installing 'through the wall' supply air ducting.

Similarly, supply and extract air grilles should be at least 300mm apart.

10.0 Electrical Connection

Please note: the electrical connection of the unit must be carried out by a qualified electrician.

Electrical details:-

Voltage: 240V Iph 50Hz

Consumption: 2W (min) 24W (max)

Fuse rating: 3 Amp

NOTE This unit must be earthed

The three core cable from the mains power supply should be connected to a fixed wiring installation, via a fused isolator, in accordance with current IEE wiring regulations.

IMPORTANT

For good EMC engineering practice, any sensor cables or switched live cables should not be placed within 50mm of other cables or on the same metal cable tray as other cables.

10.1 Additional electrical connection by installer

When removing the lid for any reason disconnect the 230V power supply.

Before the unit is operational, additional wiring is necessary.

1. A 230V single phase supply is required to be connected to the circuit board within the unit, (see fig. I4) via the electrical gland (supplied) on the side of the Drimaster365. (see fig. I5).
2. A boost switch (supplied) is to be connected to the circuit board with two core cable (supplied), via the grommet at the front of the unit. (see figs. I4 and I5).
3. The remote sensor (supplied) is to be connected to the circuit board with two core cable (supplied), via the grommet at the front of the unit. (see figs. I4 and I5).

Figure I4. Unit circuit board.

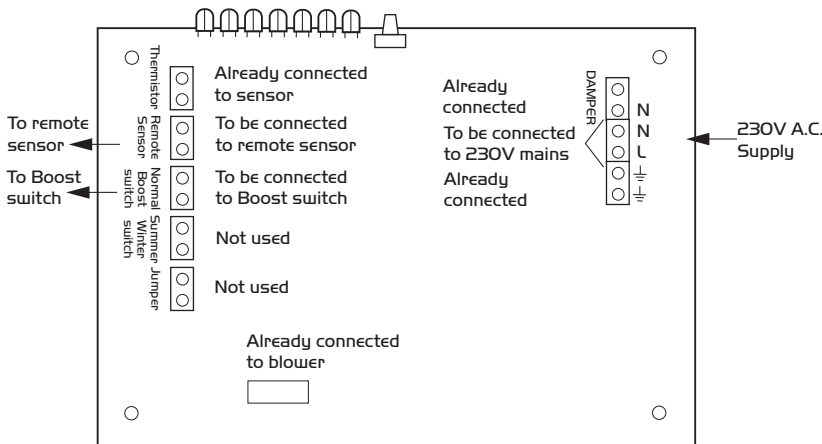
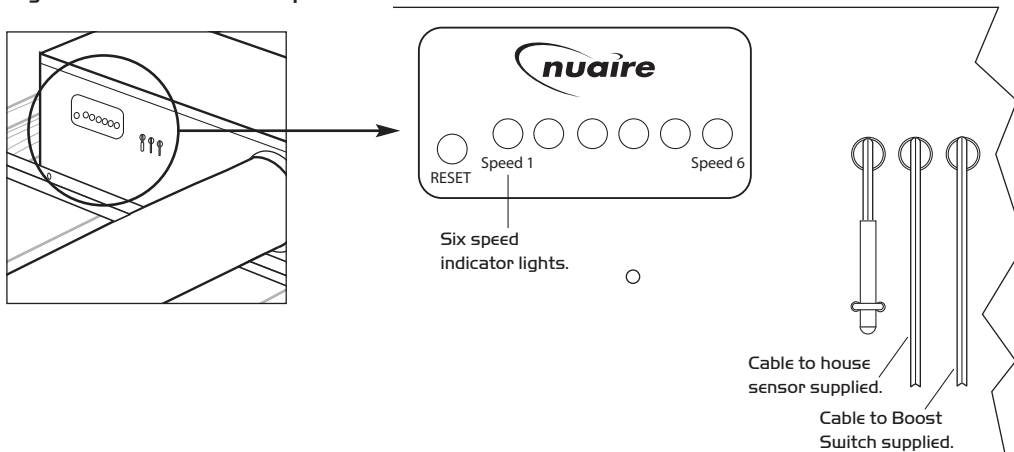

Figure I5. Detail of unit rear panel.



10.2 Smoke/Carbon monoxide alarm automatic shut down

If the unit is required to switch off in the event of smoke/CO detection, alarms are available with separate relay bases from companies such as:

Dicon Safety products – www.diconsafety.co.uk

Aico Ltd – www.aico.co.uk

Figure I6. Typical wiring (refer to manufacturers own specific instructions).

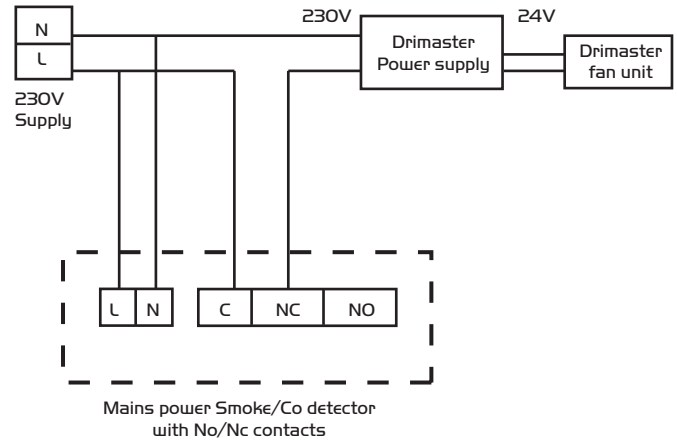

11.0 Airflow Adjustment on fan unit

The unit has six air volume (speed) settings. The setting switch is located on the rear of the fan case.

Figure I5 shows the LED's that, when illuminated, indicate the corresponding air volume for the unit.

For example, a one bedroom, one person bungalow recommended setting would be speed one:

A five bedroom, seven person detached house recommended setting would be six. The installer would advise this on install.

On initial set up when power is connected the first three LED's will flash randomly for approximately 2 minutes and will then set at its default factory setting (speed two). To select another speed setting simply press the reset button until the required setting is selected.

A boost switch (supplied) is to be connected to the circuit board within the unit (see fig. I4) with two core cable (supplied). This two core cable is to pass through the unit as shown in fig. I5.

The switch is to be located within the home for the householder to be able to boost the unit if required.

The unit air volume can be manually boosted to maximum speed by operation of the boost switch. This is to obtain maximum ventilation from the unit should the householder require it.

12.0 Dimensions (in mm)

Figure 17. Diffuser.

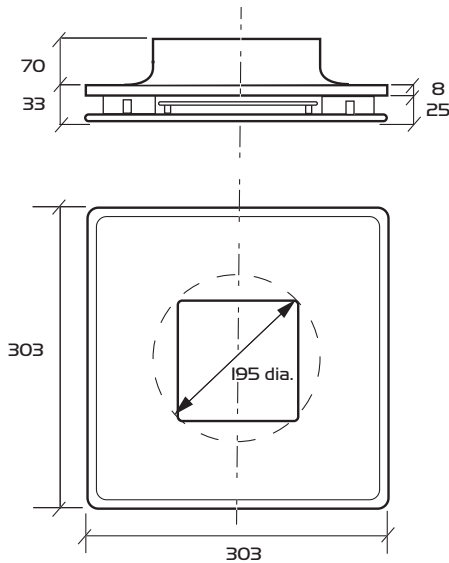
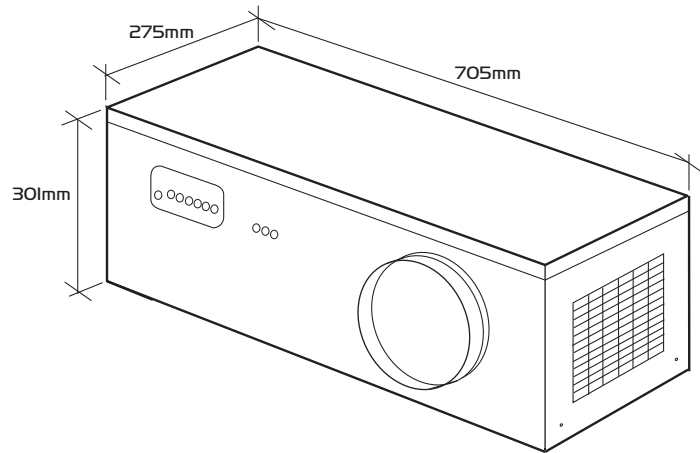

Figure 18. Drimaster365 unit.



13.0 Maintenance

The unit does not require any maintenance other than a filter change and a check of electrical connections every 5 years.

New filters can be purchased direct from Nuair using the following code: 777389 (5 year filter).

Dust can occasionally accumulate through static, on the diffuser and the adjacent ceiling. This can be removed if required by vacuuming.

Note: A clear distance of 500mm should be available above the unit to allow access for maintenance.

13.1 Filter Change

Once every 5 years the filters need changing.

- a) Make sure the power to the unit is off.
- b) Open the lid of the Air Handling Unit by removing the 5 screws which hold the lid on.
- c) Remove the filter.
- d) Replace the filter.
- e) Replace and secure the lid.

14.0 Warranty

The unit has a 5 year warranty starting from the day of delivery and includes parts and labour for the first year. The remaining 4 years covers parts only.

This warranty is void if the equipment is modified without authorisation, is incorrectly applied, misused, disassembled, or not installed, commissioned and maintained in accordance with the details contained in this manual and general good practice.

The product warranty applies to the UK mainland and in accordance with Clause 14 of our Conditions of Sale. Customers purchasing from outside of the UK should contact Nuair International Sales office for further details.

15.0 After Sales

For technical assistance or further product information, including spare parts and replacement components, please contact the After Sales Department.

Telephone 029 2085 8400



Technical or commercial considerations may, from time to time, make it necessary to alter the design, performance and dimensions of equipment and the right is reserved to make such changes without prior notice.

DECLARATION OF INCORPORATION AND INFORMATION FOR SAFE INSTALLATION, OPERATION AND MAINTENANCE

We declare that the machinery named below is intended to be assembled with other components to constitute a system of machinery. The machinery shall not be put into service until the system has been declared to be in conformity with the provisions of the EC Machinery Directive.

Designation of machinery: Drimaster365
Machinery Types: Low Energy Positive Input Ventilation
Relevant EC Council Directives: 2006/42/EC (Machinery Directive)
Applied Harmonised Standards: BS EN ISO 12100-1, BS EN ISO 12100-2, EN294, EN60204-1, BS EN ISO 9001
Applied National Standards: BS848 Parts One, Two and Five

Signature of manufacture representatives:

Name:	Position:	Date:
1) C. Biggs	 Technical Director	20. 07. 07
2) A. Jones	 Manufacturing Director	20. 07. 07

INFORMATION FOR SAFE INSTALLATION, OPERATION AND MAINTENANCE OF NUAIRE VENTILATION EQUIPMENT

To comply with EC Council Directives 2006/42/EC Machinery Directive and 2014/30/EU (EMC).

To be read in conjunction with the relevant Product Documentation (see 2.1)

1.0 GENERAL

1.1 The equipment referred to in this Declaration of Incorporation is supplied by Nuairé to be assembled into a ventilation system which may or may not include additional components.

The entire system must be considered for safety purposes and it is the responsibility of the installer to ensure that all of the equipment is installed in compliance with the manufacturers recommendations and with due regard to current legislation and codes of practice.

2.0 INFORMATION SUPPLIED WITH THE EQUIPMENT

- 2.1 Each item of equipment is supplied with a set of documentation which provides the information required for the safe installation and maintenance of the equipment. This may be in the form of a Data sheet and/or Installation and Maintenance instruction.
- 2.2 Each unit has a rating plate attached to its outer casing. The rating plate provides essential data relating to the equipment such as serial number, unit code and electrical data. Any further data that may be required will be found in the documentation. If any item is unclear or more information is required, contact Nuairé.
- 2.3 Where warning labels or notices are attached to the unit the instructions given must be adhered to.

3.0 TRANSPORTATION, HANDLING AND STORAGE

- 3.1 Care must be taken at all times to prevent damage to the equipment. Note that shock to the unit may result in the balance of the impeller being affected.
- 3.2 When handling the equipment, care should be taken with corners and edges and that the weight distribution within the unit is considered. Lifting gear such as slings or ropes must be arranged so as not to bear on the casing.
- 3.3 Equipment stored on site prior to installation should be protected from the weather and steps taken to prevent ingress of contaminants.

4.0 OPERATIONAL LIMITS

- 4.1 It is important that the specified operational limits for the equipment are adhered to e.g. operational air temperature, air borne contaminants and unit orientation.
- 4.2 Where installation accessories are supplied with the specified equipment eg. wall mounting brackets. They are to be used to support the equipment only. Other system components must have separate provision for support.
- 4.3 Flanges and connection spigots are provided for the purpose of joining to duct work systems. They must not be used to support the ductwork.
- 4.4 In the event of RF interference the fan may change speed. This is normal and will have no adverse effect on the fan. The speed will return to normal once the interference has subsided.

5.0 INSTALLATION REQUIREMENTS

In addition to the particular requirements given for the individual product, the following general requirements should be noted.

- 5.1 Where access to any part of equipment which moves, or can become electrically live are not prevented by the equipment panels or by fixed installation detail (eg ducting), then guarding to the appropriate standard must be fitted.
- 5.2 The electrical installation of the equipment must comply with the requirements of the relevant local electrical safety regulations.
- 5.3 For EMC all control and sensor cables should not be placed within 50mm or on the same metal cable tray as 230V switched live, lighting or power cables and any cables not intended for use with this product.

6.0 COMMISSIONING REQUIREMENTS

- 6.1 General pre-commissioning checks relevant to safe operation consist of the following:
 Ensure that no foreign bodies are present within the fan or casing.
 Check electrical safety. e.g. Insulation and earthing.
 Check guarding of system.
 Check operation of Isolators/Controls.
 Check fastenings for security.
- 6.2 Other commissioning requirements are given in the relevant product documentation.

7.0 OPERATIONAL REQUIREMENTS

- 7.1 Equipment access panels must be in place at all times during operation of the unit, and must be secured with the original fastenings.
- 7.2 If failure of the equipment occurs or is suspected then it should be taken out of service until a competent person can effect repair or examination. (Note that certain ranges of equipment are designed to detect and compensate for fan failure).

8.0 MAINTENANCE REQUIREMENTS

- 8.1 Specific maintenance requirements are given in the relevant product documentation.
- 8.2 It is important that the correct tools are used for the various tasks required.
- 8.3 If the access panels are to be removed for any reason the electrical supply to the unit must be isolated.
- 8.4 A minimum period of two minutes should be allowed after electrical disconnection before access panels are removed. This will allow the impeller to come to rest.
NB: Care should still be taken however since airflow generated at some other point in the system can cause the impeller to "windmill" even when power is not present.
- 8.5 Care should be taken when removing and storing access panels in windy conditions.