

ECOHEATEX-2

Heat Exchange Unit

Installation and Maintenance

1.0 Introduction

The unit consists of an extract fan, a cross-flow heat-exchange unit, a by-pass damper and an intelligent control system. It is designed to be used in conjunction with a Nuair Positive Input Ventilation unit (PIV) to form a supply and extract system with heat exchange.

The PIV unit may be a Drimaster, Drimaster 2000 or Sunwarm Tile 1 or 2. The unit may also be used with a Nuair Sunwarm system, where it would connect in place of the PIV unit.

Figure 1.

Extract from wet rooms.

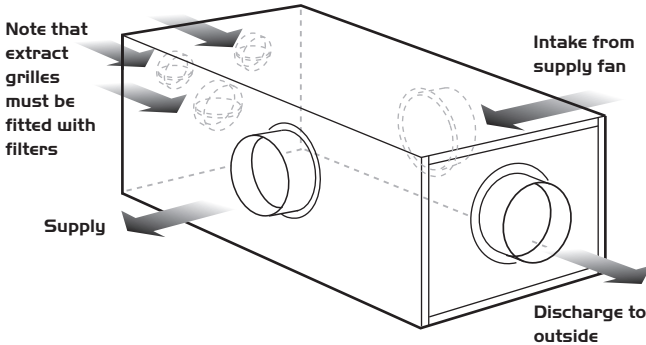

This manual will only provide the installation details of the heat exchange unit. Please refer to the relevant manual for installation details of the relevant PIV unit.

Drimaster Leaflet number 671104

Drimaster 2000 Leaflet number 671109

Sunwarm Tile 1 or 2 Leaflet number 671380

The bypass damper will open (i.e. no heat exchange will take place) when the following conditions are met.

The supply air inlet temperature is hotter than the extract air inlet temperature and the user control is demanding hot supply air temperature.

The supply air inlet temperature is cooler than the extract air inlet temperature and the user control is demanding cold supply air temperature.

2.0 Installation

Installation must be carried out by competent personnel in accordance with the appropriate authority and conforming to all statutory and governing regulations.

The unit must be fitted/mounted on roof joists using AV mounts (See figure 2 and 3). Details of this procedure and

Installation of the diffuser can be found in any of the three Installation and Maintenance leaflets listed previously.

Figure 2. Heat exchange unit shown linked to DRIMASTER or DRIMASTER 2000 PIV unit mounted on roof joists using AV mounts.

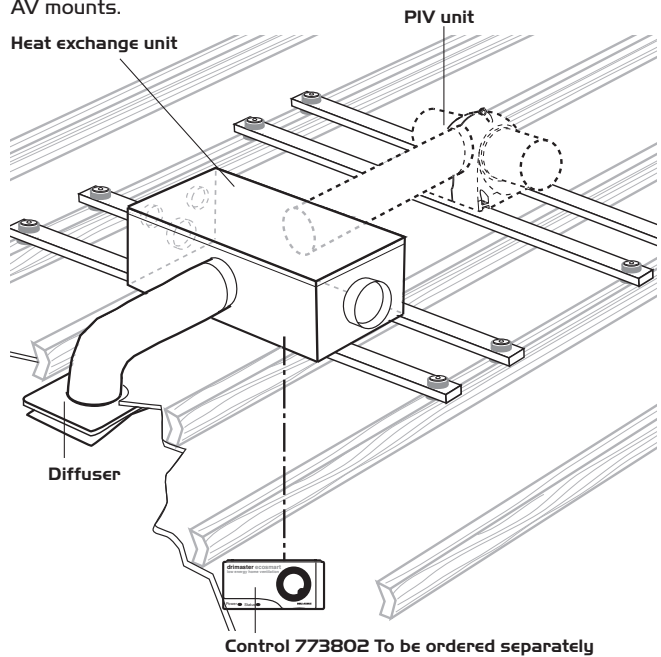
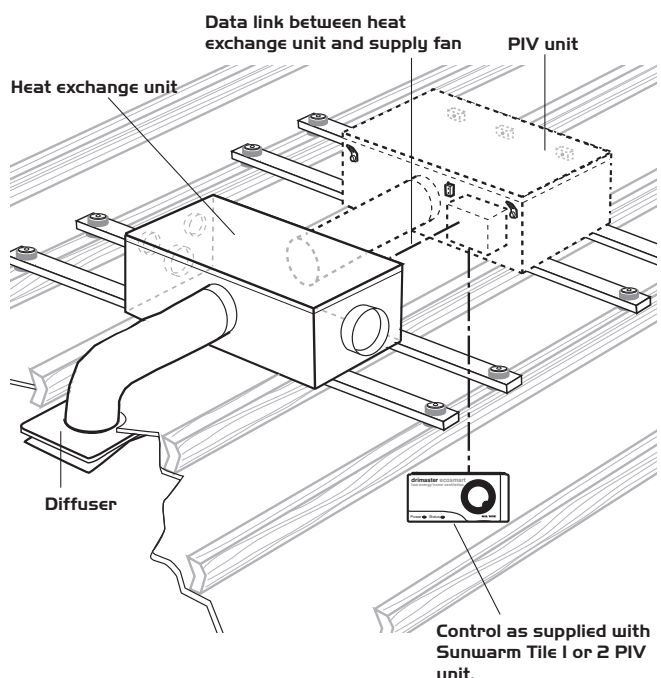

Figure 3. Heat exchange unit shown linked to Sunwarm Tile 1 or 2 PIV unit mounted on roof joists using AV mounts.



2.1 Unit fixing

Various damper/inlet spigot positions can be utilised. All inlet dampers are 'closed' as knockouts when delivered but can be opened using a sharp knife. (See figure 4). After the spigot has been fixed adjust the damper with a screwdriver. (See figure 5).

Figure 4.

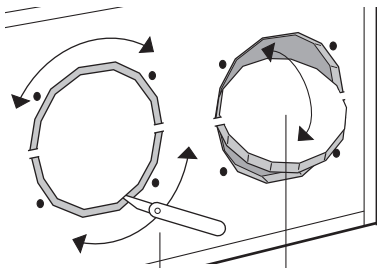

Cut through the acoustic foam round the circumference of the damper. Damper can be swivelled on the 2 body casing hinges.

Figure 5.

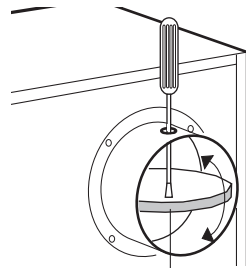

When spigot is in position, damper can be adjusted using a screwdriver.

The spigot locations are as follows:

- Two x 100mm extract air end spigots.
- One x 150mm extract air end spigot.
- One x 200mm discharge spigot for taking air to outside.
- One x 200mm intake spigot for taking air from PIV unit.
- One x 200mm supply spigot for taking air to PIV supply air diffuser.

Any, or all, of the extract spigots can be utilised and connected to ducting as required.

IMPORTANT

Isolation - Before commencing work make sure that the unit is electrically isolated from the mains supply.

4.0 Electrical connection

Connect a 230V 50Hz single-phase power supply to the circuit as shown in figure 7.

To set the extract fan to run at maximum speed, connect a 230V single-phase signal into the terminal SL.

Connect data cable to the user control or the supply fan via the connector labelled 'Net'.

Figure 7.

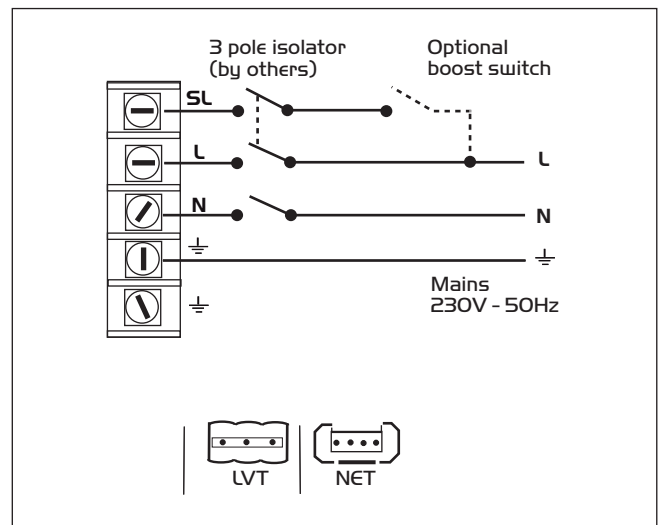

3.0 Dimensions

Figure 6.

END VIEW

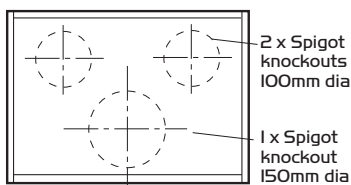

SIDE VIEW

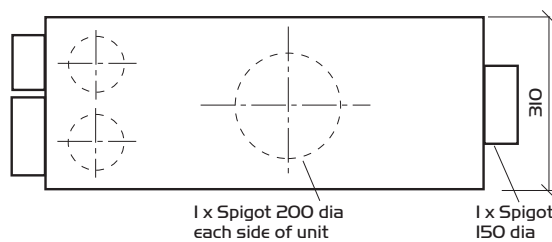

VIEW FROM TOP WITH COVER REMOVED

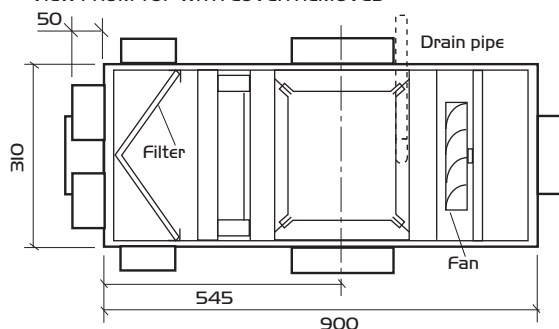

5.0 Fitting a Drainpipe

Figure 8.

PLAN VIEW OF ECOHEATEX

The drain pipe can be fitted on either side of the unit as shown below and should have a slight downward slope to allow the condensate to drain away. The mating surfaces between the elbow, the copper pipe and the drain pipe should be sealed with silicon.

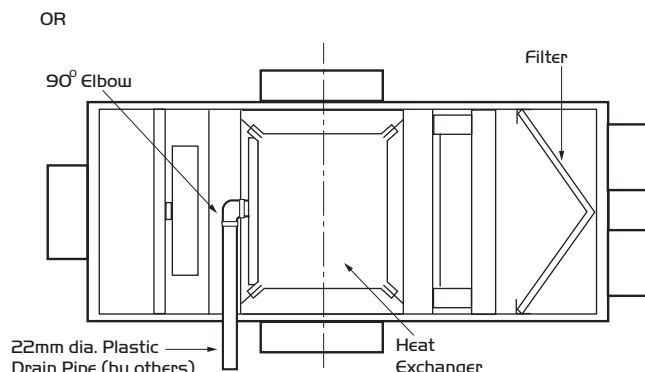
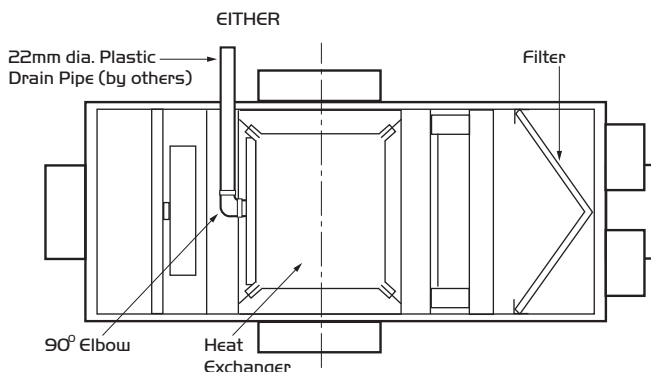

6.0 Commissioning adjustment

The unit is designed to operate continuously at a low trickle speed and boost to a high speed when a switched live signal is present. The fan will continue to run at boost speed for a preset period (1 - 60 minutes) when the signal is removed.

Note: Run on is only available from this switched live (SL) signal.

To adjust the trickle speed, rotate the adjustment pot marked 'Min' until the desired speed is reached.

To adjust the boost speed, rotate the adjustment pot marked 'Max' until the desired speed is reached.

If continuous trickle running is not required, un-plug the link marked 'Trickle' and plug it back in but over one pin only.

To adjust the boost run-on time period, rotate the adjustment pot marked 'Run-on'.

Figure 9.

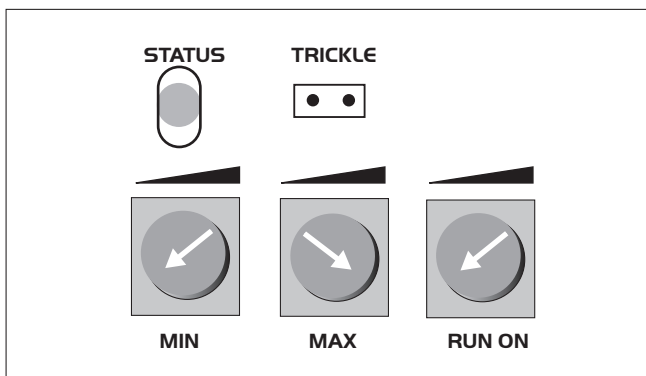

IMPORTANT

Isolation - Before commencing work make sure that the unit is electrically isolated from the mains supply.

IMPORTANT

Unit must not be switched off, product is designed to run continuously.

7.0 Maintenance

Even with filtered extract grilles it is inevitable that some dust, fluff etc. will if allowed, build up internally on motors and impellers, shortening the life of the unit and, in severe cases, leading to overheating of the motors.

Consequently, it is strongly recommended that all units are inspected and cleaned every six months. To clean the heat exchanger remove from the unit and wash in tepid water to which a little mild detergent has been added. Shake out excess water and allow to dry naturally. Replace when dry.

8.0 Cleaning

Remove the cover and carefully clean out interiors. Check for damage and security of components. Refit cover.

9.0 Replacement of Parts

Should any component need replacing Nuaire keep extensive stocks for quick delivery. Ensure that the unit is electrically isolated, before carrying out any work.

When ordering spare parts, please quote the serial number of the unit and the ARC number of the purchase if possible. (This information will be available on the fan label).

10.0 Warranty

5 years warranty from the date of delivery, 1st year for parts and labour, the remaining 4 years parts only. This warranty is conditional on planned maintenance being undertaken.

11.0 Service Enquiries

Nuaire can assist you in all aspects of service. Our Technical Support department will be happy to provide any assistance required.



Telephone 029 2085 8400
Fax 029 2085 8444

DECLARATION OF INCORPORATION AND INFORMATION FOR SAFE INSTALLATION, OPERATION AND MAINTENANCE

We declare that the machinery named below is intended to be assembled with other components to constitute a system of machinery. The machinery shall not be put into service until the system has been declared to be in conformity with the provisions of the EC Machinery Directive.

Designation of machinery: ECOHEATEX-2
 Machinery Types: Heat Exchange Unit
 Relevant EC Council Directives: 2006/42/EC (Machinery Directive)
 Applied Harmonised Standards: BS EN ISO 12100-1, BS EN ISO 12100-2, EN294, EN60204-1, BS EN ISO 9001
 Applied National Standards: BS848 Parts One, Two and Five

Signature of manufacture representatives:

Name:	Position:	Date:
1) C. Biggs 	Technical Director	20. 07. 07
2) A. Jones 	Manufacturing Director	20. 07. 07

INFORMATION FOR SAFE INSTALLATION, OPERATION AND MAINTENANCE OF NUAIRE VENTILATION EQUIPMENT

To comply with EC Council Directives 2006/42/EC Machinery Directive and 2004/108/EC (EMC).

To be read in conjunction with the relevant Product Documentation (see 2.1)

1.0 GENERAL

1.1 The equipment referred to in this Declaration of Incorporation is supplied by Nuairé to be assembled into a ventilation system which may or may not include additional components.

The entire system must be considered for safety purposes and it is the responsibility of the installer to ensure that all of the equipment is installed in compliance with the manufacturers recommendations and with due regard to current legislation and codes of practice.

2.0 INFORMATION SUPPLIED WITH THE EQUIPMENT

2.1 Each item of equipment is supplied with a set of documentation which provides the information required for the safe installation and maintenance of the equipment. This may be in the form of a Data sheet and/or Installation and Maintenance instruction.

2.2 Each unit has a rating plate attached to its outer casing. The rating plate provides essential data relating to the equipment such as serial number, unit code and electrical data. Any further data that may be required will be found in the documentation. If any item is unclear or more information is required, contact Nuairé.

2.3 Where warning labels or notices are attached to the unit the instructions given must be adhered to.

3.0 TRANSPORTATION, HANDLING AND STORAGE

3.1 Care must be taken at all times to prevent damage to the equipment. Note that shock to the unit may result in the balance of the impeller being affected.

3.2 When handling the equipment, care should be taken with corners and edges and that the weight distribution within the unit is considered. Lifting gear such as slings or ropes must be arranged so as not to bear on the casing.

3.3 Equipment stored on site prior to installation should be protected from the weather and steps taken to prevent ingress of contaminants.

4.0 OPERATIONAL LIMITS

4.1 It is important that the specified operational limits for the equipment are adhered to e.g. operational air temperature, air borne contaminants and unit orientation.

4.2 Where installation accessories are supplied with the specified equipment eg. wall mounting brackets. They are to be used to support the equipment only. Other system components must have separate provision for support.

4.3 Flanges and connection spigots are provided for the purpose of joining to duct work systems. They must not be used to support the ductwork.

4.4 In the event of RF interference the fan may increase in speed or make high pitched noises. This is normal and will have no adverse effect on the fan. The speed and noise will return to normal once the interference has subsided.

5.0 INSTALLATION REQUIREMENTS

In addition to the particular requirements given for the individual product, the following general requirements should be noted.

- 5.1 Where access to any part of equipment which moves, or can become electrically live are not prevented by the equipment panels or by fixed installation detail (eg ducting), then guarding to the appropriate standard must be fitted.
- 5.2 The electrical installation of the equipment must comply with the requirements of the relevant local electrical safety regulations.
- 5.3 For EMC all control and sensor cables should not be placed within 50mm or on the same metal cable tray as 230V switched live, lighting or power cables and any cables not intended for use with this product.

6.0 COMMISSIONING REQUIREMENTS

- 6.1 General pre-commissioning checks relevant to safe operation consist of the following:
 Ensure that no foreign bodies are present within the fan or casing.
 Check electrical safety. e.g. Insulation and earthing.
 Check guarding of system.
 Check operation of Isolators/Controls.
 Check fastenings for security.
- 6.2 Other commissioning requirements are given in the relevant product documentation.

7.0 OPERATIONAL REQUIREMENTS

- 7.1 Equipment access panels must be in place at all times during operation of the unit, and must be secured with the original fastenings.
- 7.2 If failure of the equipment occurs or is suspected then it should be taken out of service until a competent person can effect repair or examination. (Note that certain ranges of equipment are designed to detect and compensate for fan failure).

8.0 MAINTENANCE REQUIREMENTS

- 8.1 Specific maintenance requirements are given in the relevant product documentation.
- 8.2 It is important that the correct tools are used for the various tasks required.
- 8.3 If the access panels are to be removed for any reason the electrical supply to the unit must be isolated.
- 8.4 A minimum period of two minutes should be allowed after electrical disconnection before access panels are removed. This will allow the impeller to come to rest.
NB: Care should still be taken however since airflow generated at some other point in the system can cause the impeller to "windmill" even when power is not present.
- 8.5 Care should be taken when removing and storing access panels in windy conditions.

Technical or commercial considerations may, from time to time, make it necessary to alter the design, performance and dimensions of equipment and the right is reserved to make such changes without prior notice.