

Axis AXB

Circular Bifurcated Axial Flow Fans Installation and Maintenance

CE The EMC Directive
2014/30/EU
The Low Voltage
directive
2014/35/EU

Introduction

The AXUS Bifurcated range of axial flow fans are designed for 'in duct' applications. Manufactured from galvanised steel they are suitable for in, or out door installation and at any installed angle.

Available for single and three phase supplies.

Case diameters of 315mm to 1250mm.

Unit codes AXB31 to AXB125.

Impellers have been selected at blade angle settings matched to various motor speeds to perform against the design criteria laid down in our selection catalogue.

Any attempt to adjust or reset impeller blade angles will invalidate warranty.

For full unit description, dimensional, weight and performance details refer to our catalogue, pages 25 to 30.

Our comprehensive range of ancillaries and silencers are on pages 51 to 58.

Handling

The fan impeller is carefully balanced and centralised in the fan case, it is therefore essential that great care is exercised when handling the unit. Never pass lifting slings through the impeller (figure 2), check the weight on the rating plate details before attempting to lift and always use a spreader as shown in figure 1.

Figure 1. Correct method of lifting using a spreader.

Figure 2. The wrong method of lifting with sling through impeller can cause case distortion.

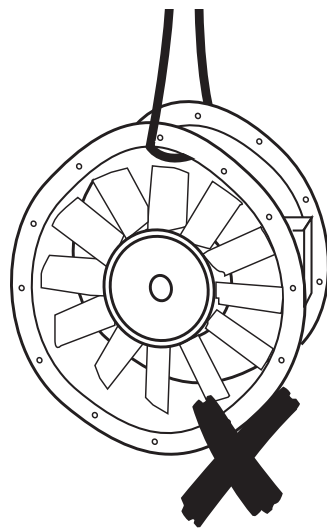
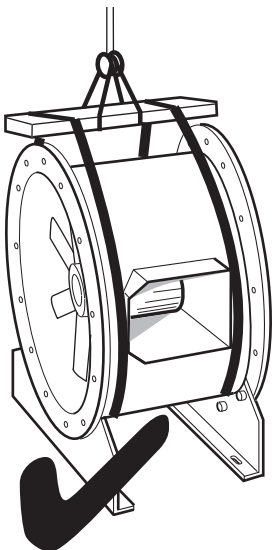

Installation and General Advice

Installation must be carried out by competent personnel, in accordance with good industry practice, the appropriate authority and in conformance with all statutory and governing

regulations e.g. IEE, CIBSE, HVCA, ATEX, BSI & EN standards etc.

If the fan is to be installed in a potentially explosive atmosphere it will have been designed to ATEX-100 directive 94/9/EC and will incorporate motors requiring compatible installation wiring direct to the motor termination box, to complete this installation also follow the guidance advice of data sheet 671216.

Before commencing installation check that all material, including optional ancillaries are available to complete the installation. Every unit is tested and serialised at works and a test certificate produced, the details recorded on the fan side rating plate should also be referred to before handling and installation.

Any damages or deviations should be immediately reported to the seller/supplier/agent quoting the order and product details from the product rating plate.

Mechanical Installation

Rotate the fan impeller by hand to ensure free and smooth rotation and that no transit or handling damage has occurred, observe the direction of flow/direction of rotation arrow and ensure that :

- All optional accessories such as support brackets, attenuators, inlet cones, guards, flexible connectors etc. are assembled to the fan.
- The optional support brackets are correctly fitted, at any position around the circumference, but suit the installation plane.
- External termination box is accessible to the electrician.
- When offering the fan to the ducted system that both inlet and outlet connections are perfectly aligned.
- In order to ensure performance is as stated, a minimum distance of twice the fan diameter is required between the appliance and any bends in the ductwork.

Horizontal on Floor or Supported from Wall etc

Optional resilient mountings should be attached to the unit mounting brackets at this stage. (See figure 3).

If the unit is supported from a wall, supporting brackets should be used. Position and align the unit with the ductwork in both horizontal and vertical planes and pack height under mounting feet if necessary.

Matching attenuators if required, should be fitted to the fan with any other accessories before installation.

Matching flanges are fixed to the ductwork ends with rivets.

cont. on page 2.

Suspended Horizontally or Vertically

A.V. mountings must be arranged so that they are used in compression only. If Resilient Mountings NAV1 to NAV5 are specified the rubber mountings must also remain in compression. The large metal washers must be fitted under the studding nuts on each mounting. (See figure 4).

Other types of A.V. mounts - spring etc are also designed to be used in compression only. A suspended steel under frame would be necessary to support the unit, (by others) standing on A.V. mountings.

AV Mounts isolate the fan only. Silencers/backdraught dampers and other "significant mass" accessories should form part of the fixed ductwork after the flexible connection.

Figure 3. Resilient Mounting 'Floor' fixing.

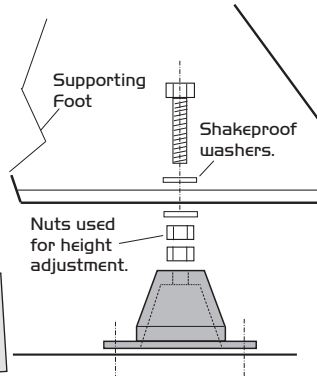
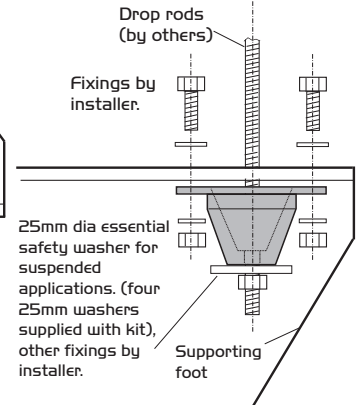

Figure 4. Resilient Mounting 'Suspended' fixing.



Electrical Installation

Units are not supplied with electrical isolators, their selection and provision is the responsibility of the installer.

Ensure the electrical supply is suitable for the fan and that all wiring, fuse and overload protection etc is appropriately sized by comparing with the rating plate.

Electrical connection is made direct to the motor termination box on all fans, if explosion proof motors are fitted they will require matched spec' wiring, refer to data sheet 671216 for additional advice.

Wiring connection diagrams; where a starter, frequency inverter or Ecosmart control is used also refer to the relevant control I&M instructions. Bifurcated fans should only be speed controlled by a frequency inverter.

It is essential to note that for all three phase fans of 4KW and above the final connection must be in DELTA.

If a Star/Delta starter is to be used connect all six motor terminals to the appropriate terminals of the starter, if the fan is to be started direct on line (DOL), to a frequency inverter or Nuair's Ecosmart speed control the motor must be connected in Delta.

Wiring Diagrams

Single Speed 1 phase

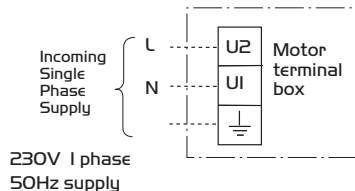

230V 1 phase 50Hz supply

(Not speed controllable)

Single Speed 3 phase (below 4kW)

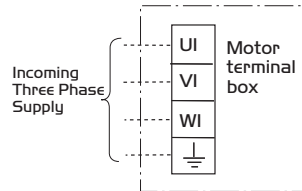

400V 3 phase 50HZ supply

3 phase for STAR /DELTA STARTING (4kW and above)

400V 3 phase 50Hz supply

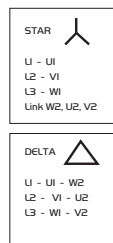

Note: For D.O.L (Direct On Line Starting) operation or Inverter type Speed Control, wire in DELTA Δ

3 phase for DOL STARTING (4kW and above) 400V 3 phase 50Hz supply

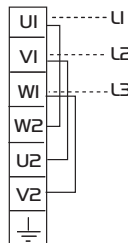

2 SPEED TAP/ PAM WOUND MOTOR (D.O.L. starting both speeds) Note: individual wiring instructions are included with each unit

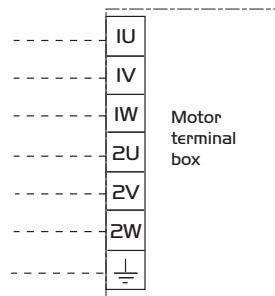

400V 3 phase 50HZ supply

NOTE:
LOW SPEED - Supply: IU IV IW
HIGH SPEED - Supply: 2U 2V 2W & link IU IV IW

Wiring diagrams continued on page 3.

Wiring Diagrams cont.

Matched Inverter Speed Control

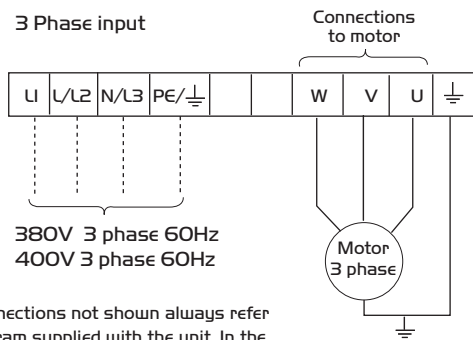

For specialist connections not shown always refer to the wiring diagram supplied with the unit. In the event of query or uncertainty contact NUAIRE directly before any connection is made.

AXB units are suitable for INVERTER SPEED CONTROL only

Notes:
Total length of motor leads should not exceed 50 metres.

If a screened motor cable is used, maximum length should be 25 metres. Consult our Technical Department if you wish to use longer leads.

Inverters are configured to suit specific fans and control applications as described on the Customer Order free of charge.

Isolation - Before removing panels make sure that the unit is electrically isolated from the mains supply.

Setting to Work

Ensure all mechanical and electrical connections and fixings are secure and that inlet and outlet duct work is free of any obstruction or debris. Briefly switch the fan on/off to ascertain correct direction of rotation, compare the rotational label applied to the fan case and correct if necessary.

Maintenance

Only appropriately qualified personnel, familiar not only with the electrical aspect of the work but with the plant, area or application served by the unit, should carry out routine and preventative maintenance on this product.

Maintenance Intervals

Maintenance should be carried out on a regular basis, we recommend three months from commissioning and at least annually thereafter as determined by the operating conditions and levels of airborne contamination to which the unit is exposed.

Maintenance Checklist ✓

Item	Tick
Check that bird guards/safety grilles are secure and free of obstruction.	
Inspect all bolts, fixings and electrical terminals for security.	
Check motor for undue wear, signs of over heating and apply winding insulation and continuity tests.	
Remove all dust and dirt from impellers, be especially careful not to disturb balance weights.	
Generally clean.	
Check resilient mounts and replace any that show signs of wear or deterioration.	

Lubrication

Motors are fitted with sealed for life bearings and do not require any lubrication.

Impellers

Impellers are dynamically balanced during manufacture, no special treatment is required during maintenance, other to clean and remove all dust and dirt residue taking care not to disturb the balance weights. Remove stubborn dirt with warm soapy water – do not use caustic fluids.

If ATEX compliant, observe the advice of guidance note document 671216.

The maintenance programme must conform to 'good custom and practice' and to the published recommendations of associations such as the HVCA, CIBSE etc. The HVCA's publication 'Standard Maintenance Specification for Mechanical Services in Buildings' Vol 2 Ventilating and Air Conditionings a recommended reference.

Replacement of Parts

Should any component need replacing Nuair keep extensive stocks for quick delivery. Ensure that the unit is electrically isolated, before carrying out any work.

When ordering spare parts, please quote the serial number of the unit and the ARC number of the purchase if possible (this information will be available on the fan label).

Warranty

The 3 year warranty starts from the day of delivery and includes parts and labour for the first year. The remaining period covers replacement parts only.

This warranty is void if the equipment is modified without authorisation, is incorrectly applied, misused, disassembled, or not installed, commissioned and maintained in accordance with the details contained in this manual and general good practice.

The product warranty applies to the UK mainland and in accordance with Clause 14 of our Conditions of Sale. Customers purchasing from outside of the UK should contact Nuair International Sales office for further details.

After Sales

For technical assistance or further product information, including spare parts and replacement components, please contact the After Sales Department.

Telephone 02920 858 400

DECLARATION OF INCORPORATION AND INFORMATION FOR SAFE INSTALLATION, OPERATION AND MAINTENANCE



We declare that the machinery named below is intended to be assembled with other components to constitute a system of machinery. The machinery shall not be put into service until the system has been declared to be in conformity with the provisions of the EC Machinery Directive.

Designation of machinery: AXUS BIFURCATED FAN
 Machinery Types: AXB
 Relevant EC Council Directives: 2006/42/EC (Machinery Directive)

Applied Harmonised Standards: BS EN ISO 12100-1, BS EN ISO 12100-2, EN294, EN60204-1, BS EN ISO 9001

Applied National Standards: BS848 Parts One, Two and Five

Signature of manufacture representatives:

Name:	Position:	Date:
1) C. Biggs 	Technical Director	20. 07. 07
2) A. Jones 	Manufacturing Director	20. 07. 07

INFORMATION FOR SAFE INSTALLATION, OPERATION AND MAINTENANCE OF NUAIRE VENTILATION EQUIPMENT

To comply with EC Council Directives 2006/42/EC Machinery Directive and 2014/30/EC (EMC).

To be read in conjunction with the relevant Product Documentation (see 2).

1.0 GENERAL

1.1 The equipment referred to in this Declaration of Incorporation is supplied by Nuaire to be assembled into a ventilation system which may or may not include additional components.

The entire system must be considered for safety purposes and it is the responsibility of the installer to ensure that all of the equipment is installed in compliance with the manufacturers recommendations and with due regard to current legislation and codes of practice.

2.0 INFORMATION SUPPLIED WITH THE EQUIPMENT

2.1 Each item of equipment is supplied with a set of documentation which provides the information required for the safe installation and maintenance of the equipment. This may be in the form of a Data sheet and/or Installation and Maintenance instruction.

2.2 Each unit has a rating plate attached to its outer casing. The rating plate provides essential data relating to the equipment such as serial number, unit code and electrical data. Any further data that may be required will be found in the documentation. If any item is unclear or more information is required, contact Nuaire.

2.3 Where warning labels or notices are attached to the unit the instructions given must be adhered to.

3.0 TRANSPORTATION HANDLING AND STORAGE

3.1 Care must be taken at all times to prevent damage to the equipment. Note that shock to the unit may result in the balance of the impeller being affected.

3.2 When handling the equipment, care should be taken with corners and edges and that the weight distribution within the unit is considered. Lifting gear such as slings or ropes must be arranged so as not to bear on the casing.

3.3 Equipment stored on site prior to installation should be protected from the weather and steps taken to prevent ingress of contaminants.

4.0 OPERATIONAL LIMITS

4.1 It is important that the specified operational limits for the equipment are adhered to e.g. operational air temperature, air borne contaminants and unit orientation.

4.2 Where installation accessories are supplied with the specified equipment e.g. wall mounting brackets. They are to be used to support the equipment only. Other system components must have separate provision for support.

4.3 Flanges and connection spigots are provided for the purpose of joining to duct work systems. They must not be used to support the ductwork.

5.0 INSTALLATION REQUIREMENTS

In addition to the particular requirements given for the individual product, the following general requirements should be noted.

5.1 Where access to any part of equipment which moves, or can become electrically live are not prevented by the equipment panels or by fixed installation detail (eg ducting), then guarding to the appropriate standard must be fitted.

5.2 The electrical installation of the equipment must comply with the requirements of the relevant local electrical safety regulations.

5.3 For EMC all control and sensor cables should not be placed within 50mm or on the same metal cable tray as 230V switched live, lighting or power cables and any cables not intended for use with this product.

6.0 COMMISSIONING REQUIREMENTS

6.1 General pre-commissioning checks relevant to safe operation consist of the following:

Ensure that no foreign bodies are present within the fan or casing. Check electrical safety. e.g. Insulation and earthing.
 Check guarding of system.
 Check operation of Isolators/Controls.
 Check fastenings for security.

6.2 Other commissioning requirements are given in the relevant product documentation.

7.0 OPERATIONAL REQUIREMENTS

7.1 Equipment access panels must be in place at all times during operation of the unit, and must be secured with the original fastenings.

7.2 If failure of the equipment occurs or is suspected then it should be taken out of service until a competent person can effect repair or examination. (Note that certain ranges of equipment are designed to detect and compensate for fan failure).

8.0 MAINTENANCE REQUIREMENTS

8.1 Specific maintenance requirements are given in the relevant product documentation.

8.2 It is important that the correct tools are used for the various tasks required.

8.3 If the access panels are to be removed for any reason the electrical supply to the unit must be isolated.

8.4 A minimum period of two minutes should be allowed after electrical disconnection before access panels are removed. This will allow the impeller to come to rest.

NB: Care should still be taken however since air flow generated at some other point in the system can cause the impeller to "windmill" even when power is not present.

8.5 Care should be taken when removing and storing access panels in windy conditions.

Technical or commercial considerations may, from time to time, make it necessary to alter the design, performance and dimensions of equipment and the right is reserved to make such changes without prior notice.