

# Squif - SQFA

## Single In-line Fans 50/60Hz

### Installation and Maintenance

**nuaire**

**CE** The EMC Directive  
2014/30/EU  
The Low Voltage  
Directive  
2014/35/EU

## 1.0 INTRODUCTION

The Squif range of fans are designed for in-duct applications. Manufactured from galvanised steel, they are suitable for in or outdoor installation and can be installed in a horizontal or vertical attitude.

For full unit description, dimensional, weight and performance details refer to Nuaire catalogue.

## 2.0 HANDLING

Handle the unit with care. Note the weight from the rating plate, lift using slings attached to the four lifting eyes as (see fig. 1).

Figure 1.

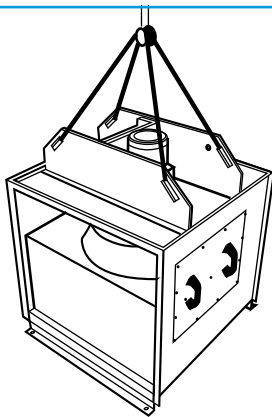

## 3.0 INSTALLATION AND GENERAL ADVICE

Installation must be carried out by competent personnel, in accordance with good industry practice, the appropriate authority and in conformance with all statutory and governing regulations e.g. IEE, CIBSE, COHSE, HVCA, BSI and EN standards etc.

Before commencing installation check that all material, including mounting feet and optional ancillaries are available to complete the work. Every unit is tested and serialised at works and a test certificate produced, the details are also recorded on the fan side rating plate which should also be referred to before handling and installation. Any damage or deviations should be immediately reported to the seller/supplier/agent quoting the order and rating plate details.

### IMPORTANT

Please ensure that there is adequate clearance for the removal of the motor/fan assembly for maintenance purposes.

### 3.1 Mechanical Installation

Fans are suitable for both internal and external installation and whilst they can be installed in either a vertical or horizontal attitude, the standard bracketry provided is suitable only for the more conventional vertical mounting position.

For horizontal mounting (fig. 3), observe the centre of gravity (approximately 100 - 150mm left of flange) and fit an angle bracket or unistrut steel bar (not supplied) to brace the unit. Fit AV mounts equidistant of CG line and at a safe distance so as to level unit.

Figure 2.  
Preferred vertical  
mounting  
(bracket supplied).

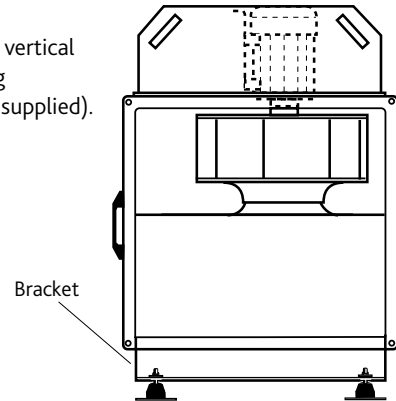
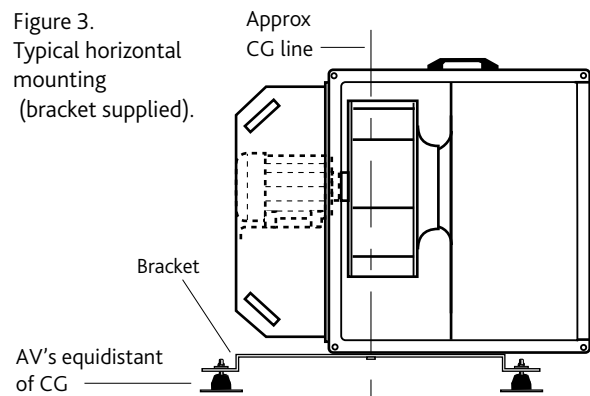

Figure 3.  
Typical horizontal  
mounting  
(bracket supplied).



Rotate the fan impeller by hand to ensure free and smooth rotation and that no handling or transit damage has occurred, observe the direction of flow/direction of rotation arrow and ensure that:

- All optional accessories such as support brackets, attenuators, guards, flexible connectors etc. are assembled to the fan.
- Support brackets are fitted appropriate for the installed attitude - vertical or horizontal.
- When offering the fan to the ducted system that both inlet and outlet connections are perfectly aligned.

It is advisable to fit flexible connectors on either side of the fan unless there is an open-ended inlet or discharge and the fan should be supported on AV mounts. The AVs should be levelled off to maximise isolation and the flexible connectors correctly aligned with the fan at the correct tension.

### IMPORTANT

AV mounts isolate the fan only. Silencers/backdraught dampers and other "significant mass" accessories should form part of the fixed ductwork after the flexible connection.

# Installation and Maintenance

## Squif Single In-line Fans

### 3.2 Electrical installation

Units are not supplied with electrical isolators, their selection and provision is the responsibility of the installer.

Ensure the electrical supply is suitable for the fan and that all the wiring, fuses and overload protection etc. is appropriately sized by comparing with the rating plate.

Electrical connection is made direct to the motor on all three phase fans and to a termination box on single phase fans. Where a starter, speed control, frequency inverter or Ecosmart control is used also refer to the control I&M instructions.

It is essential to note that for all three phase motors of 4kW and above the final connection must be DELTA and:

- If a star/delta starter is to be used connect the six motor terminals directly to the starter.
- If a frequency inverter or Ecosmart speed control is to be used connect in DELTA.
- If the fan is to be started direct on line (DOL) connect the motor in DELTA.

### IMPORTANT

When the unit is operated in emergency mode smoke extract operation - all controls must be bypassed.

### 4.0 WIRING DIAGRAMS

Single Phase units with 0.37KW, 0.75KW and 1.1KW motors, connections are made to the fan side termination box.

Figure 4. Single phase, single speed.

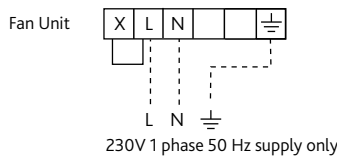

3 phase motors are connected directly to the motor terminal box.

Figure 5. 3 phase units up to 3 kW.

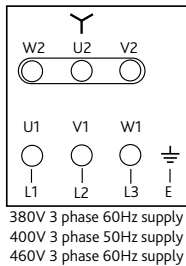

Figure 6. 3 phase units 4kW and above.

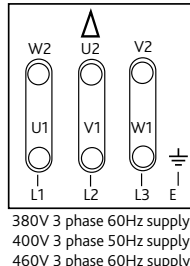

Figure 7. Two speed motors DOL starting on both speeds - observe the motor plate and connection details.

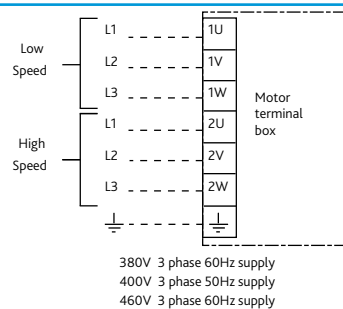
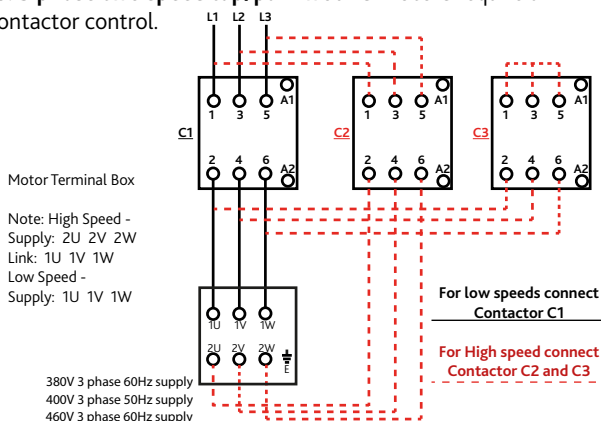
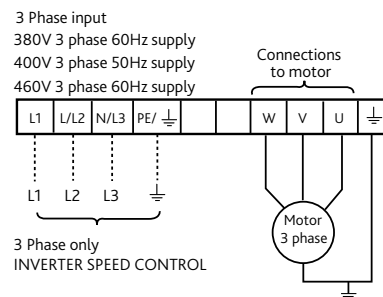

Figure 8. 3 phase two speed tap/pam wound motors require a three contactor control.



3 phase Dual wound motors require a two contactor control.

Figure 9. 3 phase units with matched frequency inverter single speed.



Note: Screened cable must be used. Maximum length should be 30m and must be earthed at both ends and continually earthed through any insulators.

Figure 10. 3 phase (Ecosmart Control)

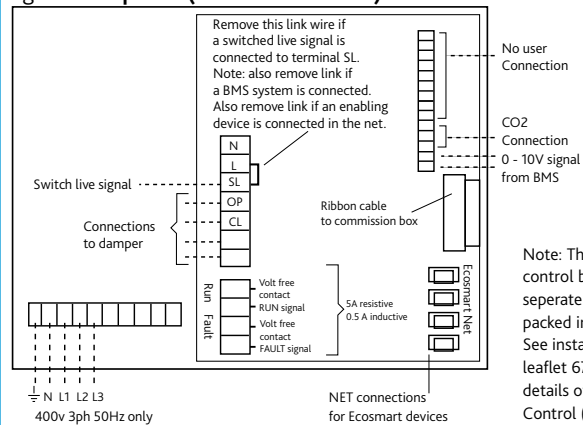

Note: The Ecosmart control box is a separate item packed individually. See installation leaflet 671432 for details of Ecosmart Control (ES-ISC).

Figure 11. Set up/Commissioning Box

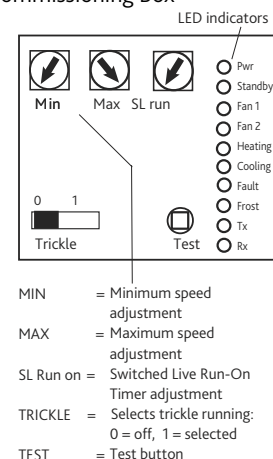

- MIN = Minimum speed adjustment
- MAX = Maximum speed adjustment
- SL Run on = Switched Live Run-On Timer adjustment
- TRICKLE = Selects trickle running: 0 = off, 1 = selected
- TEST = Test button

# Installation and Maintenance

## Squif Single In-line Fans

### 5.0 SETTING TO WORK

#### IMPORTANT

Isolation - Before commencing work make sure that the unit and Nuaire control are electrically isolated from the mains supply.

Ensure that all mechanical and electrical connections and fixings are secure and that inlet and outlet ductwork is free of any obstruction or debris.

Briefly switch the fan on/off to ascertain correct direction of impeller rotation, compare with the rotational label fitted and correct if necessary.

Complete the test by running the fan for approximately 15 minutes, taking and comparing voltage, full load and starting currents with the fan rating label. Monitor flexible connections to ensure no leakage and AV mounts for correct alignment.

### 6.0 MAINTENANCE INTERVALS

The first maintenance should be carried out three months after commissioning and thereafter at twelve monthly intervals.

These intervals may need to be shortened if the unit is operating in adverse environmental conditions, or in heavily polluted air.

#### 6.1 Maintenance Check List

ITEM	TICK
Check that safety grilles are secure and free of obstruction.	
Inspect all bolts, fixings and electrical terminals for security.	
Check motor for undue wear, signs of overheating and apply winding insulation and continuity tests.	
Remove all dust and dirt from impellers; be especially careful not to disturb balance weights.	
Generally clean.	
Check resilient mounts (where applicable) and replace any that have any wear or deterioration.	

#### 6.2 Lubrication

Motors are fitted with sealed for life bearings and do not require any lubrication.

#### 6.3 General Cleaning and Inspection

Clean and inspect the exterior of the fan unit and associated controls etc. Remove the access panel from the fan unit. Inspect and, if necessary, clean the fan impeller and motor assemblies and the interior of the case.

Check all parts for security and condition. Check that the impeller rotates freely and the inlet cone and impeller are concentric with a running clearance.

### 7.0 REPLACEMENT OF PARTS

Should any component need replacing, Nuaire keep extensive stocks for quick delivery. Ensure that the unit is electrically isolated, before carrying out any work.

When ordering spare parts, please quote the serial number of the unit and the ARC number of the purchase if possible (**This information will be available on the fan label**).

### 8.0 WARRANTY

A Squif unit has a 3 year warranty and an Ecosmart Squif unit has a 5 year warranty. The warranty starts from the day of delivery and includes parts and labour for the first year, the remaining years covers replacement parts only.

This warranty is void if the equipment is modified without authorisation, is incorrectly applied, misused, disassembled, or not installed, commissioned and maintained in accordance with the details contained in this manual and general good practice.

The product warranty applies to the UK mainland and in accordance with Clause 14 of our Conditions of Sale.

Customers purchasing from outside of the UK should contact Nuaire International Sales office for further details.

### 9.0 AFTER SALES ENQUIRIES

For technical assistance or further product information, please contact the After Sales department.

Telephone 02920 858 400  
[aftersales@nuaire.co.uk](mailto:aftersales@nuaire.co.uk)

Technical or commercial considerations may, from time to time, make it necessary to alter the design, performance and dimensions of equipment and the right is reserved to make such changes without prior notice.

## DECLARATION OF INCORPORATION AND INFORMATION FOR SAFE INSTALLATION, OPERATION AND MAINTENANCE

We declare that the machinery named below is intended to be assembled with other components to constitute a system of machinery. All parts except for moving parts requiring the correct installation of safety guards comply with the essential requirements of the Machinery Directive. The machinery shall not be put into service until the system has been declared to be in conformity with the provisions of the EC Machinery Directive.

Designation of machinery: SQUIF SINGLE IN-LINE FAN

Machinery Types: SQFA

Relevant EC Council Directives: 2006/42/EC (Machinery Directive)

Applied Harmonised Standards: BS EN ISO 12100-1, BS EN ISO 12100-2, EN60204-1, BS EN ISO 9001, BS EN ISO 13857

Applied National Standards: BS848 Parts 1, 2.2 and 5

### Signature of manufacture representatives:

Name:	Position:	Date:
1) C. Biggs 	Technical Director	11. 05. 11
2) A. Jones 	Manufacturing Director	11. 05. 11

Note: All standards used were current and valid at the date of signature.

## CE DECLARATION OF CONFORMITY

We declare that the machine named below conforms to the requirements of EC Council Directives relating to Electromagnetic Compatibility and Safety of Electrical Equipment.

Designation of machinery: SQUIF SINGLE IN-LINE FAN

I & M Serial No.: 671175

Machinery Types: SQFA

Relevant EC Council Directives: 2014/30/EU (EMC), 2014/35/EU (Low Voltage Directive)

Applied Harmonised Standards: EN55014-1, EN55014-2, EN61000-3-2, EN61000-3-3, EN60335-2-80

Basis of Self Attestation: Quality Assurance to BS EN ISO 9001  
BSI Registered Firm Certificate No. FM 149

### Signature of manufacture representatives:

Name:	Position:	Date:
1) C. Biggs 	Technical Director	11. 05. 11
2) A. Jones 	Manufacturing Director	11. 05. 11

Nuaire: A Trading Division of Polypipe,  
Western Industrial Estate,  
Caerphilly,  
CF83 1NA.

Note: All standards used were current and valid at the date of signature.

## INFORMATION FOR SAFE INSTALLATION, OPERATION AND MAINTENANCE OF NUAIRE VENTILATION EQUIPMENT

To comply with EC Council Directives 2006/42/EC Machinery Directive and 2014/30/EU (EMC).  
To be read in conjunction with the relevant product documentation (see 2.1)

### 1.0 GENERAL

1.1 The equipment referred to in this Declaration of Incorporation is supplied by Nuaire to be assembled into a ventilation system which may or may not include additional components.  
The entire system must be considered for safety purposes and it is the responsibility of the installer to ensure that all of the equipment is installed in compliance with the manufacturers recommendations and with due regard to current legislation and codes of practice.

### 2.0 INFORMATION SUPPLIED WITH THE EQUIPMENT

2.1 Each item of equipment is supplied with a set of documentation which provides the information required for the safe installation and maintenance of the equipment.  
This may be in the form of a Data sheet and/or Installation and Maintenance instruction.  
Each unit has a rating plate attached to its outer casing. The rating plate provides essential data relating to the equipment such as serial number, unit code and electrical data. Any further data that may be required will be found in the documentation.  
If any item is unclear or more information is required, contact Nuaire.

2.2 Where warning labels or notices are attached to the unit the instructions given must be adhered to.

### 3.0 TRANSPORTATION, HANDLING AND STORAGE

3.1 Care must be taken at all times to prevent damage to the equipment. Note that shock to the unit may result in the balance of the impeller being affected.

3.2 When handling the equipment, care should be taken with corners and edges and that the weight distribution within the unit is considered. Lifting gear such as slings or ropes must be arranged so as not to bear on the casing.

3.3 Equipment stored on site prior to installation should be protected from the weather and steps taken to prevent ingress of contaminants.

### 4.0 OPERATIONAL LIMITS

4.1 It is important that the specified operational limits for the equipment are adhered to e.g. operational air temperature, air borne contaminants and unit orientation.

4.2 Where installation accessories are supplied with the specified equipment eg. wall mounting brackets. They are to be used to support the equipment only.  
Other system components must have separate provision for support.

4.3 Flanges and connection spigots are provided for the purpose of joining to duct work systems. They must not be used to support the ductwork.

4.4 **Local Environment - Humidity.** Ambient humidity (the humidity at the unit's installed location) shall be within the range: 10 to 95% (for controls, non-condensing).  
Air humidity (the humidity of the air passing through the unit) shall be within the range: 10 to 95% (for controls, non-condensing).

### 5.0 INSTALLATION REQUIREMENTS

In addition to the particular requirements given for the individual product, the following general requirements should be noted.

5.1 Where access to any part of equipment which moves, or can become **electrically live** are not prevented by the equipment panels or by fixed installation detail (e.g. ducting), then guarding to the appropriate standard must be fitted.

5.2 The electrical installation of the equipment must comply with the requirements of the relevant local electrical safety regulations.

5.3 For EMC all control and sensor cables should not be placed within 50mm or on the same metal cable tray as 230V switched live, lighting or power cables and any cables not intended for use with this product.

### 6.0 COMMISSIONING REQUIREMENTS

6.1 General pre-commissioning checks relevant to safe operation consist of the following:  
Ensure that no foreign bodies are present within the fan or casing.  
Check electrical safety. e.g. Insulation and earthing.  
Check guarding of system.  
Check operation of Isolators/Controls.  
Check fastenings for security.

6.2 Other commissioning requirements are given in the relevant product documentation.

### 7.0 OPERATIONAL REQUIREMENTS

7.1 Equipment access panels must be in place at all times during operation of the unit, and must be secured with the original fastenings.

7.2 If failure of the equipment occurs or is suspected then it should be taken out of service until a competent person can effect repair or examination. (Note that certain ranges of equipment are designed to detect and compensate for fan failure).

### 8.0 MAINTENANCE REQUIREMENTS

8.1 Specific maintenance requirements are given in the relevant product documentation.

8.2 It is important that the correct tools are used for the various tasks required.

8.3 If the access panels are to be removed for any reason the electrical supply to the unit must be isolated.

8.4 A minimum period of two minutes should be allowed after electrical disconnection before access panels are removed. This will allow the impeller to come to rest.  
**NB: Care should still be taken however since airflow generated at some other point in the system can cause the impeller to "windmill" even when power is not present.**

8.5 Care should be taken when removing and storing access panels in windy conditions.