



# AXUS AX

High Temperature 300°C for 2hr, 400°C for 2 hour

## Circular Long Cased Axial Flow Fans Installation and Maintenance



### 1.0 Introduction

The Nuaire Axus range of Long Cased Axial Flow Fans are produced in sixteen case sizes from 315mm dia. to 1600mm dia. with duties up to 65m<sup>3</sup>/s.

Impellers are manufactured in aluminium alloy or steel. These high performance impellers have been selected to provide a range of units that will suit your specific requirements. Note: Nuaire will not accept responsibility for damaged units when unauthorised personnel have altered blade angles.

The fans are available for three phase operation only.

The units are designed for:

**S1 DUTY** Day to day operation and in the event of fire a one off emergency use.

The range has been designed for ease of installation into new or existing ductwork systems. The optional supporting brackets can be located any where around the circumference of the flange allowing the fan to be installed in any mounting plane. Fan units are suitable for internal and external use.

Anti-vibration Mounting kits are available as an ancillary. A full range of additional ancillaries is available including:

Matching flanges, matching attenuators, mounting brackets, flexible connectors, inlet cones and backdraught dampers.

EN12101-3 compliant, refer to EC certificate of conformity, 0086-CPR-672476.

### 2.0 Handling

The fan impeller is carefully balanced and centralised in the fan case, it is therefore essential that great care is exercised when handling the unit. Check the weight on the rating plate details before attempting to lift and always use a spreader as shown (fig. 1), never pass lifting slings through the impeller (fig. 2).

Note care must be taken when handling a unit / attenuator assembly fitted with flexible connectors as the flexibles can be distorted or damaged.

Figure 1. Correct method of lifting using a spreader.

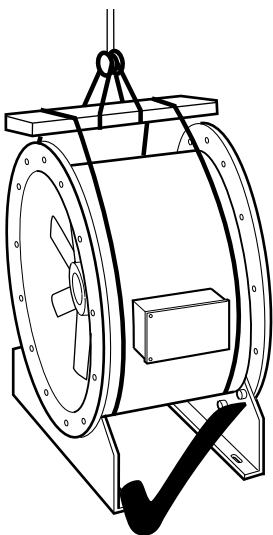
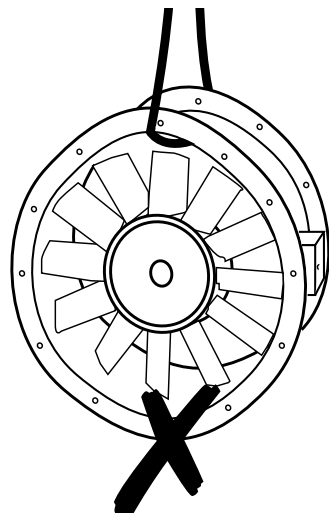

Figure 2. The wrong method of lifting with sling through impeller can cause case distortion.



### 3.0 Installation And General Advice

Installation must be carried out by competent personnel, in accordance with good industry practice, the appropriate authority and in conformance with all statutory and governing regulations e.g. IEE, CIBSE, COSHH, HVCA, ATEX, BSI & EN standards etc.

**Before commencing installation** check that all material, including optional ancillaries are available to complete the installation. Every unit is tested and serialised at works and a test certificate produced, the details recorded on the fan side rating plate should also be referred to before handling and installation.

**Any damages or deviations should be immediately reported to the seller/supplier/agent quoting the order and product details from the product rating plate.**

#### IMPORTANT

**Warning! Do not reverse impeller direction for operation as the performance of the unit is drastically reduced. Do not alter the blade angle of the impeller without the permission of Nuaire, doing so may invalidate your warranty.**

#### 3.1 Mechanical Installation

Rotate the fan impeller by hand to ensure free and smooth rotation and that no transit or handling damage has occurred, observe the direction of flow/direction of rotation arrow and ensure that:

- All optional accessories such as support brackets, attenuators, inlet cones, guards, flexible connectors etc. are assembled to the fan.
- AV mounts isolate the fan only. Attenuators, backdraught dampers and other 'significant mass' accessories should form part of the fixed ductwork after the flexible connection.
- The optional support brackets are correctly fitted, at any position around the circumference, but suit the installation plane.
- External termination box is accessible to the electrician.
- When offering the fan to the ducted system that both inlet and outlet connections are perfectly aligned.
- In order to ensure performance is as stated, a minimum distance of twice the fan diameter is required between the appliance and any bends in the ductwork.

##### 3.1.1 Horizontal on Floor or Supported from Wall etc.

Optional resilient mountings should be attached to the unit mounting brackets at this stage.

If the unit is supported from a wall, supporting brackets should be used. Position and align the unit with the ductwork in both horizontal and vertical planes and pack height under mounting feet if necessary.

Attenuators, anti-back draught dampers form part of the fixed ductwork after the flexible connectors.

## 3.1.2 Suspended Horizontally or Vertically

A.V. mountings must be arranged so that they are used in **compression** only.

A suspended steel underframe would be necessary (by others) to support the unit, standing on A.V. mountings.

## 3.2 Electrical Installation

### 3.2.1 Motors

Motors are totally enclosed and protected to IP55 (Dust and low pressure water jets). Motors comply with BS5000, EN600034 and IEC34-1.

The motors have sealed for life ball bearings in units up to 132mm frame size. Frame sizes 160mm and above are re-greaseable type.

Enclosures are to IP55 with class H insulation. Motors are tested in accordance with EN12101-3.

N.B. Please note the requirements for maintenance of the motor. Failure to comply with the recommendations will invalidate any warranty claim.

### 3.2.2 Wiring

Electrical supply wiring connection is to an externally mounted terminal box on the case exterior. The box is pre-wired to the motor with heat resisting cable.

### 3.2.3 Connection details

Check that the voltage full load and starting current on the fan rating label is suitable for your supply.

Units for external use require weatherproof conduit and glands.

#### Single speed motors below 4kW

Single speed motors below 4kW are suitable for Direct On Line starting only.

#### Single speed motors 4kW and above

Single speed motors 4kW and above are supplied with Star / Delta capability but Direct On Line starting is recommended as the simplest means for emergency equipment operation.

#### Two speed motors

Two speed motors are supplied TAP or PAM single winding or Dual Wound. All two speed types are designed for Direct On Line starting on both speeds only unless otherwise specified.

## 3.3 Start Up Procedure

Ensure that the impeller rotation follows the label arrow indicator on the casing. Should the direction be incorrect on three phase units, reverse any two of the supply leads. Care should be taken to set correct rotation as incorrect rotation may result in damage to the motor. Equipment should be run for approx. 30 minutes to ensure correct operation.

If any fault occurs, the equipment should be switched off. Do not re-start until the fault has been rectified.

### IMPORTANT

**Isolation - Before commencing work, make sure that the unit, switched live and Nuaire controls are electrically isolated from the mains supply.**

## 4.0 SPECIFIC COMMISSIONING AND SERVICING REQUIREMENTS

300°C for 2 hours / 400°C for 2 hours Motors for Smoke Extract Fans

**Exposure temperature/time: 300°C for 2 hours / 400°C for 2 hours**

These motors are used to provide a SAFETY FUNCTION for people in the event of fire in public premises or in the home: they are therefore subject to strict constraints concerning their operating and maintenance.

### Operating Constraints

i. Check on the nameplate that the selected motor corresponds to the maximum exposure temperature and duration.

ii. Non ventilated motors MUST be placed in the airflow from the driven fan. Ventilating motors can be placed outside the flow.

iii. AFTER THE MOTOR HAS BEEN SUBJECTED TO ONE EMERGENCY DUTY OPERATION, IT MUST BE REPLACED.

iv. With variable speed control. Ensure that the maximum speed never exceeds the speed of the motor supplied by the mains and that the delivered power corresponds to the previous definitions. The motor should be equipped with PTC thermistors connected to the protection system during S1 duty and switched off during S2 duty (operation during an emergency).

These qualifications ensure the qualification of the driven fan by the manufacturer.

### Maintenance Constraints

**Regular service visits must be performed on the installation AT LEAST EVERY 6 MONTHS, incorporating the following checks:**

#### i. Checking the insulation resistance ( $R > 100$ MOhms, 500V DC)

- If the drain holes are blocked, open them to eliminate any accumulated condensation.
- If  $R < 100$  MOhms, dry the stator in an oven and check the insulation resistance. If the fault persists, replace the stator.
- The stator must be replaced 5 years after installation or after 20,000 hours of operation.

#### ii. Cooling check

- Ensure there is no dust or grease in the entire ventilation circuit (housing fins, motor cover/fan if fitted driven fan).
- Ensure the motor runs normally when switched on for a few minutes.

#### iii. Bearing check (C3 or C4 play)

Run the motor during each maintenance visit. When the motor is cold, a high level of noise is caused by the texture of the grease. This does not indicate a bearing fault.

#### S2 duty only:

The bearings must be replaced by an identical type every 5 years. Ensure the motor runs normally when switched on for a few minutes.

#### S1 duty and Emergency in S2 duty:

##### a) Permanently greased bearings.

300°C / 400°C range; replace on 2 pole motors after 10,000 hours of operation and on motors with 4 poles or more after 20,000 hours.

##### b) Re-greaseable bearings

The information on the motor nameplates must be strictly respected (grease quantity, grease quality and re-greasing frequency).

The bearings must be replaced after 20,000 hours of operation.

### 5.0 Wiring Diagrams

Single Speed, 3 phase

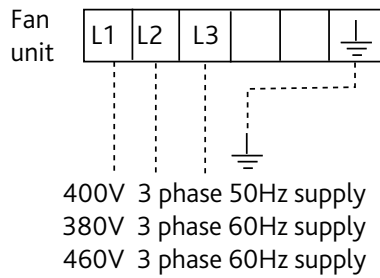

Two Speed - DUAL WOUND MOTOR  
D.O.L. Starting (Both Speeds), 3 phase

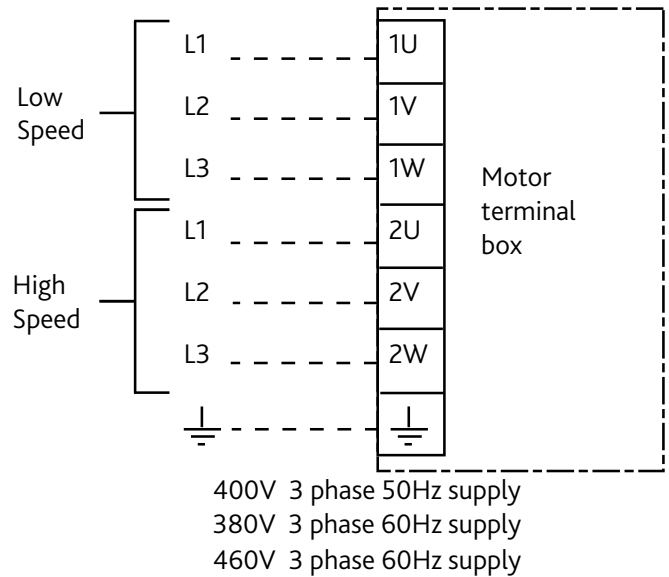

#### IMPORTANT

For specialist connections not shown always refer to the wiring diagram supplied with the unit. In the event of query or uncertainty contact NUAIRE directly before any connection is made.

D.O.L. Starting, 3 phase (3kW and below)

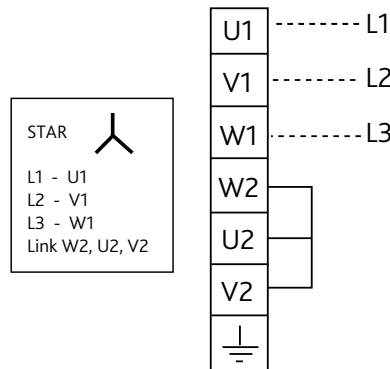

Star / Delta Starter, 3 phase (4kW and above)

Note:  
For all D.O.L. (Direct On Line) operation or Inverter type Speed Control wire in DELTA  $\Delta$

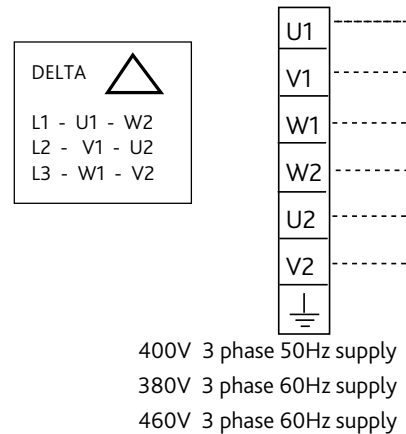

Speed Control - ELECTRONIC, 3 phase

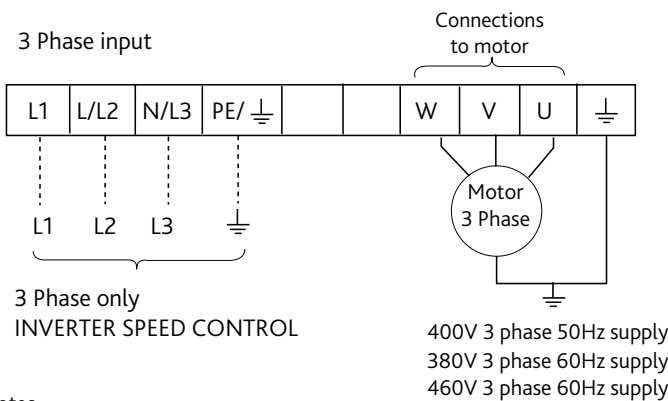

#### IMPORTANT

**Inverter control**  
Under fire conditions the electrical supply must not run through the inverter - The inverter must be bypassed.

Notes:

Total Length of motor leads should not exceed 50 metres. If a screened motor cable is used, maximum length should be 25 metres. Consult our Technical Department if you wish to use longer leads. Inverters are configured to suit specific fans and control applications as described on the Customer Order free of charge.

### 6.0 Maintenance

Nuair recommends all products maintained in accordance with the HVCA "Standard Maintenance Specification for Mechanical Services in Buildings" - Volume II Ventilating and Air Conditioning and BS5588 Pt. 12.

#### 6.1 Motor Maintenance

Induction motors, by their very nature require minimal maintenance. However, a regular regime of inspection is recommended to ensure minor problems do not escalate into breakdowns. Typical intervals would be 1000 hours of operation or 3 months, whichever is the sooner.

#### 6.2 Maintenance Check List ✓

No visible damage i.e. impeller cracked, fan cowl bent, foot cracked etc.

No accumulation of dust or fibres on the frame or around the fan inlet.

No significant corrosion of the lifting lugs/ eyebolts.

No excessive vibration.

No loose fasteners.

Cables and earths are sound.

Sealing of the motor and gland plate in good condition.

Insulation resistance adequate, imperative this is checked after prolonged shutdown.

Regreasing of bearings required, 160 frames and above.

Bearing condition.

#### Motor must be returned to manufacturer for repair.

Because the unit is certified to EN12101-3 and complying with the construction products directive, the motor must be returned to the motor manufacturer for replacement.

### 7.0 Warranty

The 3 year warranty starts from the day of delivery and includes parts and labour for the first year. The remaining 2 years covers replacement parts only.

This warranty is void if the equipment is modified without authorisation, is incorrectly applied, misused, disassembled, or not installed, commissioned and maintained in accordance with the details contained in this manual and general good practice.

The product warranty applies to the UK mainland and in accordance with Clause 14 of our Conditions of Sale. Customers purchasing from outside of the UK should contact Nuair International Sales office for further details.

### 8.0 After Sales Enquiries

Please contact Nuair Limited for information on any aspects of the motor performance that may need clarification. Contact must be made prior to any remedial action being taken under guarantee.

Please quote the motor serial number in all such cases with detailed description of the problem.

Telephone 02920 858 400  
aftersales@nuair.co.uk

Technical or commercial considerations may, from time to time, make it necessary to alter the design, performance and dimensions of equipment and the right is reserved to make such changes without prior notice.

## DECLARATION OF INCORPORATION AND INFORMATION FOR SAFE INSTALLATION, OPERATION AND MAINTENANCE

We declare that the machinery named below is intended to be assembled with other components to constitute a system of machinery. All parts except for moving parts requiring the correct installation of safety guards comply with the essential requirements of the Machinery Directive. The machinery shall not be put into service until the system has been declared to be in conformity with the provisions of the EC Machinery Directive.

Designation of machinery: AXUS AXIAL FLOW FAN  
 Machinery Types: AX  
 Relevant EC Council Directives: 2006/42/EC (Machinery Directive)  
 Applied Harmonised Standards: BS EN ISO 12100-1, BS EN ISO 12100-2, EN294, EN60204-1, BS EN ISO 9001  
 Applied National Standards: BS848 Parts One, Two and Five

### Signature of manufacture representatives:

Name:	Position:	Date:
1) C. Biggs 	Technical Director	20. 07. 07
2) A. Jones 	Manufacturing Director	20. 07. 07

Note: All standards used were current and valid at the date of signature.

## INFORMATION FOR SAFE INSTALLATION, OPERATION AND MAINTENANCE OF NUAIRE VENTILATION EQUIPMENT

To comply with EC Council Directives 2006/42/EC Machinery Directive and 2014/30/EU (EMC).  
 To be read in conjunction with the relevant product documentation (see 2.1)

### 1.0 GENERAL

1.1 The equipment referred to in this Declaration of Incorporation is supplied by Nuairé to be assembled into a ventilation system which may or may not include additional components. The entire system must be considered for safety purposes and it is the responsibility of the installer to ensure that all of the equipment is installed in compliance with the manufacturers recommendations and with due regard to current legislation and codes of practice.

### 2.0 INFORMATION SUPPLIED WITH THE EQUIPMENT

2.1 Each item of equipment is supplied with a set of documentation which provides the information required for the safe installation and maintenance of the equipment. This may be in the form of a Data sheet and/or Installation and Maintenance instruction. Each unit has a rating plate attached to its outer casing. The rating plate provides essential data relating to the equipment such as serial number, unit code and electrical data. Any further data that may be required will be found in the documentation. If any item is unclear or more information is required, contact Nuairé.

2.2 Where warning labels or notices are attached to the unit the instructions given must be adhered to.

### 3.0 TRANSPORTATION, HANDLING AND STORAGE

3.1 Care must be taken at all times to prevent damage to the equipment. Note that shock to the unit may result in the balance of the impeller being affected.

3.2 When handling the equipment, care should be taken with corners and edges and that the weight distribution within the unit is considered. Lifting gear such as slings or ropes must be arranged so as not to bear on the casing.

3.3 Equipment stored on site prior to installation should be protected from the weather and steps taken to prevent ingress of contaminants.

### 4.0 OPERATIONAL LIMITS

4.1 It is important that the specified operational limits for the equipment are adhered to e.g. operational air temperature, air borne contaminants and unit orientation.

4.2 Where installation accessories are supplied with the specified equipment eg. wall mounting brackets. They are to be used to support the equipment only. Other system components must have separate provision for support.

4.3 Flanges and connection spigots are provided for the purpose of joining to duct work systems. They must not be used to support the ductwork.

### 5.0 INSTALLATION REQUIREMENTS

In addition to the particular requirements given for the individual product, the following general requirements should be noted.

5.1 Where access to any part of equipment which moves, or can become electrically live are not prevented by the equipment panels or by fixed installation detail (e.g. ducting), then guarding to the appropriate standard must be fitted.

5.2 The electrical installation of the equipment must comply with the requirements of the relevant local electrical safety regulations.

5.3 For EMC all control and sensor cables should not be placed within 50mm or on the same metal cable tray as 230V switched live, lighting or power cables and any cables not intended for use with this product.

### 6.0 COMMISSIONING REQUIREMENTS

6.1 General pre-commissioning checks relevant to safe operation consist of the following: Ensure that no foreign bodies are present within the fan or casing. Check electrical safety. e.g. Insulation and earthing. Check guarding of system. Check operation of Isolators/Controls. Check fastenings for security. Other commissioning requirements are given in the relevant product documentation.

### 7.0 OPERATIONAL REQUIREMENTS

7.1 Equipment access panels must be in place at all times during operation of the unit, and must be secured with the original fastenings.

7.2 If failure of the equipment occurs or is suspected then it should be taken out of service until a competent person can effect repair or examination. (Note that certain ranges of equipment are designed to detect and compensate for fan failure).

### 8.0 MAINTENANCE REQUIREMENTS

8.1 Specific maintenance requirements are given in the relevant product documentation.

8.2 It is important that the correct tools are used for the various tasks required.

8.3 If the access panels are to be removed for any reason the electrical supply to the unit must be isolated.

8.4 A minimum period of two minutes should be allowed after electrical disconnection before access panels are removed. This will allow the impeller to come to rest.

**NB: Care should still be taken however since airflow generated at some other point in the system can cause the impeller to "windmill" even when power is not present.**

8.5 Care should be taken when removing and storing access panels in windy conditions.