

COMMISSIONING ECOSMART TWINFANS (EST-X/R/B) I phase, Direct Drive, Run & Standby for roof/external use

INDOOR USE ONLY

Introduction

This leaflet is intended to support the main Installation and Maintenance Instructions supplied with the fan unit. (Leaflet Number 671142) available on request from the Nuaire Technical Library. Telephone: 02920 885911.

Note: These units feature a commissioning box mounted on the case exterior for your convenience.

The main connections etc are located in the module inside the fan casing.

I. Getting started

The Ecosmart Twinfan is designed for maximum control flexibility. Apart from the power supply, an enabling signal is **always** required to set the fan running. This enabling signal can be a switched live signal (connected to the SL terminal of each fan) or an enabling device plugged in the NET connection (see table 'Ecosmart compatible devices').

If an enabling signal is not available, connect a link wire between 'L' & 'SL'.

Additional sensor and manual control may be added. For example: to run the fan with a temperature sensor, connect a link across L to SL (enabling signal) and connect a temperature sensor in one of the sockets labelled 'NET'

The fan will now adjust it's speed according to temperature.

To obtain manual control, connect a link across L to SL (enabling signal) and connect a user control in one of the sockets labelled 'NET'.

Ecosmart compatible devices

Enabling Devices

ES-PIR:	PIR Sensor
ES-TC:	7 day Timeclock

Sensors

ES-TEMP:	Temperature Sensor
ES-RH:	Humidity Sensor

User Controls

ES-UCF:	Fan only control
ES-UCFH:	Fan and Heating Control (heating will only operate within relevant units)

Others

ES-JB:	Junction Box (to add extra sensors etc)
ES-AVI:	Audio Visual Fault Indication

Note that these Ecosmart devices will affect all the fans linked using the SELV data cable.

The switched live signal will only affect the fan to which it is connected.

New devices are constantly in development, please contact us for latest range details.

Figure 1. Fan Control module connection details.

NOTE: Remove the link wire if a switched live signal is present or an enabling device or BMS is connected to the 'NET'

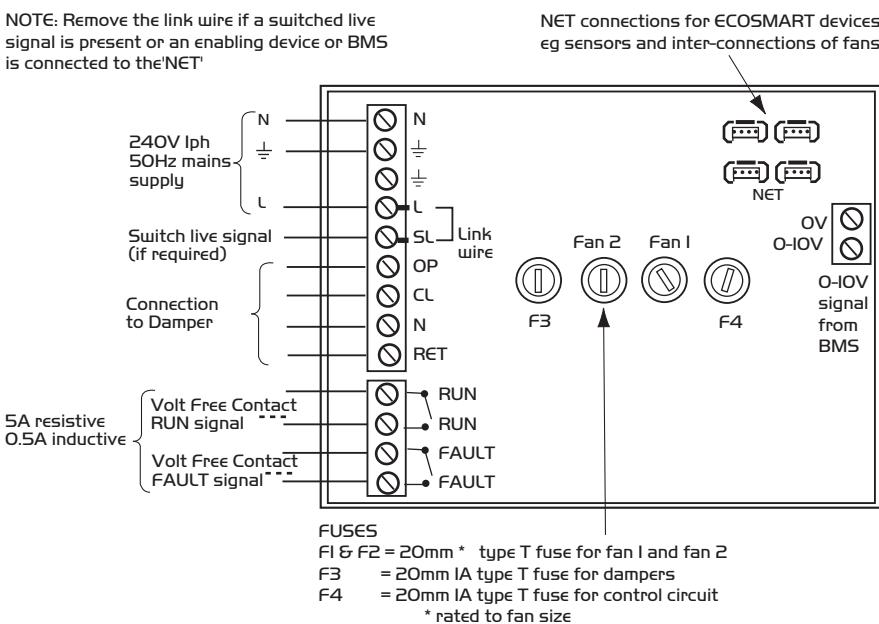
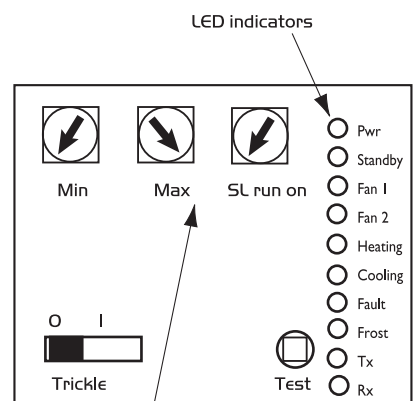

Figure 2. External Commissioning Box details.



- MIN = Minimum speed adjustment
- MAX = Maximum speed adjustment
- SL run on = Switched Live Run-On Timer adjustment
- TRICKLE = Selects trickle running:
O = off, I = selected
- TEST = Test button

2. BMS Signal

The systems response to a 0-10V dc BMS signal is given in the following table. Note the BMS signal will override any sensors and user control connected in the system.

The voltage tolerance is +/- 125mV and is measured at the fans terminal.

	Ventilation mode	Cooling mode*	Heating mode*
Local control	0.00	-	-
OFF/trickle	0.25	-	-
Speed 1	0.50	0.75	1.00
Speed 2	1.50	1.75	2.00
Speed 3	2.50	2.75	3.00
Speed 4	3.50	3.75	4.00
Speed 5	4.50	4.75	5.00
Speed 6	5.50	5.75	6.00
Speed 7	6.50	6.75	7.00
Speed 8	7.50	7.75	8.00
Speed 9	8.50	8.75	9.00
Speed 10	9.50	9.75	10.00

* Only available on relevant un

3. Commissioning Procedure

Setting the Maximum air flow

i) Ensure the power supply is switched off and that a link wire is connected from the supply L to the SL terminal. Unplug all items connected to the 'Net' connectors.

ii) Switch on the power supply whilst still maintaining access to the adjustment pots.

NOTE care must be taken as live parts are accessible.

iii) Wait for the fan to complete its self-test operation.

iv) Connect a manometer across the tapplings provided on the outside of the casing. Adjust the pot marked 'Max' to its maximum position. Read the manometer, transfer the pressure value to the relevant curve and read the volume flow. Mark the operating point on the curve and draw a parabolic system line between the origin and this operating point (point A on fig. 3). Adjust the 'Max' pot so that the pressure reading corresponds with the required airflow (point B of fig. 3).

Setting the Minimum/trickle airflow (nominally 40%)

i) Repeat the same procedure as for maximum airflow above but without the link wire between supply L and SL terminal. Ensure the trickle switch is in the 'ON' position.

The adjustment must be made on the pot marked 'Min'

ii) Note that the minimum setting (nominally 40%) must be below the maximum setting, otherwise minimum setting will be automatically set to be the same as the maximum.

After setting the airflows, reconnect all the items disconnected previously.

Ensure that the cover over the mains terminals is replaced and that the cover of the controls enclosure is securely fastened.

3. Using the graphs

The graphs are designed to assist in the establishment of the desired air volume flow rate for the installation.

After the fan is installed in the ventilation system and connected to the power supply, connect a manometer across the pressure tapplings on the outside of the fan casing. Note that negative pressure is present at the fan inlet and positive at the fan outlet; the combined value is required.

Set the fan to run at maximum speed as per commissioning procedure and take the pressure reading (in Pa) across the fan. Use the relevant graph for the fan, plot the pressure point and read the volume flowrate.

For example; if the pressure is 100Pa, draw a horizontal line from 100Pa until it touches the curve (see fig. 3 point A). Drop the line vertically down to give the volume flow of the fan. If it is necessary to adjust the flowrate, draw a parabolic system line between the origin and the operating point. Alternatively draw a straight line; this should give a reasonable estimate in most installations. Draw a straight line from the required airflow (point C) up to meet the system line (point B) and read the corresponding pressure value (point D). Adjust the pot so that the manometer gives the same pressure reading as point D to obtain the required airflow.

Note that the typical minimum volume achievable with this fan range is approximately 40%.

Figure 3. Typical EST graph (size 1 unit shown).

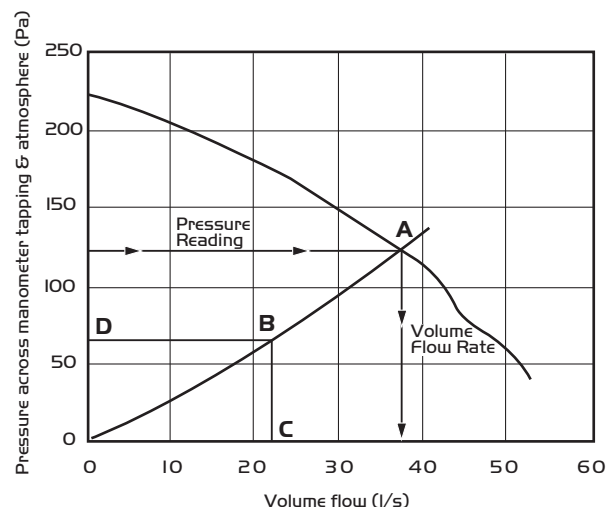

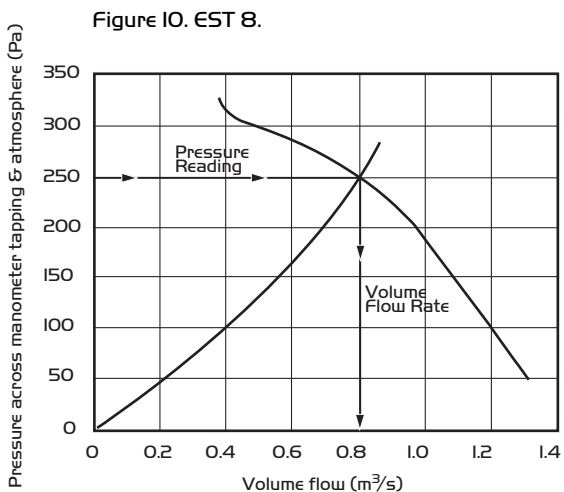
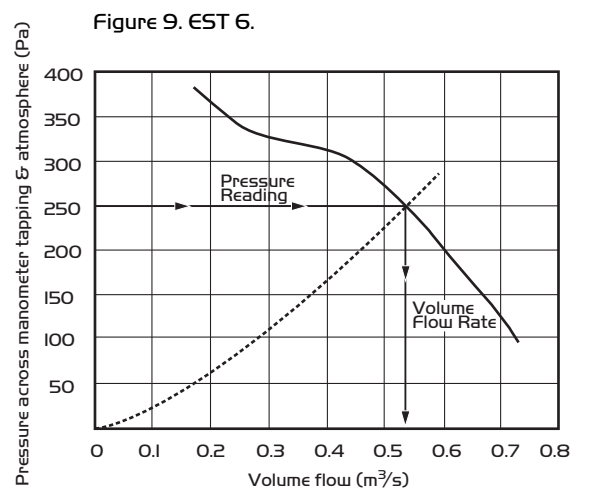
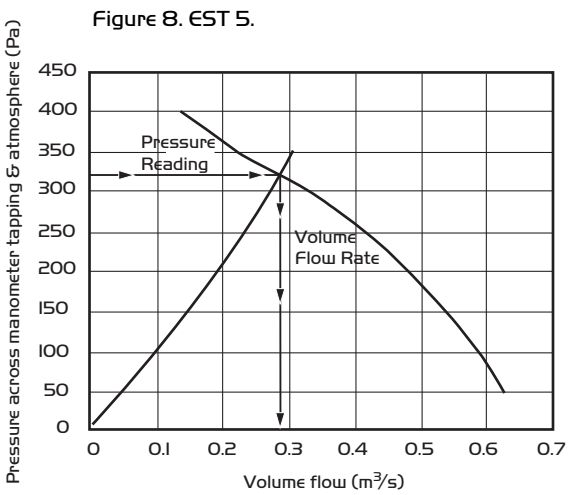
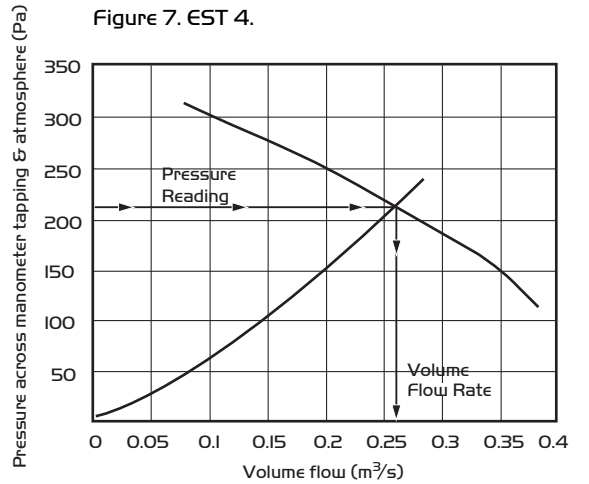
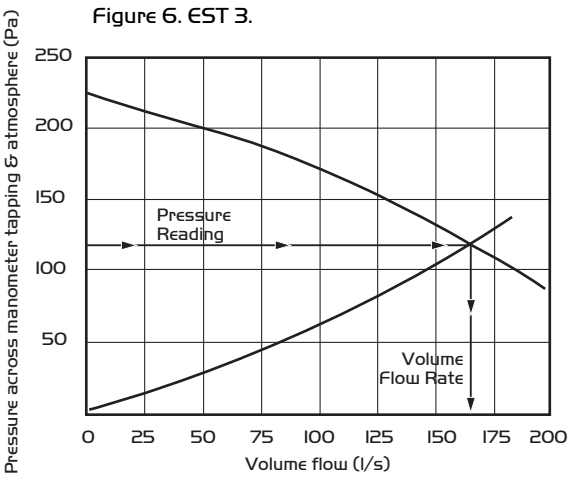
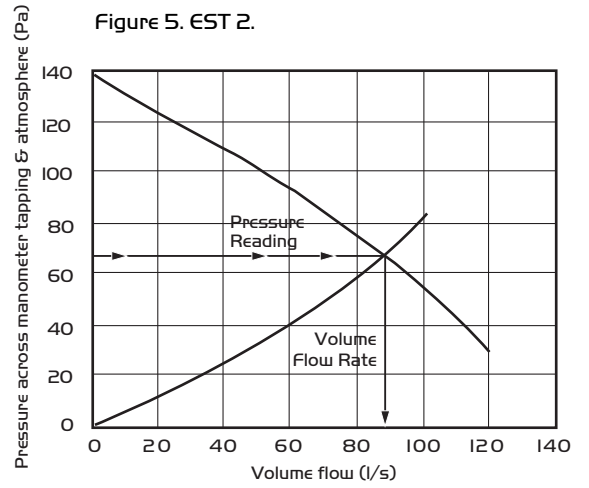
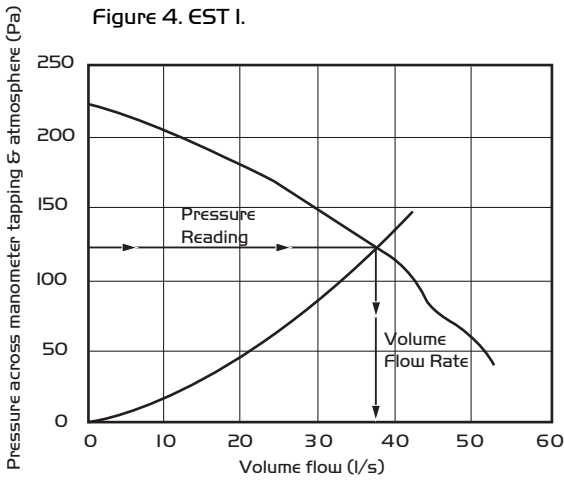

Commissioning Graphs

To be used in conjunction with the commissioning procedure as detailed on page 2.