

# FLAT2000L/R

## Low Energy Positive Input Ventilation Unit Installation and Maintenance



### 1.0 INTRODUCTION

The Nuair Drimaster/Flatmaster range has been curing severe condensation problems for over 20 years in some of the worst affected properties throughout the world. Its successful operation depends entirely upon the unit being installed strictly in accordance with these instructions. We would, therefore, respectfully suggest that you read through this guide in its entirety before commencing installation and then go through this guide step by step to ensure a satisfactory completion.

Units are supplied assembled and include a thermostatically controlled heater. A unit mounted override switch is provided. A 'BOOST' speed facility for additional ventilation is included. This is operated by a remote switch (supplied).

The FLAT2000 L/R is a 'handed' product, with the L/R signifying the discharge direction, as viewed from the front. The FLAT2000L unit is supplied arranged for LEFT HAND discharge of air. The FLAT2000R unit is supplied arranged for RIGHT HAND discharge of air.

#### IMPORTANT

Whilst the installation of the Flatmaster unit may be achieved by a suitable craftsman, the provision of the electrical supply and the connection of the unit to the mains must be carried out by a qualified electrician.

### 2.0 INSTALLATION

#### IMPORTANT

Where the systems are installed in flats, ensure all regulatory provisions are adhered to. Where the systems are installed in flats where these regulatory provisions do not apply, good installation practice should be observed.

For more information please refer to the Building Regulations, Approved Document B (Fire safety) – Volume 1: Dwelling houses (2006 Edition)

The unit is designed to take fresh air from outside, clean the air, and discharge it into the central hallway via a system of ducting supplied by the installer.

The dwelling supply grille is usually installed at high level in a central location within the hallway, although discharging the air down the length of the hallway (away from the front door) should also prove acceptable. Unit performance may be enhanced if an existing heat source can warm the discharged air e.g. by locating the discharge grille above a radiator.

Before commencing installation decide the best position for the unit and where the fresh air is to come from and be discharged to. The unit can be installed in many different configurations and is supplied with enough interchangeable spigots to enable it to be used with either round (100mm) or rectangular ducting (121mm x 60mm).

Figure 1. Typical installation of a right handed unit with top discharge (FLAT2000R).

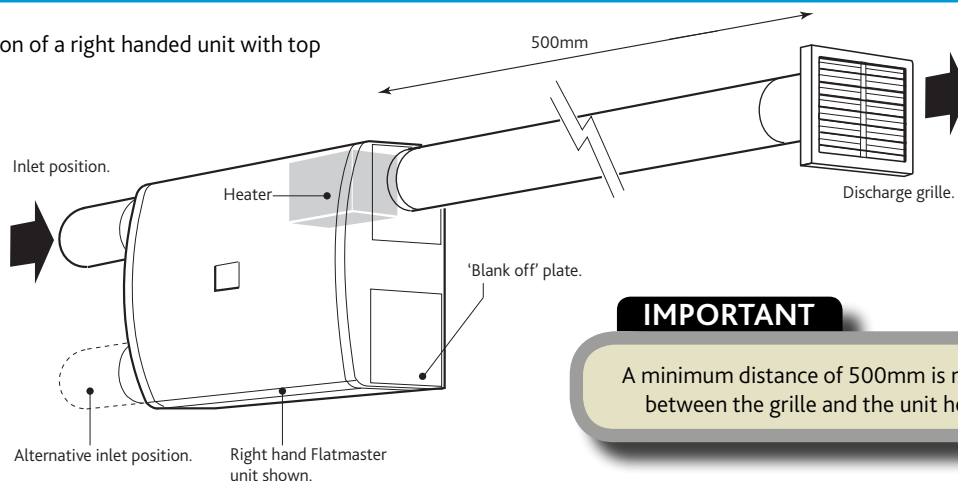

#### IMPORTANT

A minimum distance of 500mm is required between the grille and the unit heater.

#### IMPORTANT

The heater outlet MUST NOT be left exposed, a minimum duct length of 500mm is required between the unit heater and discharge grille.

### 2.1 Spigot inserts

The unit is designed to be used with rigid ducting only. Ensure that when the ducting is fitted it is secured in place using wall brackets and screws on the duct as close to the spigots as possible to prevent the spigot inserts (fig 1) or rigid ducting from being removed or accidentally knocked off. If it is necessary to fit flexible ducting then the spigot inserts should be glued in place, using super glue Loctite 454 Gel, at the clip points 1, 2, 3 & 4 for all spigot inserts (see fig. 2).

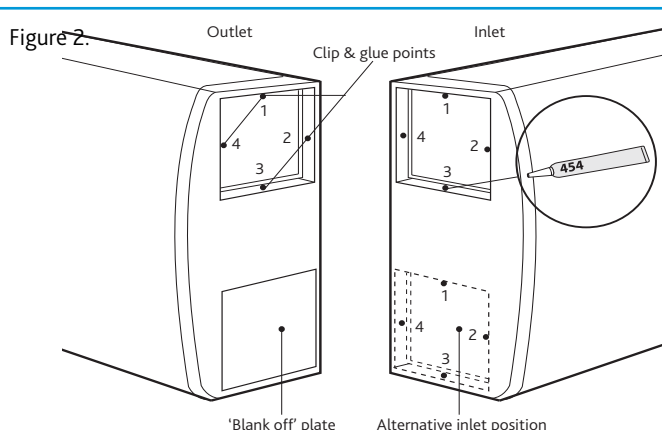

### 2.2 Fixing the unit to the wall

The unit has three mounting feet. Mark through these feet when the unit is in the correct position. Drill and plug wall with suitable fixings. Remove PCB cover and feed the electrical supply cable through the grommet hole (standard 1mm three core lighting cable is recommended) in the rear of the unit screw unit to wall (see fig. 3).

**Installers must ensure the grommet provided or other suitable insulated grommet/bushing is used for cable entry.**

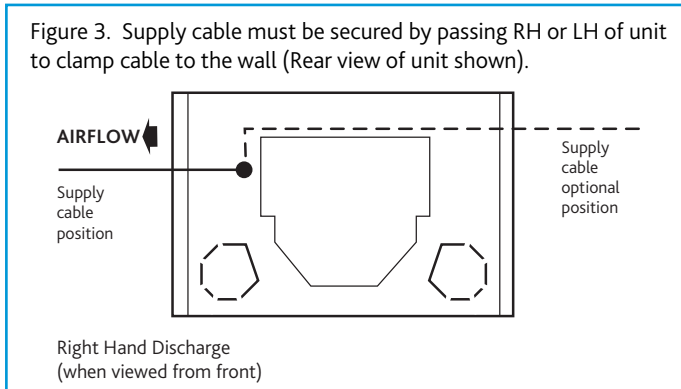

#### Points to consider

- The inlet ducting should be kept as short as possible to avoid condensation build up on the ducting surface (see fig. 5 and 6).
- Find the shortest, most direct route from outside of the unit and then to the discharge grille using the least number of bends (these bends increase the airflow resistance).
- Note the location of any joists, pipes, electrical cables etc.
- Allow adequate access to the front cover to allow filter cleaning.

### 2.3 Fitting of ducts

To prevent access to live or moving parts ensure ducts are adequately secured to the spigots by fitting self tapping screws or by other means requiring a tool. If using duct tape ensure tape cannot be removed without the use of a tool by securing with tie wraps.

### 2.4 Inlet/Outlet grille installation

If a fly screen is fitted it should be removed from both the internal and external grille.

NOTE: When installing the internal grille, the louvres **must slant upwards** to ensure the correct air circulation and the avoidance of unpleasant down draughts.

The outside wall input grille louvres **must slant downwards**.

Standard 100mm dia ducting or 121 x 60mm ducting is used to connect the Flatmaster to the input and discharge grilles.

#### Fixing all necessary ducting

A full range of ductwork and ductwork ancillaries are available. Please contact Nuaire for further details.

### IMPORTANT

Any air intake terminal **MUST** be installed in accordance with the appropriate regulation.

As a guide, the BS5440 series of British Standards deals with this issue and currently states that an air intake must be at a minimum distance of 300mm from a gas boiler balanced flue. Installers are advised to be aware of the requirements of this standard when installing 'through the wall' supply air ducting. Similarly, supply and extract air grilles should be at least 300mm apart.

Figure 4. Side input installation.

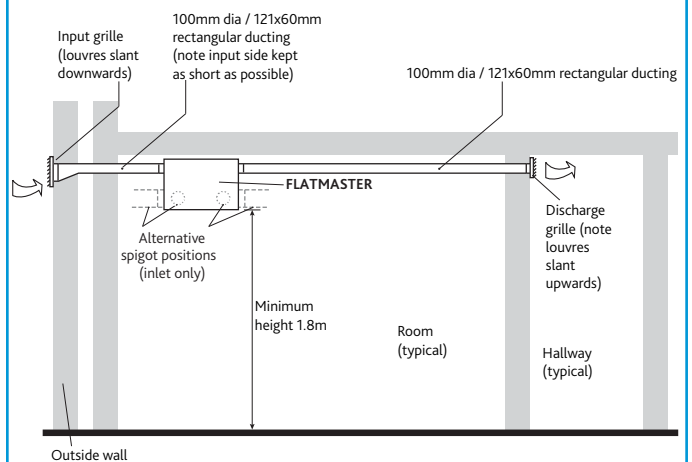
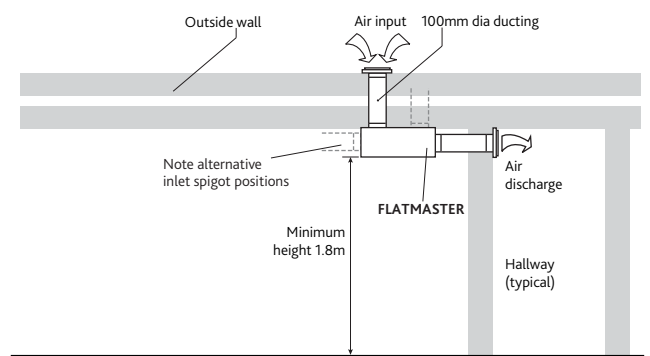

Figure 5. Rear input installation (view from above).



### IMPORTANT

The internal grille **must not** be placed within 1.5m of a smoke alarm.

### 3.0 DIMENSIONS(mm)

Dimensions for the space required can be determined from the dimensions shown in figure 10 below.

Allow an additional 32mm for the length of each end spigot and any additional room for installation and maintenance e.g. access to screws on top and bottom of unit for front cover.

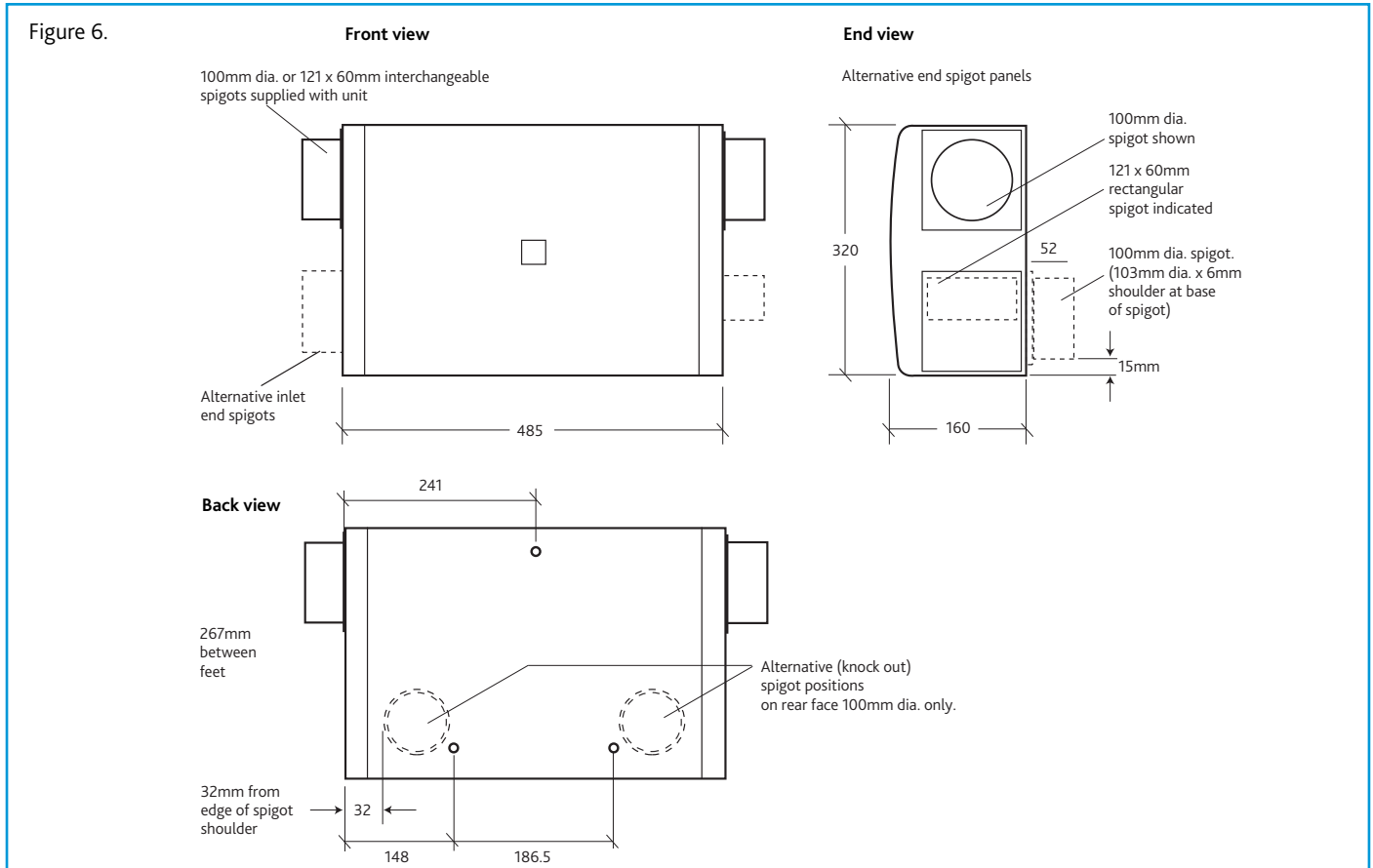

### 4.0 ELECTRICAL DETAILS

Supply - 230V 1 phase 50Hz

It is necessary to allow all pole disconnection of the appliance from the supply by incorporating a switch in the fixed wiring in accordance with current IEE wiring regulations.

#### Electrical connection

Please note the electrical connections to the unit should be carried out by a qualified electrician. With the PCB cover removed (see figure 4) pull the PCB forward to gain access to earth post behind. Connect Earth cable to Earth post next to the grommet hole.

Slide PCB into slot and connect the mains supply L and N to the terminal block. Ensure the supply cable does not come into contact with the PCB transformer by tie wrapping to the slots in the PCB enclosure. Ensure that a 3 amp fused spur is fitted on the supply.

### 4.1 Wiring Details

Figure 7. Customer installation wiring. Adjustments can now be made via the access holes without removing the PCB cover. Use a small screwdriver to move the slide switches.

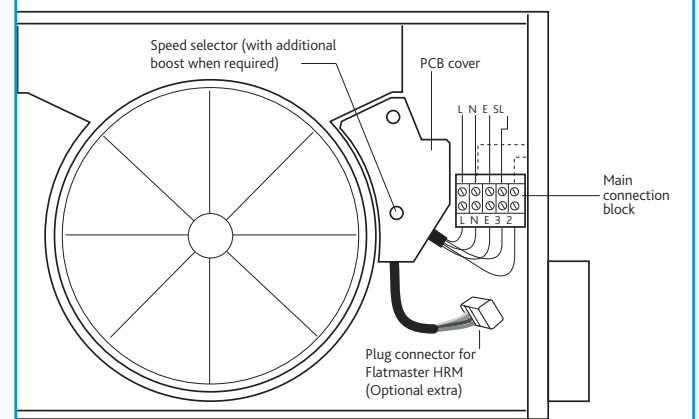

#### IMPORTANT

For good EMC engineering practice, any sensor cables or switched live cables should not be placed within 50mm of other cables or on the same metal cable tray as other cables.

#### IMPORTANT

Warning: Ensure that the fan is isolated from the mains supply before removing cover.

### 4.2 Remote Switch

Figure 8. Wiring the remote switch

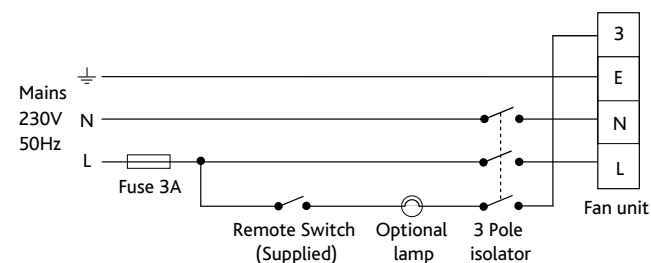

### 4.3 Smoke alarm automatic shut down

If the unit is required to switch off in the event of smoke detection, alarms are available with separate relay bases from companies such as:

**Dicon Safety products** – [www.diconsafety.co.uk](http://www.diconsafety.co.uk)

**Aico Ltd** – [www.aico.co.uk](http://www.aico.co.uk)

Figure 9. Typical wiring (refer to manufactures specific instructions).

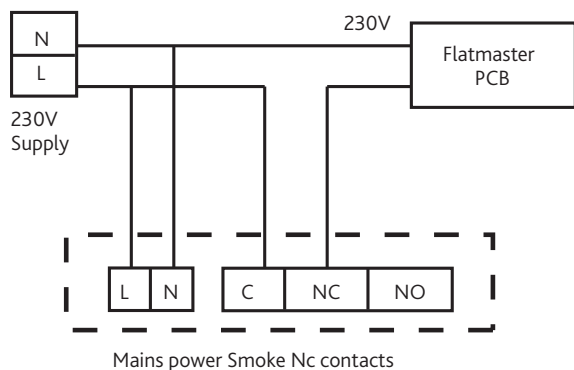

### 5.0 SETTING THE UNIT

The speed selector is located on the PCB (see figure 12). The unit has a choice of three speeds to suit the size of the dwelling and the moisture being generated. The unit is factory set at No 3-High Speed. We recommend that the unit is operated at this speed and the setting reduced if and when necessary in the future.

### 6.0 MAINTENANCE

The maintenance requirements for this product can be found in the "Product Safety – Essential Operational Checks" section, which is located in this document and includes the replacement of the filter (Our part number FLAT-FILTERKIT) every 12 months; this interval may need to be shortened, if the unit is operating under adverse environmental conditions.

### 7.0 WARRANTY

The unit has a 5 year warranty starting from the day of delivery and includes parts and labour for the first year. The remaining 4 years covers parts only. This warranty is conditional on the following:-

- That the unit is installed strictly in accordance with this guide.
- That the unit filters are removed and replaced at the recommended intervals.

This warranty is void if the equipment is modified without authorisation, is incorrectly applied, misused, disassembled, or not installed, commissioned and maintained in accordance with the details contained in this manual and general good practice.

The product warranty applies to the UK mainland and in accordance with Clause 14 of our Conditions of Sale. Customers purchasing from outside of the UK should contact Nuair International Sales office for further details.

### 8.0 AFTER SALES

For technical assistance or further product information, including spare parts and replacement components, please contact the After Sales Department.

**Telephone 02920 858 400**  
[aftersales@nuaire.co.uk](mailto:aftersales@nuaire.co.uk)

# Installation and Maintenance

FLAT2000L/R Low Energy Positive Input Ventilation Unit

## Product Safety - Essential Operational Checks

Project Address

Date Of Check

Unit Code

Unit Serial Number

No action required  
 Remedial action required  
 Make safe and corrective action required

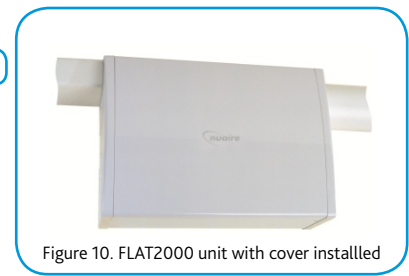

## Product Condition

### DATE OF LAST MAINTENANCE

Within last 12 months   
  12-24 months ago   
  More than 24 months ago   
  Unknown

### GENERAL CONDITION

General condition   
  Ductwork intact   
  Casing damaged   
  Ductwork damaged

### GENERAL CLEANLINESS EXTERNAL

Clean   
  Light contamination   
  Heavy contamination

### GENERAL CLEANLINESS INTERNAL

Clean   
  Light contamination   
  Heavy contamination

### CONDITION OF FANS

Operational   
  Clean   
  Light contamination   
  Heavy contamination   
  Non-operational

### CONDITION OF FILTERS

Clean   
  Light contamination   
  Missing   
  Heavy Contamination   
  Damaged/perforated

### CONDITION OF HEATER

Operational   
  All components present   
  Discoloured   
  Distorted   
  Non-operational or incomplete

## Installation

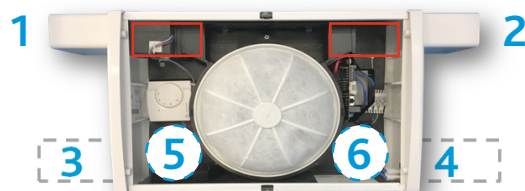

Figure 11. Schematic of spigot configurations (RED shows heater position)

Indicate Inlet Position (3, 4, 5 or 6)

Indicate Supply Outlet Position

Approx length of ductwork on inlet (600mm min.)

Approx length of ductwork on supply outlet (600mm min.)

Height of unit above floor level (1.8m min)

Fused spur fitted? (Y/N)

Fused rating fitted (Amp)