

# Installation Guide

## *smart controls*

# Humidity Sensor

For  
**SmartSqrbo**  
and  
**SmartBoxer**  
systems

**NUAIRE**

NuAire Limited,  
Western Industrial Estate,  
Caerphilly, Mid Glamorgan,  
CF83 1XH, United Kingdom.  
Tel: 01222 885911 Fax: 01222 887033  
Email: info@nuaire.co.uk

Leaflet 670823

MAY 1999

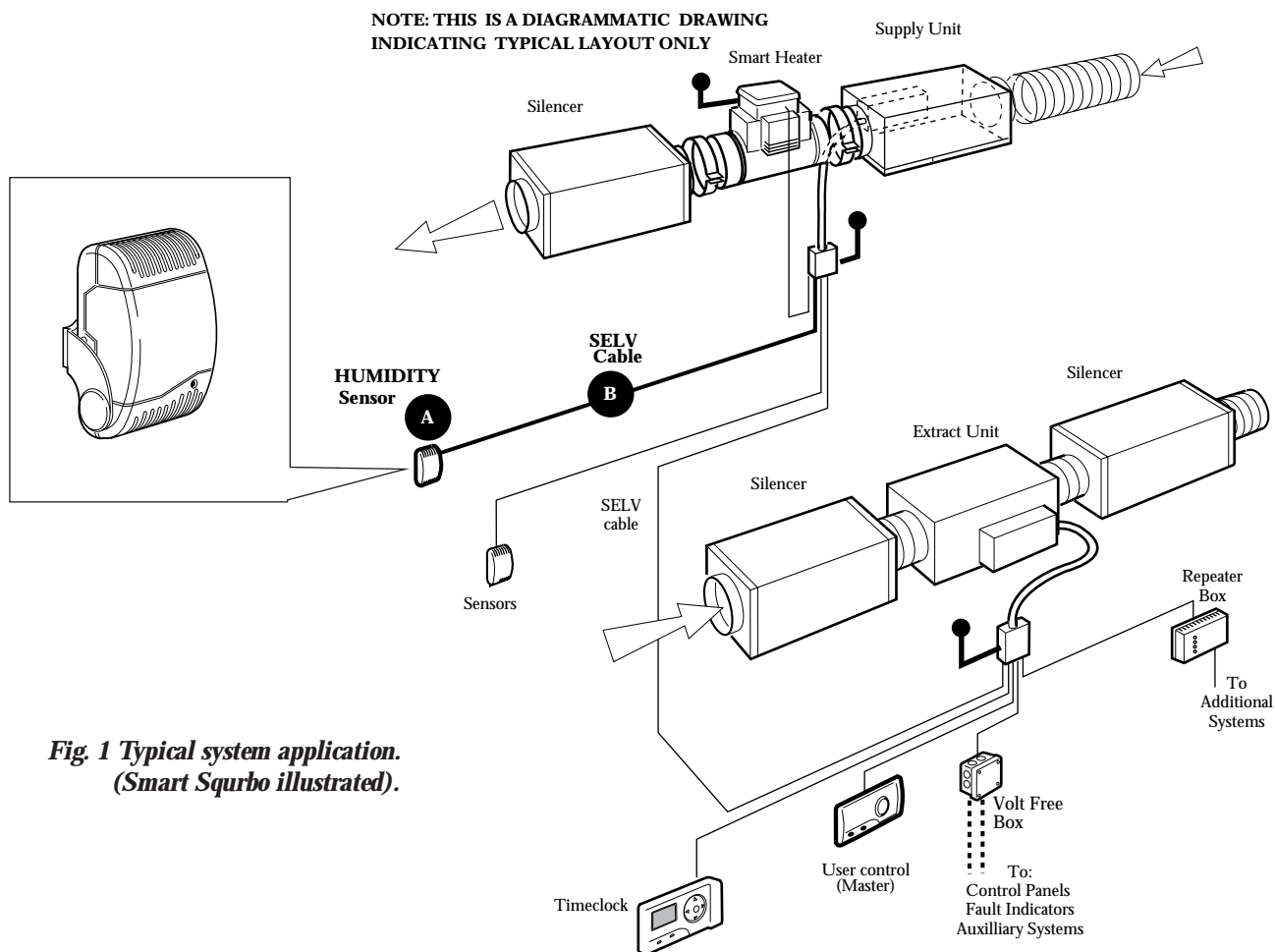

**Fig. 1 Typical system application.**  
(Smart Sqrbo illustrated).

### Parts check list

- A** SS-HUM-LV Humidity Sensor
- B** 1 off 10 metre length of plugged SELV cable

### SS-HUM-LV Humidity Sensor

Designed to be used with the Smart Sqrbo and Smart Boxer range of supply and extract fans the sensor is supplied with a pre-plugged 10m length of communications cable.

The sensor operates on Safe Extra Low Voltage and is powered from the fan control module

This Sensor will vary the ventilation rate automatically according to the measured humidity.

The sensor has an adjustable 50-100% RH set point

### Communications cable

A 10m length of Safe Extra Low Voltage communications cable (SELV) is supplied with the sensor.

## Sensors

### Low Voltage Sensor (SS-HUM-LV)

#### Installing the Sensor

The Sensor is supplied complete with 10 metres of connecting cable with plugs attached. Sensors are also supplied with all fixings and are clipped into a backplate wall mounting bracket.

- Fix one end of the 10m cable to the fans customer connection box (connection sockets marked NET).
- Select a suitable location for the sensor and arrange the cable in position. Leave approx. 75mm of the cable free at the mounting point to ease the connection of the plug. (fig. 2).
- Carefully separate the sensor from the backplate using a small screwdriver (see Fig 3) Note: the sensor will remain connected by its internal cable.
- Release this cable from the bracket by simply pulling the plug off the socket pins in the backplate.
- Before fixing the backplate to the wall, connect the wall fixed cable end plug to the UPPER set of pins on the bracket (fig 4) NOTE: CHECK THE COLOUR CODE matching on when fitting the plug onto the pins. Arrange the cable to lay in the cable slot at the top of the backplate moulding and fix the bracket to the wall surface using the screws supplied.
- The sensor plug can now be connected into the backplate NOTE: CHECK THE COLOUR CODE matching when fitting the plug onto the pins. Clip the sensor body in the backplate arms and adjust the sensor body to the desired position.

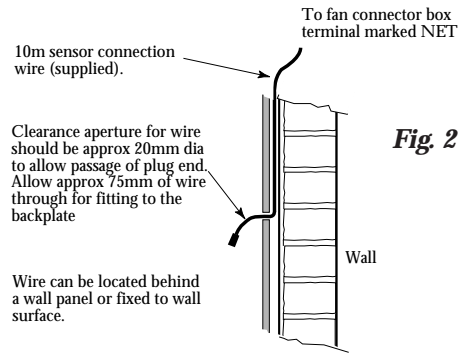

Fig 2

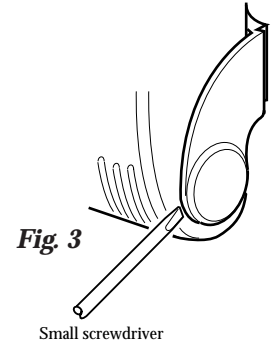

Fig 3

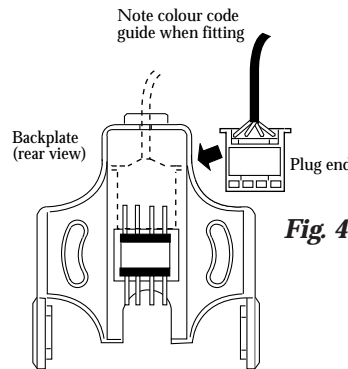

Fig 4

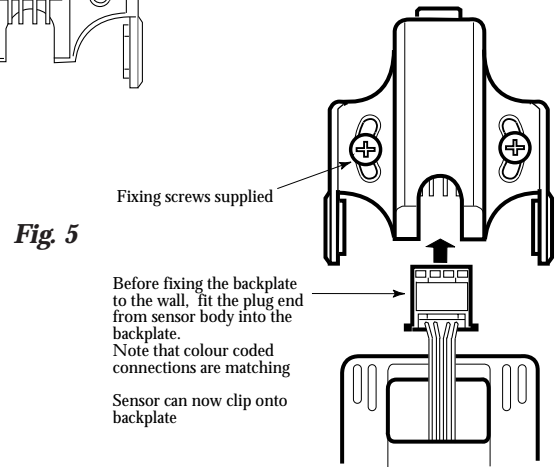

Fig 5

#### Using the 'trickle setting'

At stage (d) above, take the sensor body and carefully prise the two halves apart using a small screwdriver or similar tool. Locate the four miniature slide switches in the corner of the circuit board and position slider 3 to the ON position to activate the trickle setting.

#### Adjusting the sensor set points

SS-HUM-LV Set Point: **Adjustable RH setting 50-100% RH**

Assuming the sensor(s) are installed, adjustment of the set point is achieved by tilting the sensor forwards which exposes the adjustment aperture (see fig 7). Using a small screwdriver, gently turn the dial either clockwise or anti-clockwise to increase or decrease the set point.

When adjustments are made to the sensor, the LED light on the sensor front will illuminate RED for approx 2 seconds. The light will then extinguish for approx 1 second and begin to blink an AMBER colour. The number of blinks indicate the setting i.e. one blink on a SS-HUM-LV would inform you that the sensor has been set an extra 5% to 55%

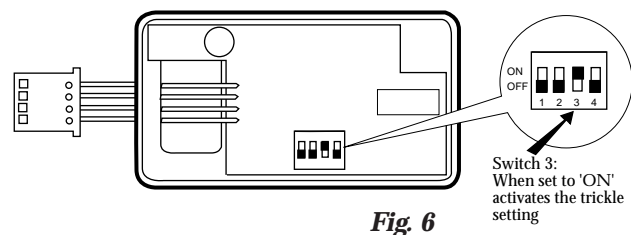

Fig 6

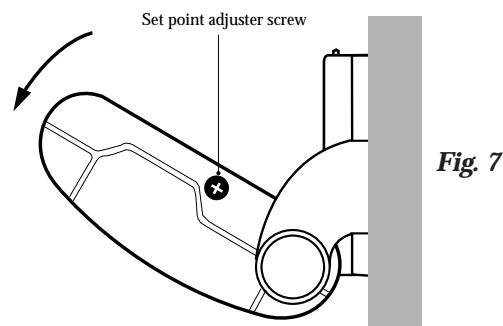

Fig 7

## CE DECLARATION OF CONFORMITY

OCTOBER 1998



*We declare that the equipment named below  
conforms to the requirements of EC Council Directive  
relating to Electromagnetic Compatibility*

---

<b>Designation of equipment :-</b>	SMART CONTROLS (SENSOR)
<b>Equipment Types :-</b>	SS-HUM-LV
<b>Relevant EC Council Directives :-</b>	89/336/EEC, 92/31/EEC (EMC) 73/23/EEC, 93/68/EEC (Low Voltage Directive)
<b>Applied Harmonised Standards :-</b>	E50081-1, EN50082-1, EN60204-1
<b>Basis of Self Attestation :-</b>	Quality Assurance to BS EN ISO 9001 BSI Registered Firm Certificate No. FM 149

---

**Signature of manufacture representatives :-**

	<b>Name:</b>	<b>Position:</b>	<b>Date:</b>
1)	 C. Biggs	Technical Director	2. 10. 98
2)	 Michael J. Fussell	Manufacturing Director	2. 10. 98

## Controls Application Service (CAS)

A team of Engineers and technicians is available to provide pre and post order support.

We are on hand to provide help and advice from the most basic use of any NuAire equipment to the more complex applications, maximising on the versatility of our SMART and NetLink control products.

**Telephone: 01222 858585**

**Facsimile: 01222 858586**

## Service

As a manufacturer NuAire can provide you with factory trained Service Engineers.

Our Engineers are supported by a comprehensive range of spare parts 'off the shelf'.

If you are an industrial or commercial user, you may be interested in details of NuAire's regular maintenance Service Contracts. This is a worthwhile service that helps you get the most from our products.

Our Service Department will be happy to give you more information.

Please telephone: **01222 858271**

*Technical or commercial considerations may, from time to time, make it necessary to alter the design, performance and dimensions of equipment and the right is reserved to make such changes without prior notice.*

# **NUAIRE**

**Western Industrial Estate,  
Caerphilly, Mid Glam CF83 1XH  
United Kingdom.**

**Telephone: 01222 885911**

**Facsimile: 01222 887033,**

**Email: [info@nuaire.co.uk](mailto:info@nuaire.co.uk)**

Leaflet No. 670823